

# 產品尺寸圖 (DIMENSION)

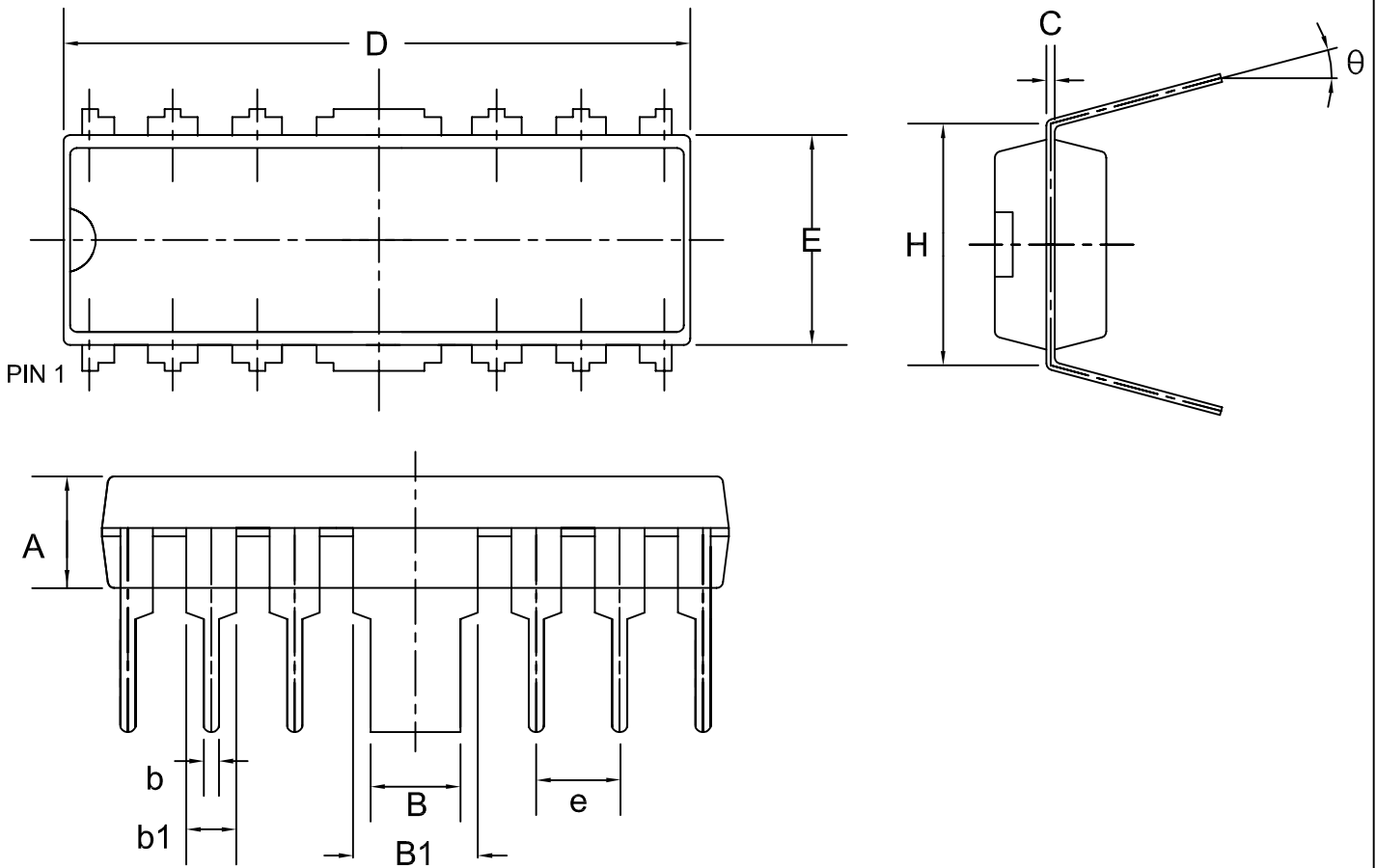

Symbol	Dimensions In Millimeters			Dimensions In Inches		
	Min	Nom	Max	Min	Nom	Max
A	3.15	3.40	3.65	0.124	0.134	0.144
B	—	3.00	—	—	0.118	—
B1	—	4.06	—	—	0.160	—
b	—	0.46	—	—	0.018	—
b1	—	1.52	—	—	0.060	—
C	—	0.25	—	—	0.010	—
D	18.90	19.00	19.10	0.744	0.748	0.752
E	6.20	6.30	6.40	0.244	0.248	0.252
H	7.37	7.62	7.87	0.290	0.300	0.310
e	—	2.54	—	—	0.100	—
$\theta$	0°	—	15°	0°	—	15°

Note: QC. Inspection Range : A.D.E

<b>PACKAGE</b>	DIP-12H	
<b>DRAWING NUMBER</b>	DIM-DIP12H-0103-B	
<b>SIGNATURE</b>	<b>ORG.</b>	蘇育正
	<b>APPR.</b>	康哲郡