

產品尺寸圖 (DIMENSION)

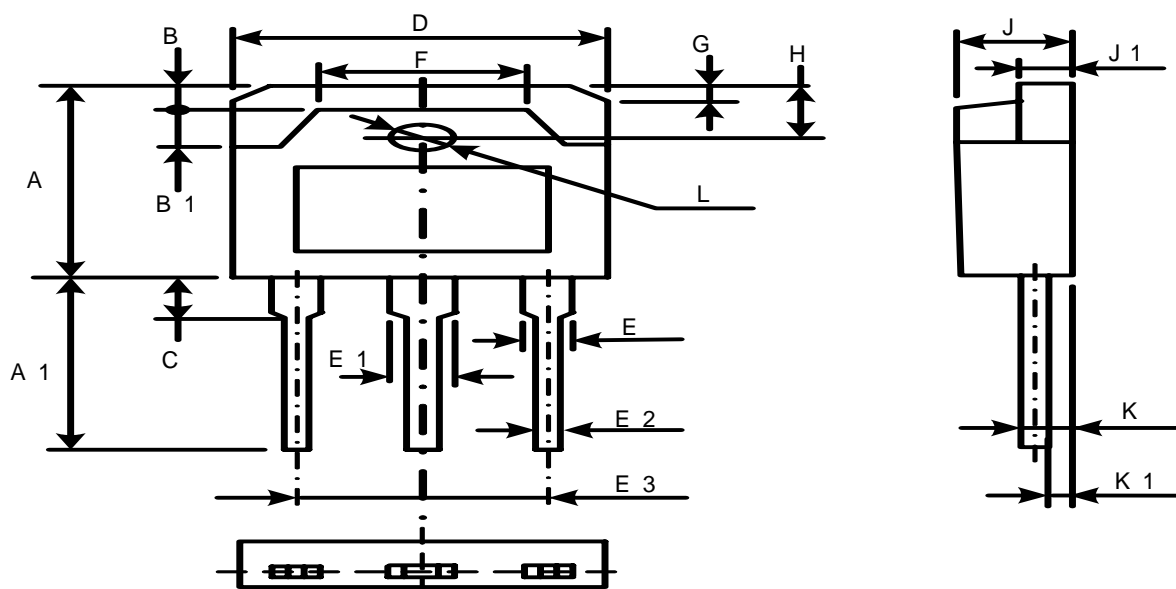

DIM	Dimensions In Millimeters (mm)			Dimensions in Inches (Inch)		
	MIN.	TYP.	MAX.	MIN.	TYP.	MAX.
A	19.6	19.9	20.2	4.978	5.055	5.131
A1	19.5	20	20.5	4.953	5.080	5.207
B	1.9	2	1.9	0.483	0.508	0.483
B1	3.9	4	4.1	0.991	1.016	1.041
C	3.9	4	4.1	0.991	1.016	1.041
D	15.2	15.6	16	3.861	3.962	4.064
E	1.9	2	2.1	0.483	0.508	0.533
E1	2.9	3	3.1	0.737	0.762	0.787
E2	0.95	1.05	1.25	0.241	0.267	0.318
E3	5.35	5.45	5.55	1.359	1.384	1.410
F	9.5	9.6	9.7	2.413	2.438	2.464
G	1.7	1.8	1.9	0.432	0.457	0.483
H	4.8	5.0	5.2	1.219	1.270	1.321
L	3.1	3.2	3.3	0.787	0.813	0.838
J	4.6	4.8	5.0	1.168	1.219	1.270
J1	1.4	1.6	1.8	0.356	0.406	0.457
K	0.55	0.65	0.85	0.140	0.165	0.216
K1	1.3	1.4	1.5	0.330	0.356	0.381

Note : QC. Inspection Range : A,B,C,D,E,G

PACKAGE	TO-3PN	
DRAWING NUMBER	DIM- TO3PN -0606-A	
SIGNATURE	製圖	葉政宏
	審核	葉政宏
	核准	張乃舜