



2SB649/A

PNP SILICON TRANSISTOR

BIPOLAR POWER GENERAL PURPOSE TRANSISTOR

■ APPLICATIONS

* Low frequency power amplifier complementary pair with UTC 2SB669/A

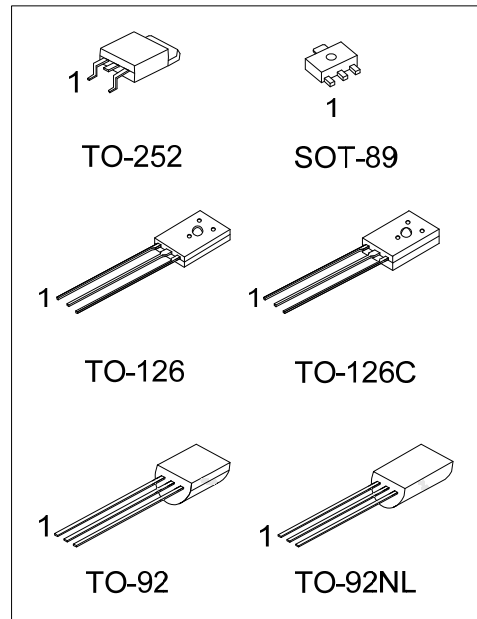

Lead-free: 2SB649L/2SB649AL
Halogen-free: 2SB649G/2SB649AG

■ ORDERING INFORMATION

Order Number			Package	Pin Assignment			Packing
Normal	Lead Free Plating	Halogen Free		1	2	3	
2SB649-x-AB3-R	2SB649L-x-AB3-R	2SB649G-x-AB3-R	SOT-89	B	C	E	Tape Reel
2SB649-x-T6C-K	2SB649L-x-T6C-K	2SB649G-x-T6C-K	TO-126C	E	C	B	Bulk
2SB649-x-T60-K	2SB649L-x-T60-K	2SB649G-x-T60-K	TO-126	E	C	B	Bulk
2SB649-x-T92-B	2SB649L-x-T92-B	2SB649G-x-T92-B	TO-92	E	C	B	Tape Box
2SB649-x-T92-K	2SB649L-x-T92-K	2SB649G-x-T92-K	TO-92	E	C	B	Bulk
2SB649-x-T9N-B	2SB649L-x-T9N-B	2SB649G-x-T9N-B	TO-92NL	E	C	B	Tape Box
2SB649-x-T9N-K	2SB649L-x-T9N-K	2SB649G-x-T9N-K	TO-92NL	E	C	B	Bulk
2SB649-x-TN3-R	2SB649L-x-TN3-R	2SB649G-x-TN3-R	TO-252	B	C	E	Tape Reel
2SB649A-x-AB3-R	2SB649AL-x-AB3-R	2SB649AG-x-AB3-R	SOT-89	B	C	E	Tape Reel
2SB649A-x-T6C-K	2SB649AL-x-T6C-K	2SB649AG-x-T6C-K	TO-126C	E	C	B	Bulk
2SB649A-x-T60-K	2SB649AL-x-T60-K	2SB649AG-x-T60-K	TO-126	E	C	B	Bulk
2SB649A-x-T92-B	2SB649AL-x-T92-B	2SB649AG-x-T92-B	TO-92	E	C	B	Tape Box
2SB649A-x-T92-K	2SB649AL-x-T92-K	2SB649AG-x-T92-K	TO-92	E	C	B	Bulk
2SB649A-x-T9N-B	2SB649AL-x-T9N-B	2SB649AG-x-T9N-B	TO-92NL	E	C	B	Tape Box
2SB649A-x-T9N-K	2SB649AL-x-T9N-K	2SB649AG-x-T9N-K	TO-92NL	E	C	B	Bulk
2SB649A-x-TN3-R	2SB649AL-x-TN3-R	2SB649AG-x-TN3-R	TO-252	B	C	E	Tape Reel

<p>2SB649L-x-AB3-R</p> <p>(1)Packing Type (2)Package Type (3)Rank (4)Lead Plating</p>	<p>(1) B: Tape Box, K: Bulk, R: Tape Reel (2) AB3: SOT-89, T6C: TO-126C, T60: TO-126, T92: TO-92, T9N: TO-92NL, TN3: TO-252 (3) x: refer to Classification of h_{FE} (4) G: Halogen Free, L: Lead Free, Blank: Pb/Sn</p>
---	---

■ ABSOLUTE MAXIMUM RATINGS (Ta=25°C, unless otherwise specified)

PARAMETER		SYMBOL	RATING	UNIT
Collector-Base Voltage		V _{CBO}	-180	V
Collector-Emitter Voltage	2SB649	V _{CEO}	-120	V
	2SB649A		-160	V
Emitter-Base Voltage		V _{EBO}	-5	V
Collector Current		I _C	-1.5	A
Collector Peak Current		I _{C(PEAK)}	-3	A
Collector Power Dissipation	TO-126/TO-126C	P _C	1.4	W
	TO-92/TO-92NL		1	W
	SOT-89		0.5	W
	TO-252		2	W
Junction Temperature		T _J	+150	°C
Storage Temperature		T _{STG}	-40 ~ +150	°C

Note: Absolute maximum ratings are those values beyond which the device could be permanently damaged.
 Absolute maximum ratings are stress ratings only and functional device operation is not implied.

■ ELECTRICAL CHARACTERISTICS (Ta=25°C, unless otherwise specified)

PARAMETER		SYMBOL	TEST CONDITIONS	MIN	TYP	MAX	UNIT
Collector to Base Breakdown Voltage		BV _{CBO}	I _C =-1mA, I _E =0	-180			V
Collector to Emitter Breakdown Voltage	2SB649	BV _{CEO}	I _C =-10mA, R _{BE} =∞	-120			V
	2SB649A			-160			
Emitter to Base Breakdown Voltage		BV _{EBO}	I _E =-1mA, I _C =0	-5			V
Collector Cut-off Current		I _{CBO}	V _{CB} =-160V, I _E =0			-10	μA
DC Current Gain	2SB649	h _{FE1}	V _{CE} =-5V, I _C =-150mA (note)	60		320	
		h _{FE2}	V _{CE} =-5V, I _C =-500mA (note)	30			
	2SB649A	h _{FE1}	V _{CE} =-5V, I _C =-150mA (note)	60		200	
		h _{FE2}	V _{CE} =-5V, I _C =-500mA (note)	30			
Collector-Emitter Saturation Voltage		V _{CE(SAT)}	I _C =-600mA, I _B =-50mA			-1	V
Base-Emitter Voltage		V _{BE}	V _{CE} =-5V, I _C =-150mA			-1.5	V
Current Gain Bandwidth Product		f _T	V _{CE} =-5V, I _C =-150mA		140		MHz
Output Capacitance		C _{ob}	V _{CB} =-10V, I _E =0, f=1MHz		27		pF

Note: Pulse test.

■ CLASSIFICATION OF h_{FE1}

RANGE	RANK		
	B	C	D
2SB649	60-120	100-200	160-320
2SB649A	60-120	100-200	-

TYPICAL CHARACTERISTICS

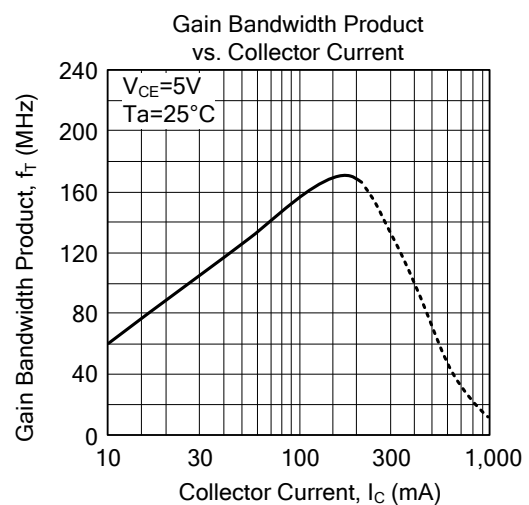
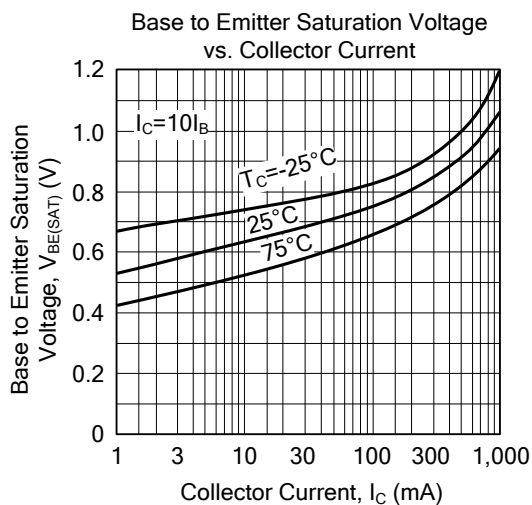
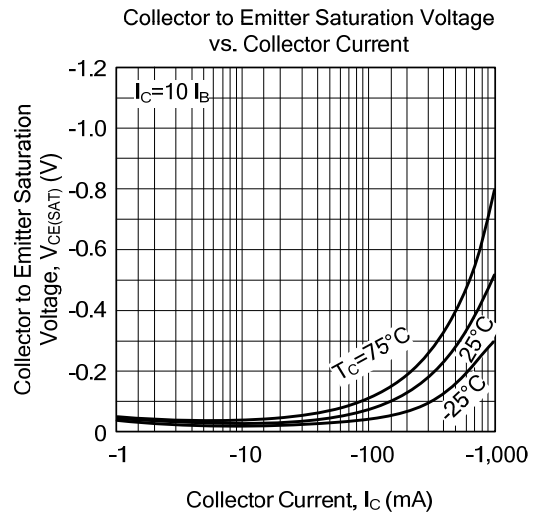
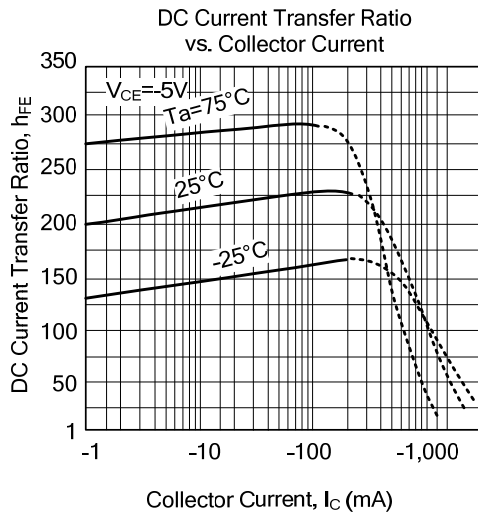
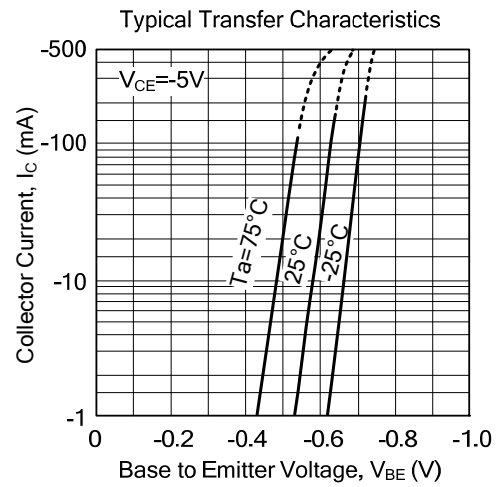
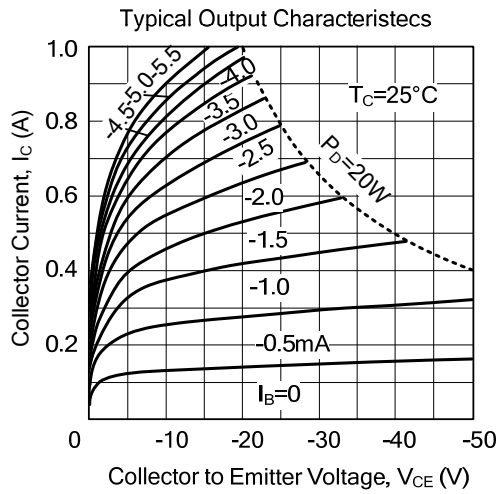

■ TYPICAL CHARACTERISTICS(Cont.)

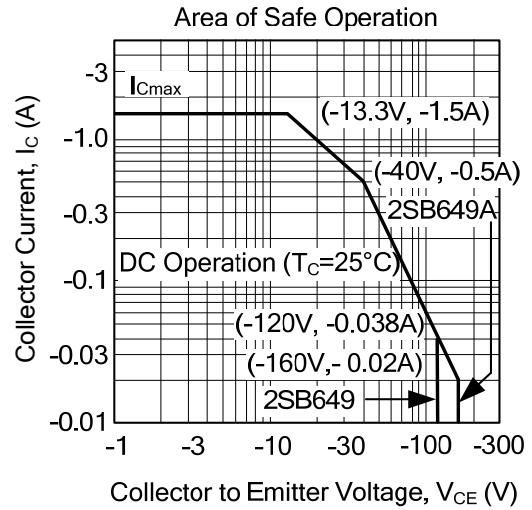
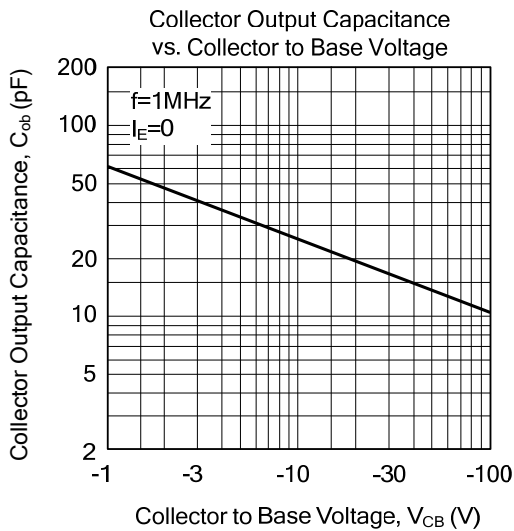

UTC assumes no responsibility for equipment failures that result from using products at values that exceed, even momentarily, rated values (such as maximum ratings, operating condition ranges, or other parameters) listed in products specifications of any and all UTC products described or contained herein. UTC products are not designed for use in life support appliances, devices or systems where malfunction of these products can be reasonably expected to result in personal injury. Reproduction in whole or in part is prohibited without the prior written consent of the copyright owner. The information presented in this document does not form part of any quotation or contract, is believed to be accurate and reliable and may be changed without notice.