



## 2SB834

## PNP SILICON TRANSISTOR

### HIGH VOLTAGE TRANSISTOR

#### DESCRIPTION

Low frequency power amplifier applications.

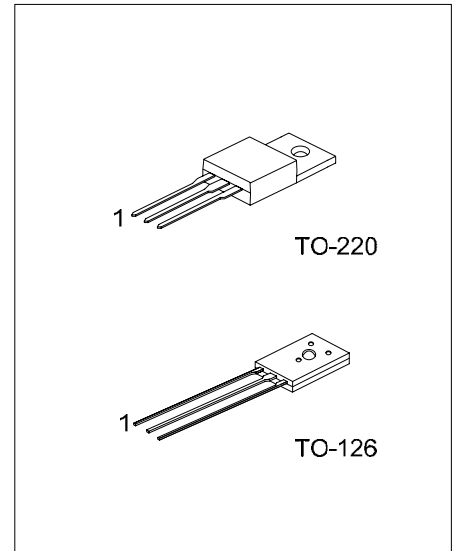

\*Pb-free plating product number: 2SB834L

#### ORDERING INFORMATION

Ordering Number		Package	Pin Assignment			Packing
Normal	Lead Free Plating		1	2	3	
2SB834-x-T60-K	2SB834L-x-T60-K	TO-126	E	C	B	Bulk
2SB834-x-TA3-T	2SB834L-x-TA3-T	TO-220	B	C	E	Tube

<p>2SB834L-x-T60-K</p> <p>(1)Packing Type (2)Package Type (3)Rank (4)Lead Plating</p>	<p>(1) K: Bulk, T: Tube (2) T60: TO-126, TA3: TO-220 (3) x: refer to Classification of <math>h_{FE1}</math> (4) L: Lead Free Plating, Blank: Pb/Sn</p>
---	--

■ ABSOLUTE MAXIMUM RATINGS (Operating temperature range applies unless otherwise specified )

PARAMETER	SYMBOL	RATINGS	UNIT
Collector-Base Voltage	$V_{CBO}$	60	V
Collector-Emitter Voltage	$V_{CEO}$	60	V
Emitter-Base Voltage	$V_{EBO}$	7	V
Collector Current	$I_C$	3	A
Base Current	$I_B$	0.5	A
Total Power Dissipation ( $T_C=25$ )	TO-126	25	W
	TO-220	30	W
Junction Temperature	$T_J$	+125	
Storage Temperature	$T_{STG}$	-40 ~ +150	

Note: Absolute maximum ratings are those values beyond which the device could be permanently damaged.

Absolute maximum ratings are stress ratings only and functional device operation is not implied.

■ ELECTRICAL CHARACTERISTICS ( $T_a=25$  , unless otherwise specified)

PARAMETER	SYMBOL	TEST CONDITIONS	MIN	TYP	MAX	UNIT
Collector-Emitter Breakdown Voltage	$BV_{CEO}$	$I_C=50mA$	60			V
Collector Cut-Off Current	$I_{CBO}$	$V_{CB}=60V$			100	$\mu A$
Emitter Cut-Off Current	$I_{EBO}$	$V_{EB}=7V$			100	$\mu A$
Collector-Emitter Saturation Voltage	$V_{CE(SAT)}$	$I_C=3A, I_B=0.3A$			1	V
Base-Emitter On Voltage	$V_{BE(ON)}$	$V_{CE}=5V, I_C=0.5A$		0.7	1	V
DC Current Gain	$h_{FE1}$	$I_C=0.5A, V_{CE}=5V$	60		300	
	$h_{FE2}$	$I_C=3A, V_{CE}=5V$	20			
Current Gain Bandwidth Product	$f_T$	$V_{CE}=5V, I_C=0.5A$		9		MHZ

■ CLASSIFICATION of  $h_{FE1}$

RANK	O	Y	GR
RANGE	60-120	100-200	150-300

## TYPICAL CHARACTERISTICS

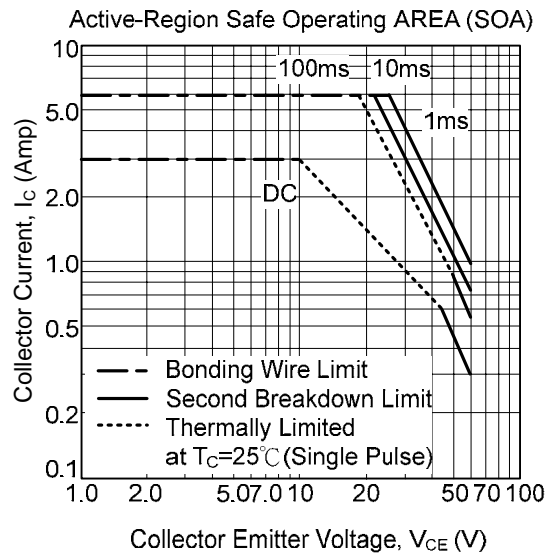
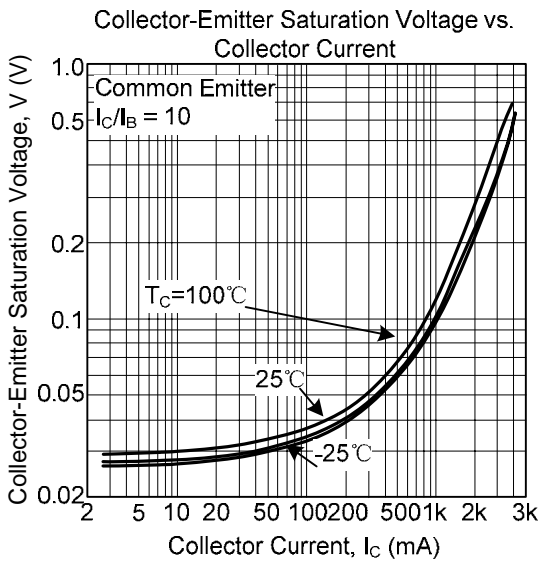
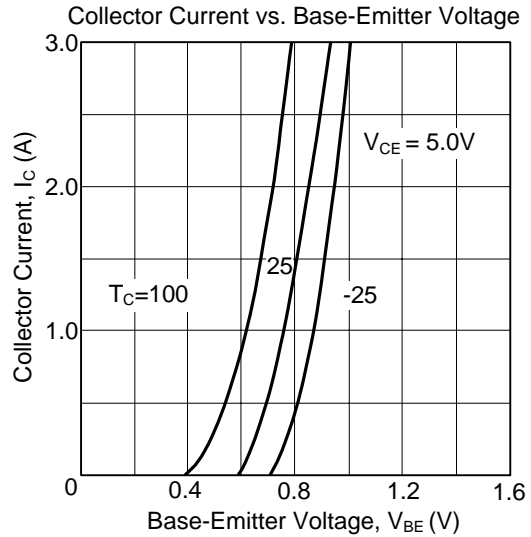
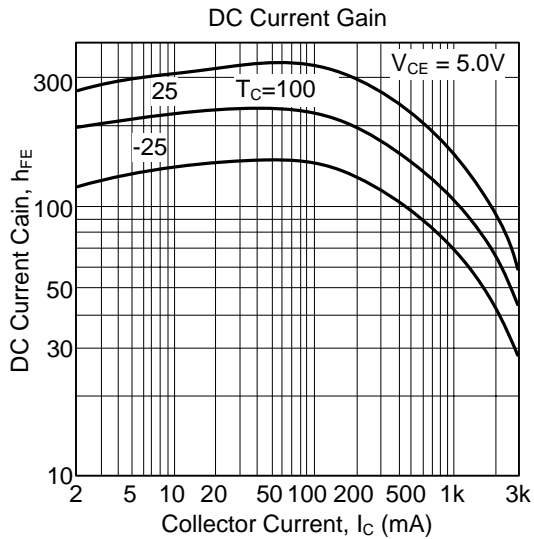
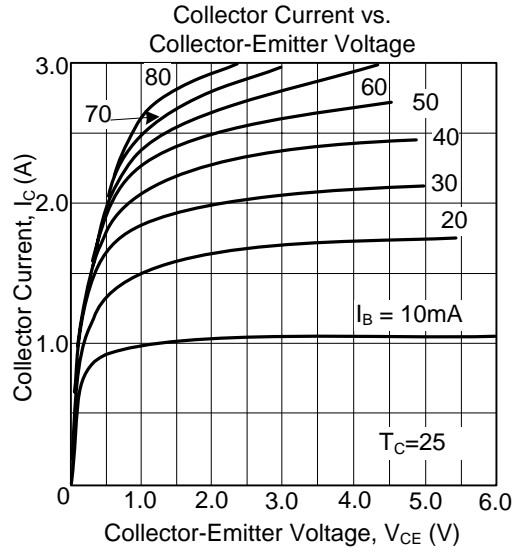
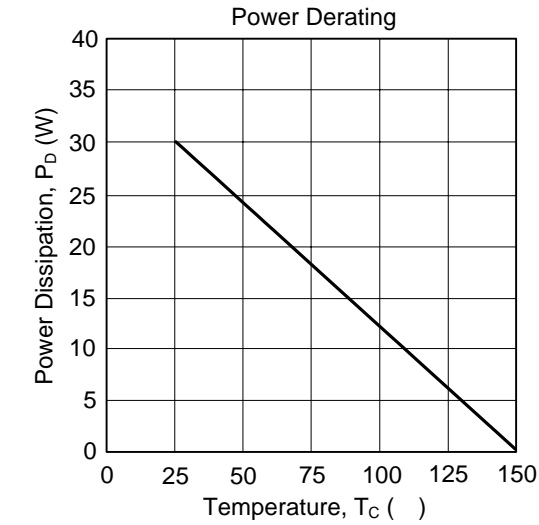

UTC assumes no responsibility for equipment failures that result from using products at values that exceed, even momentarily, rated values (such as maximum ratings, operating condition ranges, or other parameters) listed in products specifications of any and all UTC products described or contained herein. UTC products are not designed for use in life support appliances, devices or systems where malfunction of these products can be reasonably expected to result in personal injury. Reproduction in whole or in part is prohibited without the prior written consent of the copyright owner. The information presented in this document does not form part of any quotation or contract, is believed to be accurate and reliable and may be changed without notice.