



62783

Preliminary

LINEAR INTEGRATED CIRCUIT

8CH HIGH-VOLTAGE SOURCE DRIVER

DESCRIPTION

The UTC 62783 consists of eight source current transistor array combination and it is suitable for fluorescent display applications.

The UTC 62783 is ideal for uses, such as relay, hammer and lamp drivers.

FEATURES

- *High output voltage: $V_{CC} = 50V$ (MIN.)
- * Output current (single output) $I_{OUT} = -500mA$ (MIN.)
- * Output clamp diodes and single supply voltage
- * Input compatible with various types of logic
- * TTL, 5V CMOS
- * Halogen Free

ORDERING INFORMATION

Ordering Number		Package	Packing
Lead Free Plating	Halogen Free		
62783L-D18-T	62783G-D18-T	DIP-8	Tube
62783L-S18-R	62783G-S18-R	SOP-18	Tape Reel

<p>62783L-D18-R</p> <p>(1) Packing Type (2) Package Type (3) Lead Plating</p>	<p>(1) R: Tape Reel, T: Tube (2) D18: DIP-18, S18: SOP-18 (3) G: Halogen Free, L: Lead Free</p>
---	---

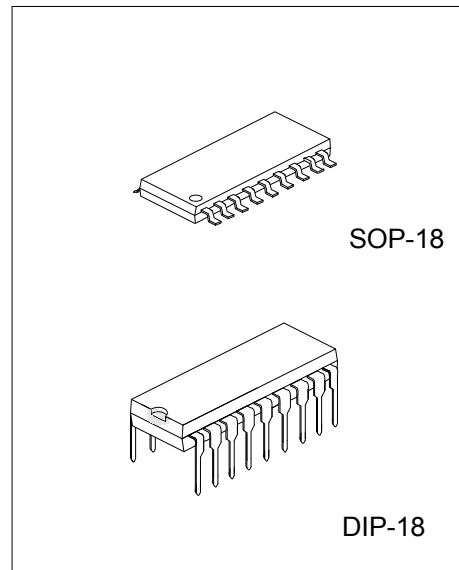

■ PIN CONFIGURATION

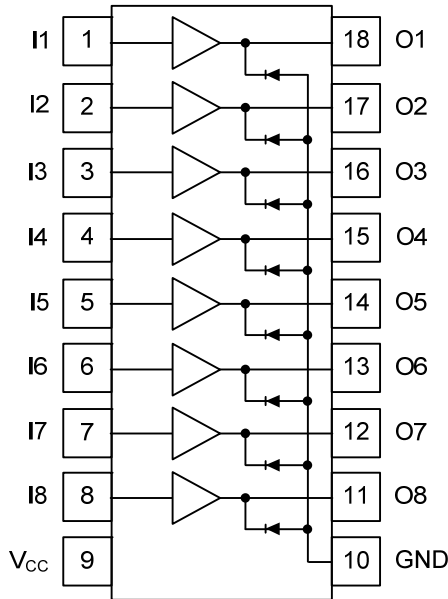

■ SCHEMATICS(EACH DRIVER)

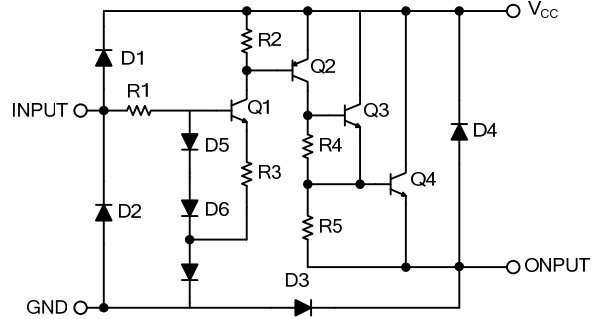

R1	R2	R3	R4	R5
10kΩ	20kΩ	2.6kΩ	10kΩ	5kΩ

Note: The input and output parasitic diodes cannot be used as clamp diodes

■ PIN DESCRIPTION

PIN NO.	PIN NAME	DESCRIPTION
1	I1	Input Of CH1
2	I2	Input Of CH2
3	I3	Input Of CH3
4	I4	Input Of CH4
5	I5	Input Of CH5
6	I6	Input Of CH6
7	I7	Input Of CH7
8	I8	Input Of CH8
9	V _{CC}	Power Supply
10	GND	Ground
11	O8	Output Of CH8
12	O7	Output Of CH7
13	O6	Output Of CH6
14	O5	Output Of CH5
15	O4	Output Of CH4
16	O3	Output Of CH3
17	O2	Output Of CH2
18	O1	Output Of CH1

■ ABSOLUTE MAXIMUM RATING (Ta = 25°C)

PARAMETER	SYMBOL	RATINGS	UNIT
Supply Voltage	V _{CC}	50	V
Input Voltage	V _{IN}	15	V
Clamp Diode Reverse Voltage	V _R	50	V
Output Current	I _{OUT}	-500	mA/ch
Clamp Diode Forward Current	I _F	500	mA
Power Dissipation	DIP-18	P _D	mW
	SOP-18		
Derated Above 25°C			
Operating Temperature	T _{OPR}	-40~+85	°C
Storage Temperature	T _{STG}	-55~+150	°C

Note: Absolute maximum ratings are those values beyond which the device could be permanently damaged. Absolute maximum ratings are stress ratings only and functional device operation is not implied.

■ RECOMMENDED OPERATING CONDITIONS (Ta = -40 ~ +80°C)

PARAMETER	SYMBOL	TEST CONDITIONS	MIN	TYP	MAX	UNIT	
Supply Voltage	V _{CC}				50	V	
Output Current	I _{OUT}	Ta=85°C, T _J =120°C, T _p =25ms			Duty=10%	-180	mA/ch
					Duty=50%	-38	mA/ch
Input Voltage	V _{IN}				12	V	
Input Voltage	Output On	V _{IN(ON)}	2.0	5.0	15	V	
	Output Off	V _{IN(OFF)}	0		0.8	V	
Clamp Diode Reverse Voltage	V _R				35	V	
Clamp Diode Forward Current	I _F				400	mA	
Power Dissipation	DIP-18	P _D				520	mW
	SOP-18					350	

■ ELECTRICAL CHARACTERISTICS (Ta = 25°C)

PARAMETER	SYMBOL	TEST CIRCUIT	TEST CONDITIONS	MIN	TYP	MAX	UNIT
Output Leakage Current	I _{CEX}	1	V _{CC} = V _{CC(MAX)} , V _{IN} = 0.4V			100	μA
Output Saturation Voltage	V _{CE(SAT)}	2	V _{IN} = V _{IN(ON)} , I _{OUT} = -350mA			2.0	V
			V _{IN} = V _{IN(ON)} , I _{OUT} = -225mA			1.9	V
			V _{IN} = V _{IN(ON)} , I _{OUT} = -100mA			1.8	V
Input Current	I _{IN(ON)}	3	V _{IN} = 2.4V		36	52	μA
			V _{IN} = 3.85V		180	260	μA
Supply Current	I _{CC(ON)}	3	V _{IN} = V _{IN(ON)} , V _{CC} = 50 V			2.5	mA/ch
Input Voltage	V _{IN(ON)}	4	V _{CE} = 2.0V			2.0	V
	V _{IN(OFF)}		I _{OUT} = -500 μA	0.8			V
Clamp Diode Reverse Current	I _R	5	V _R = 50V			50	μA
Clamp Diode Forward Voltage	V _F	6	I _F = 350mA			2.0	V
Turn-On Delay	t _{ON}	7	V _{CC} = V _{CC(MAX)} , R _L = 125Ω C _L = 15pF, R _L = 88Ω		0.15		μs
Turn-Off Delay	t _{OFF}				1.8		μs

■ TEST CIRCUITS

1. I_{CEX}

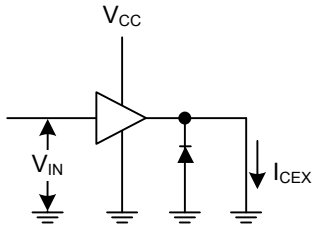

2. $V_{CE(SAT)}$

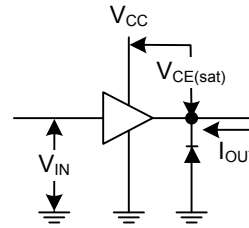

3. $I_{IN(ON)}, I_{CC}$

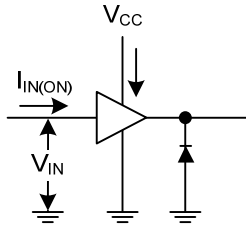

4. $V_{IN(ON)}, V_{IN(OFF)}$

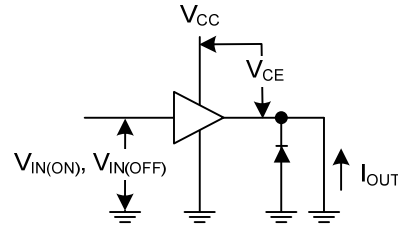

5. I_R

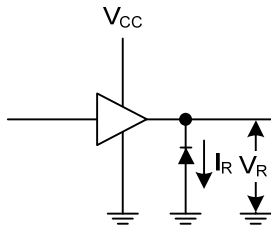

6. V_F

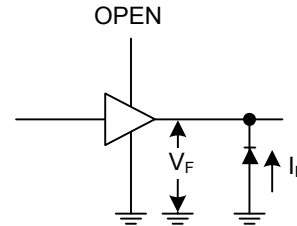

7. t_{ON}, t_{OFF}

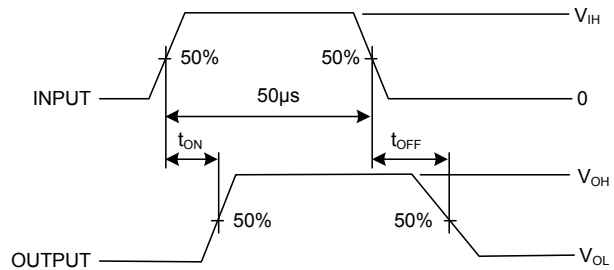
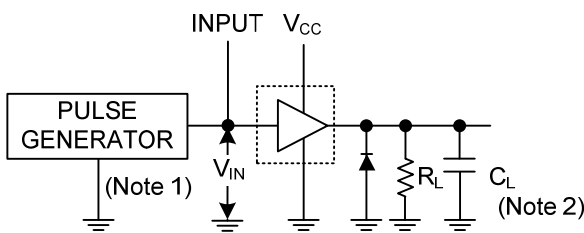

Notes: 1. Pulse width 50 μ s, duty cycle 10% Output impedance 50 Ω , $t_r \leq 5$ ns, $t_f \leq 10$ ns
 2. C_L includes probe and jig capacitance

■ PRECAUTIONS FOR USING

This circuit does not integrate protection circuits such as over-current and overvoltage protectors. Thus, the IC may be damaged if excess current or voltage is occurred to the IC. Make sure the IC design is fine so that excess current or voltage will not be applied to the IC. You must take extreme care to the design of the output line, V_{CC} and GND line because IC may be destroyed under the condition of short-circuit between outputs, air contamination fault, or fault by improper grounding.

UTC assumes no responsibility for equipment failures that result from using products at values that exceed, even momentarily, rated values (such as maximum ratings, operating condition ranges, or other parameters) listed in products specifications of any and all UTC products described or contained herein. UTC products are not designed for use in life support appliances, devices or systems where malfunction of these products can be reasonably expected to result in personal injury. Reproduction in whole or in part is prohibited without the prior written consent of the copyright owner. The information presented in this document does not form part of any quotation or contract, is believed to be accurate and reliable and may be changed without notice.