



62784

Preliminary

LINEAR INTEGRATED CIRCUIT

8CH HIGH-VOLTAGE SOURCE DRIVER

DESCRIPTION

The UTC 62784 consists of eight source current transistor array combination and it is suitable for fluorescent display applications.

The UTC 62784 is ideal for uses, such as relay, hammer and lamp drivers.

FEATURES

- * High output voltage: $V_{CC} = 50V$ (MIN.)
- * Output current (single output): $-500mA$ (MIN.)
- * Output clamp diodes and single supply voltage
- * Input compatible with kinds of types of logic
- * 6~15V PMOS, CMOS
- * Halogen Free

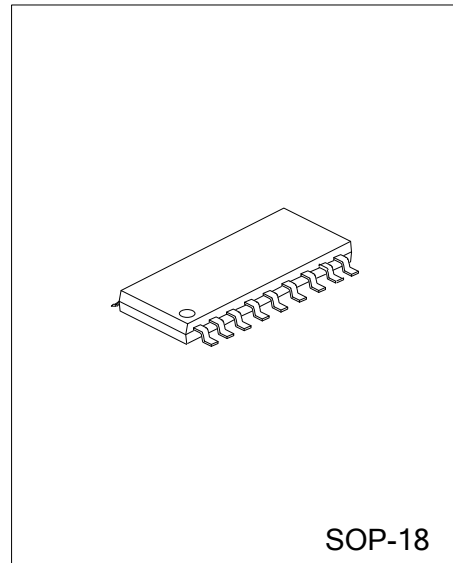

ORDERING INFORMATION

Ordering Number	Package	Packing
62784G-S18-R	SOP-18	Tape Reel

<p>62784G-S18-R</p> <p>(1) Packing Type (2) Package Type (3) Halogen Free</p>	<p>(1) R: Tape Reel (2) S18: SOP-18 (3) G: Halogen Free</p>
---	---

■ PIN CONFIGURATION

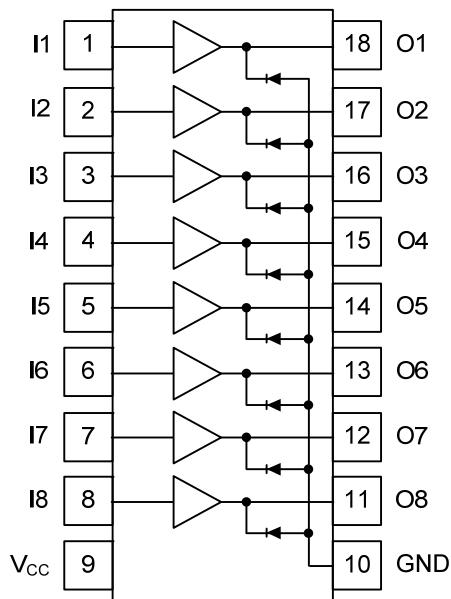

■ SCHEMATICS(EACH DRIVER)

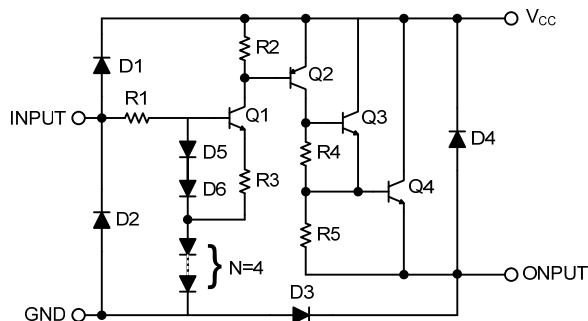

R1	R2	R3	R4	R5
10kΩ	20kΩ	2.6kΩ	10kΩ	5kΩ

Note: The input and output parasitic diodes cannot be used as clamp diodes

■ PIN DESCRIPTION

PIN NO.	PIN NAME	DESCRIPTION
1	I1	Input Of CH1
2	I2	Input Of CH2
3	I3	Input Of CH3
4	I4	Input Of CH4
5	I5	Input Of CH5
6	I6	Input Of CH6
7	I7	Input Of CH7
8	I8	Input Of CH8
9	V _{CC}	Power Supply
10	GND	Ground
11	O8	Output Of CH8
12	O7	Output Of CH7
13	O6	Output Of CH6
14	O5	Output Of CH5
15	O4	Output Of CH4
16	O3	Output Of CH3
17	O2	Output Of CH2
18	O1	Output Of CH1

■ ABSOLUTE MAXIMUM RATING (Ta = 25°C)

PARAMETER	SYMBOL	RATINGS	UNIT
Supply Voltage	V_{CC}	50	V
Input Voltage	V_{IN}	30	V
Clamp Diode Reverse Voltage	V_R	50	V
Output Current	I_{OUT}	-500	mA/ch
Clamp Diode Forward Current	I_F	500	mA
Power Dissipation	P_D	960	mW
Derated Above 25°C		7.7	mW/°C
Operating Temperature	T_{OPR}	-40~+85	°C
Storage Temperature	T_{STG}	-55~+150	°C

Note: Absolute maximum ratings are those values beyond which the device could be permanently damaged. Absolute maximum ratings are stress ratings only and functional device operation is not implied.

■ RECOMMENDED OPERATING CONDITIONS (Ta = -40 ~ +80°C)

PARAMETER	SYMBOL	TEST CONDITIONS	MIN	TYP	MAX	UNIT	
Supply Voltage	V_{CC}				50	V	
Output Current	I_{OUT}	Ta=85°C, Tj=120°C, Tp=25ms			Duty=10%	-180	mA/ch
					Duty=50%	-38	mA/ch
Input Voltage	V_{IN}				24	V	
Input Voltage	Output On	$V_{IN(ON)}$	4.5	12.0	30	V	
	Output Off	$V_{IN(OFF)}$	0		2.0	V	
Clamp Diode Reverse Voltage	V_R				35	V	
Clamp Diode Forward Current	I_F				400	mA	
Power Dissipation	P_D				350	mW	

■ ELECTRICAL CHARACTERISTICS (Ta = 25°C)

PARAMETER	SYMBOL	TEST CIRCUIT	TEST CONDITIONS	MIN	TYP	MAX	UNIT
Output Leakage Current	I_{CEX}	1	$V_{CC} = V_{CC(MAX)}$, $V_{IN} = 0.4V$			100	μA
Output Saturation Voltage	$V_{CE(SAT)}$	2	$V_{IN} = V_{IN(ON)}$, $I_{OUT} = -350mA$			2.0	V
			$V_{IN} = V_{IN(ON)}$, $I_{OUT} = -225mA$			1.9	V
			$V_{IN} = V_{IN(ON)}$, $I_{OUT} = -100mA$			1.8	V
Input Current	$I_{IN(ON)}$	3	$V_{IN} = 5V$		92	130	μA
			$V_{IN} = 12V$		790	1130	μA
Supply Current	$I_{CC(ON)}$	3	$V_{IN} = V_{IN(ON)}$, $V_{CC} = 50V$			2.5	mA/ch
Input Voltage	$V_{IN(ON)}$	4	$I_{OUT} = -350mA$			4.5	V
	$V_{IN(OFF)}$		$I_{OUT} = -500\mu A$	2.0			V
Clamp Diode Reverse Current	I_R	5	$V_R = 50V$			50	μA
Clamp Diode Forward Voltage	V_F	6	$I_F = 350mA$			2.0	V
Turn-On Delay	t_{ON}	7	$V_{CC} = V_{CC(MAX)}$, $R_L = 125\Omega$		0.15		μs
Turn-Off Delay	t_{OFF}		$C_L = 15pF$, $R_L = 88\Omega$		1.8		μs

■ TEST CIRCUITS

1. I_{CEX}

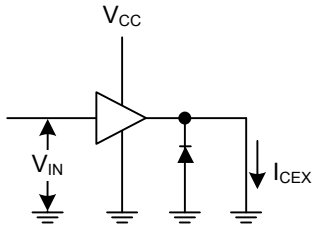

2. $V_{CE(SAT)}$

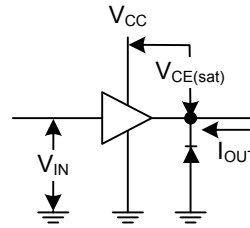

3. $I_{IN(ON)}$, I_{CC}

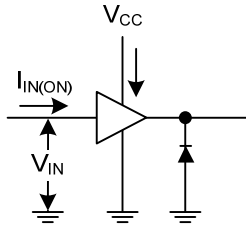

4. $V_{IN(ON)}$, $V_{IN(OFF)}$

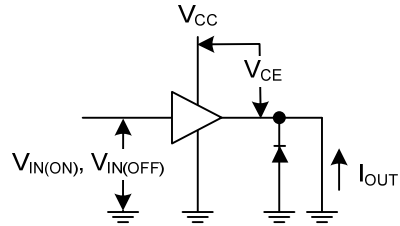

5. I_R

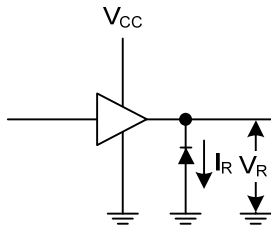

6. V_F

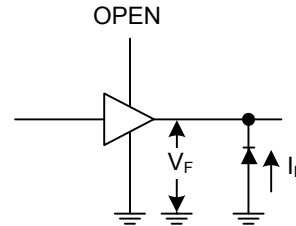

7. t_{ON} , t_{OFF}

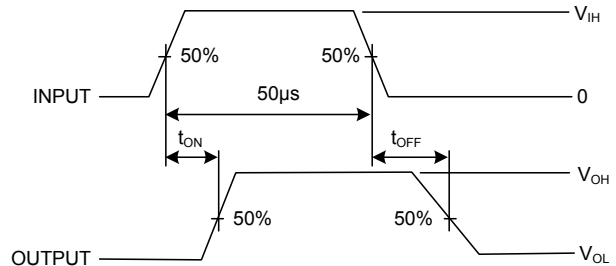
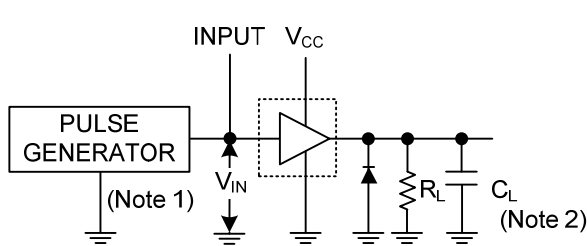

Notes: 1. Pulse width 50 μ s, duty cycle 10% Output impedance 50 Ω , $t_r \leq 5$ ns, $t_f \leq 10$ ns
 2. C_L includes probe and jig capacitance

■ PRECAUTIONS FOR USING

This circuit does not integrate protection circuits such as over-current and overvoltage protectors.

Thus, the IC may be damaged if excess current or voltage is occurred to the IC. Make sure the IC design is fine so that excess current or voltage will not be applied to the IC.

You must take extreme care to the design of the output line, V_{CC} and GND line because IC may be destroyed under the condition of short-circuit between outputs, air contamination fault, or fault by improper grounding.

UTC assumes no responsibility for equipment failures that result from using products at values that exceed, even momentarily, rated values (such as maximum ratings, operating condition ranges, or other parameters) listed in products specifications of any and all UTC products described or contained herein. UTC products are not designed for use in life support appliances, devices or systems where malfunction of these products can be reasonably expected to result in personal injury. Reproduction in whole or in part is prohibited without the prior written consent of the copyright owner. The information presented in this document does not form part of any quotation or contract, is believed to be accurate and reliable and may be changed without notice.