



## 78MXX

Preliminary

LINEAR INTEGRATED CIRCUIT

### 3-TERMINAL 0.5A POSITIVE VOLTAGE REGULATOR

#### DESCRIPTION

The UTC **78MXX** family is monolithic fixed voltage regulator integrated circuit. They are suitable for applications that required supply current up to 0.5A.

#### FEATURES

- \*Output current up to 0.5A
- \*Fixed output voltage of 5V, 6V, 8V, 9V, 12V, 15V, 18V and 24V available
- \*Thermal overload shutdown protection
- \*Short circuit current limiting
- \*Output transistor SOA protection

#### ORDERING INFORMATION

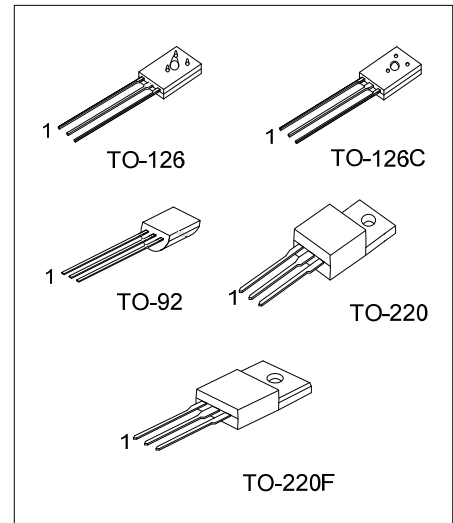

Lead-free: 78MXXL  
Halogen-free: 78MXXG

Order Number			Package	Pin Assignment			Packing
Normal	Lead Free Plating	Halogen Free		1	2	3	
78Mxx-T60-K	78MxxL-T60-K	78MxxG-T60-K	TO-126	I	G	O	Bulk
78Mxx-T6C-K	78MxxL-T6C-K	78MxxG-T6C-K	TO-126C	I	G	O	Bulk
78Mxx-T92-B	78MxxL-T92-B	78MxxG-T92-K	TO-92	O	G	I	Tape Box
78Mxx-T92-K	78MxxL-T92-K	78MxxG-T92-K	TO-92	O	G	I	Bulk
78Mxx-TA3-T	78MxxL-TA3-T	78MxxG-TA3-K	TO-220	I	G	O	Tube
78Mxx-TF3-T	78MxxL-TF3-T	78MxxG-TF3-K	TO-220F	I	G	O	Tube

<p>78MxxL-T60-K</p>	<p>(1) Packing Type (2) Package Type (3) Lead Plating (4) Output Voltage</p> <p>(1) B: Tape Box, K: Bulk, T: Tube (2) T60: TO-126, T6C: TO-126C, T92: TO-92, TA3: TO-220, TF3: TO-220F (3) G: Halogen Free, L: Lead Free Plating, Blank: Pb/Sn (4) xx: refer to Marking Information</p>
---------------------	---

■ MARKING INFORMATION

PACKAGE	VOLTAGE CODE	MARKING
TO-220 TO-220F	05: 5V 06: 6V 08: 8V 09: 9V 12: 12V 15: 15V 18: 18V 24: 24V	
TO-126 TO-126C		
TO-92		



## ■ ABSOLUTE MAXIMUM RATINGS

(Operating temperature range applies unless otherwise specified)

PARAMETER	SYMBOL	RATING	UNIT	
Input Voltage	$V_{IN}$	$V_{OUT}=5\sim 18V$	35	V
		$V_{OUT}=24V$	40	V
Output Current	$I_{OUT}$	0.5	A	
Power Dissipation	$P_D$	Internally Limited	W	
Operating Junction Temperature Range	$T_{OPR}$	-20 ~ +125	°C	
Storage Temperature Range	$T_{STG}$	-65 ~ +150	°C	

Note Absolute maximum ratings are those values beyond which the device could be permanently damaged.

Absolute maximum ratings are stress ratings only and functional device operation is not implied.

## ■ ELECTRICAL CHARACTERISTICS

### FOR UTC78M05

(Refer to the test circuits,  $T_{MIN} \leq T_J \leq 125^\circ C$ ,  $I_{OUT}=350mA$ ,  $V_{IN}=10V$ , unless otherwise specified,  $C_i=0.33\mu F$ ,  $C_o=0.1\mu F$ )

PARAMETER	SYMBOL	TEST CONDITIONS	MIN	TYP	MAX	UNIT
Output Voltage	$V_{OUT}$	$T_J=25^\circ C$	4.80	5.0	5.20	V
		$I_{OUT}=5mA \sim 350mA$ $V_{IN}=7 \sim 20V$	4.75		5.25	V
Load Regulation	$\Delta V_{OUT}$	$T_J=25^\circ C$ , $I_{OUT}=5mA-0.5A$			100	mV
		$T_J=25^\circ C$ , $I_{OUT}=5mA-200mA$			50	mV
Line regulation	$\Delta V_{OUT}$	$V_{IN}=7 \sim 25V$ , $T_J=25^\circ C$ , $I_{OUT}=200mA$			100	mV
		$V_{IN}=8 \sim 25V$ , $T_J=25^\circ C$ , $I_{OUT}=200mA$			50	mV
Quiescent Current	$I_Q$	$T_J=25^\circ C$		4.0	6.0	mA
Quiescent Current Change	$\Delta I_Q$	$V_{IN}=8 \sim 25V$ , $I_{OUT}=200mA$			0.8	mA
		$I_{OUT}=5mA-350mA$			0.5	mA
Output Noise Voltage	eN	$10Hz \leq f \leq 100KHz$		40		uV
Ripple Rejection	RR	$V_{IN}=8 \sim 18V$ , $f=120Hz$ $I_{OUT}=300mA$	62			dB
Peak Output Current	$I_{PEAK}$	$T_J=25^\circ C$		700		mA
Short-Circuit Current	$I_{SC}$	$V_{IN}=35V$ , $T_J=25^\circ C$		300		mA
Dropout Voltage	$V_D$	$T_J=25^\circ C$ , $I_{OUT}=500mA$		2.0		V

### FOR UTC78M06

(Refer to the test circuits,  $T_{MIN} \leq T_J \leq 125^\circ C$ ,  $I_{OUT}=350mA$ ,  $V_{IN}=11V$ , unless otherwise specified,  $C_i=0.33\mu F$ ,  $C_o=0.1\mu F$ )

PARAMETER	SYMBOL	TEST CONDITIONS	MIN	TYP	MAX	UNIT
Output Voltage	$V_{OUT}$	$T_J=25^\circ C$ , $I_{OUT}=5-350mA$	5.76	6.0	6.24	V
		$V_{IN}=8 \sim 21V$ , $I_{OUT}=5mA-350mA$	5.70		6.30	V
Load Regulation	$\Delta V_{OUT}$	$T_J=25^\circ C$ , $I_{OUT}=5mA-0.5A$			120	mV
		$T_J=25^\circ C$ , $I_{OUT}=5mA-200mA$			60	mV
Line regulation	$\Delta V_{OUT}$	$V_{IN}=8V \sim 25V$ , $T_J=25^\circ C$ , $I_{OUT}=200mA$			100	mV
		$V_{IN}=9V \sim 25V$ , $T_J=25^\circ C$ , $I_{OUT}=200mA$			50	mV
Quiescent Current	$I_Q$	$T_J=25^\circ C$		4.0	6	mA
Quiescent Current Change	$\Delta I_Q$	$I_{OUT}=5mA \sim 350mA$			0.5	mA
		$V_{IN}=9V \sim 25V$ , $I_{OUT}=200mA$			0.8	mA
Output Noise Voltage	eN	$10Hz \leq f \leq 100KHz$		45		uV
Ripple Rejection	RR	$V_{IN}=9V \sim 19V$ , $f=120Hz$ , $T_J=25^\circ C$ $I_{OUT}=300mA$	59			dB
Peak Output Current	$I_{PEAK}$	$T_J=25^\circ C$		700		mA
Short-Circuit Current	$I_{SC}$	$V_{IN}=35V$ , $T_J=25^\circ C$		300		mA
Dropout Voltage	$V_D$	$T_J=25^\circ C$		2.0		V

■ ELECTRICAL CHARACTERISTICS (Cont.)

**FOR UTC78M08**

(Refer to the test circuits,  $T_{MIN} \leq T_J \leq 125^\circ\text{C}$ ,  $I_{OUT}=350\text{mA}$ ,  $V_{IN}=14\text{V}$ , unless otherwise specified,  $C_i=0.33\mu\text{F}$ ,  $C_o=0.1\mu\text{F}$ )

PARAMETER	SYMBOL	TEST CONDITIONS	MIN	TYP	MAX	UNIT
Output Voltage	$V_{OUT}$	$T_J=25^\circ\text{C}$	7.68	8.0	8.32	V
		$V_{IN}=10.5\text{V} \sim 23\text{V}$ , $I_{OUT}=5\text{mA}-350\text{mA}$	7.60		8.40	V
Load Regulation	$\Delta V_{OUT}$	$T_J=25^\circ\text{C}$ , $I_{OUT}=5\text{mA}-0.5\text{A}$			160	mV
		$T_J=25^\circ\text{C}$ , $I_{OUT}=5\text{mA}-200\text{mA}$			80	mV
Line regulation	$\Delta V_{OUT}$	$V_{IN}=10.5\text{V} \sim 25\text{V}$ $T_J=25^\circ\text{C}$ , $I_{OUT}=200\text{mA}$			100	mV
		$V_{IN}=11\text{V} \sim 25\text{V}$ $T_J=25^\circ\text{C}$ , $I_{OUT}=200\text{mA}$			50	mV
Quiescent Current	$I_Q$	$T_J=25^\circ\text{C}$		4.0	6	mA
Quiescent Current Change	$\Delta I_Q$	$V_{IN}=10.5\text{V} \sim 25\text{V}$ , $I_{OUT}=200\text{mA}$			0.8	mA
		$I_{OUT}=5\text{mA} \sim 350\text{mA}$			0.5	mA
Output Noise Voltage	eN	$10\text{Hz} < f < 100\text{KHz}$		52		$\mu\text{V}$
Ripple Rejection	RR	$V_{IN}=11.5\text{V} \sim 21.5\text{V}$ , $f=120\text{Hz}$ , $I_{OUT}=300\text{mA}$	56			dB
Peak Output Current	$I_{PEAK}$	$T_J=25^\circ\text{C}$		700		mA
Short-Circuit Current	$I_{SC}$	$V_{IN}=35\text{V}$ , $T_J=25^\circ\text{C}$		300		mA
Dropout Voltage	$V_D$	$T_J=25^\circ\text{C}$ , $I_{OUT}=500\text{mA}$		2.0		V

**FOR UTC78M09**

(Refer to the test circuits,  $T_{MIN} \leq T_J \leq 125^\circ\text{C}$ ,  $I_{OUT}=350\text{mA}$ ,  $V_{IN}=17\text{V}$ , unless otherwise specified,  $C_i=0.33\mu\text{F}$ ,  $C_o=0.1\mu\text{F}$ )

PARAMETER	SYMBOL	TEST CONDITIONS	MIN	TYP	MAX	UNIT
Output Voltage	$V_{OUT}$	$T_J=25^\circ\text{C}$	8.64	9	9.36	V
		$V_{IN}=12.5\text{V} \sim 25\text{V}$ , $I_{OUT}=5\text{mA}-350\text{mA}$	8.55		9.45	V
Load Regulation	$\Delta V_{OUT}$	$T_J=25^\circ\text{C}$ , $I_{OUT}=5\text{mA}-0.5\text{A}$			200	mV
		$T_J=25^\circ\text{C}$ , $I_{OUT}=5\text{mA}-200\text{mA}$			100	mV
Line regulation	$\Delta V_{OUT}$	$V_{IN}=12.5\text{V} \sim 25\text{V}$ $T_J=25^\circ\text{C}$ , $I_{OUT}=200\text{mA}$			100	mV
		$V_{IN}=13\text{V} \sim 25\text{V}$ $T_J=25^\circ\text{C}$ , $I_{OUT}=200\text{mA}$			50	mV
Quiescent Current	$I_Q$	$T_J=25^\circ\text{C}$		4.1	6	mA
Quiescent Current Change	$\Delta I_Q$	$V_{IN}=12.5\text{V} \sim 25\text{V}$ , $I_{OUT}=200\text{mA}$			0.8	mA
		$I_{OUT}=5\text{mA}-350\text{mA}$			0.5	mA
Output Noise Voltage	eN	$10\text{Hz} < f < 100\text{kHz}$		65		$\mu\text{V}$
Ripple Rejection	RR	$V_{IN}=13\text{V} \sim 23\text{V}$ , $f=120\text{Hz}$ $I_{OUT}=300\text{mA}$	55			dB
Peak Output Current	$I_{PEAK}$	$T_J=25^\circ\text{C}$		700		mA
Short-Circuit Current	$I_{SC}$	$V_{IN}=35\text{V}$ , $T_J=25^\circ\text{C}$		300		mA
Dropout Voltage	$V_D$	$T_J=25^\circ\text{C}$ , $I_{OUT}=500\text{mA}$		2.0		V

■ ELECTRICAL CHARACTERISTICS (Cont.)

**FOR UTC78M12**

(Refer to the test circuits,  $T_{MIN} \leq T_J \leq 125^\circ\text{C}$ ,  $I_{OUT}=350\text{mA}$ ,  $V_{IN}=19\text{V}$ , unless otherwise specified,  $C_i=0.33\mu\text{F}$ ,  $C_o=0.1\mu\text{F}$ )

PARAMETER	SYMBOL	TEST CONDITIONS	MIN	TYP	MAX	UNIT
Output Voltage	$V_{OUT}$	$T_J=25^\circ\text{C}$	11.52	12.0	12.48	V
		$V_{IN}=14.5\text{V to }27\text{V}$ , $I_{OUT}=5\text{mA-}350\text{mA}$	11.40		12.60	V
Load Regulation	$\Delta V_{OUT}$	$T_J=25^\circ\text{C}, I_{OUT}=5\text{mA-}0.5\text{A}$			240	mV
		$T_J=25^\circ\text{C}, I_{OUT}=5\text{mA-}2\text{A}$			120	mV
Line regulation	$\Delta V_{OUT}$	$V_{IN}=14.5\text{V to }30\text{V}$ $T_J=25^\circ\text{C}, I_{OUT}=200\text{mA}$			100	mV
		$V_{IN}=16\text{V to }30\text{V}$ $T_J=25^\circ\text{C}, I_{OUT}=200\text{mA}$			50	mV
Quiescent Current	$I_Q$	$T_J=25^\circ\text{C}$		4.1	6.0	mA
Quiescent Current Change	$\Delta I_Q$	$V_{IN}=14.5\text{V to }30\text{V}, I_{OUT}=200\text{mA}$			0.8	mA
		$I_{OUT}=5\text{mA-}350\text{mA}$			0.5	mA
Output Noise Voltage	eN	$10\text{Hz} < f <= 100\text{kHz}$		75		$\mu\text{V}$
Ripple Rejection	RR	$V_{IN}=15\text{V to }25\text{V}, f=120\text{Hz}$ $I_{OUT}=300\text{mA}$	55			dB
Peak Output Current	$I_{PEAK}$	$T_J=25^\circ\text{C}$		700		mA
Short-Circuit Current	$I_{SC}$	$V_{IN}=35\text{V}, T_J=25^\circ\text{C}$		300		mA
Dropout Voltage	$V_D$	$T_J=25^\circ\text{C}, I_{OUT}=500\text{mA}$		2.0		V

**FOR UTC78M15**

(Refer to the test circuits,  $T_{MIN} \leq T_J \leq 125^\circ\text{C}$ ,  $I_{OUT}=350\text{mA}$ ,  $V_{IN}=23\text{V}$ , unless otherwise specified,  $C_i=0.33\mu\text{F}$ ,  $C_o=0.1\mu\text{F}$ )

PARAMETER	SYMBOL	TEST CONDITIONS	MIN	TYP	MAX	UNIT
Output Voltage	$V_{OUT}$	$T_J=25^\circ\text{C}$	14.40	15.0	15.60	V
		$V_{IN}=17.5\text{V} \sim 30\text{V}$ , $I_{OUT}=5\text{mA-}350\text{mA}$	14.25		15.75	V
Load Regulation	$\Delta V_{OUT}$	$T_J=25^\circ\text{C}, I_{OUT}=5\text{mA-}0.5\text{A}$			300	mV
		$T_J=25^\circ\text{C}, I_{OUT}=5\text{mA-}200\text{mA}$			150	mV
Line regulation	$\Delta V_{OUT}$	$V_{IN}=17.5\text{V} \sim 30\text{V}$ $T_J=25^\circ\text{C}, I_{OUT}=200\text{mA}$			100	mV
		$V_{IN}=20\text{V} \sim 30\text{V}$ $T_J=25^\circ\text{C}, I_{OUT}=200\text{mA}$			50	mV
Quiescent Current	$I_Q$	$T_J=25^\circ\text{C}$		4.1	6.0	mA
Quiescent Current Change	$\Delta I_Q$	$V_{IN}=17.5\text{V} \sim 30\text{V}, I_{OUT}=200\text{mA}$			0.8	mA
		$I_{OUT}=5\text{mA-}350\text{mA}$			0.5	mA
Output Noise Voltage	eN	$10\text{Hz} < f <= 100\text{KHz}$		90		$\mu\text{V}$
Ripple Rejection	RR	$V_{IN}=18.5\text{V} \sim 28.5\text{V}$ $f=120\text{Hz}, I_{OUT}=300\text{mA}$	54			dB
Peak Output Current	$I_{PEAK}$	$T_J=25^\circ\text{C}$		700		mA
Short-Circuit Current	$I_{SC}$	$V_{IN}=35\text{V}, T_J=25^\circ\text{C}$		300		mA
Dropout Voltage	$V_D$	$T_J=25^\circ\text{C}, I_{OUT}=500\text{mA}$		2.0		V

■ ELECTRICAL CHARACTERISTICS (Cont.)

**FOR 78M18**

(Refer to the test circuits,  $T_{MIN} \leq T_J \leq 125^\circ\text{C}$ ,  $I_{OUT}=350\text{mA}$ ,  $V_{IN}=26\text{V}$ , unless otherwise specified,  $C_i=0.33\mu\text{F}$ ,  $C_o=0.1\mu\text{F}$ )

PARAMETER	SYMBOL	TEST CONDITIONS	MIN	TYP	MAX	UNIT
Output Voltage	$V_{OUT}$	$T_J = 25^\circ\text{C}$	17.28	18.0	18.72	V
		$V_{IN} = 20.5\text{V to } 33\text{V}$ $I_{OUT} = 5\text{mA-}350\text{mA}$	17.10		18.90	V
Load Regulation	$\Delta V_{OUT}$	$T_J = 25^\circ\text{C}, I_{OUT} = 5\text{mA-}0.5\text{A}$			360	mV
		$T_J = 25^\circ\text{C}, I_{OUT} = 5\text{mA-}200\text{mA}$			180	mV
Line regulation	$\Delta V_{OUT}$	$V_{IN} = 21\text{V to } 33\text{V}$ $T_J = 25^\circ\text{C}, I_{OUT} = 200\text{mA}$			100	mV
		$V_{IN} = 24\text{V to } 33\text{V}$ , $T_J = 25^\circ\text{C}, I_{OUT} = 200\text{mA}$			50	mV
Quiescent Current	$I_Q$	$T_J = 25^\circ\text{C}$		4.2	6	mA
Quiescent Current Change	$\Delta I_Q$	$V_{IN} = 21\text{V to } 33\text{V}, I_{OUT} = 200\text{mA}$			0.8	mA
		$I_{OUT} = 5\text{mA-}350\text{mA}$			0.5	mA
Output Noise Voltage	eN	$10\text{Hz} < f <= 100\text{KHz}$		100		$\mu\text{V}$
Ripple Rejection	RR	$V_{IN} = 22\text{V to } 32\text{V}, f = 120\text{Hz}$ $I_{OUT} = 300\text{mA}$	53			dB
Peak Output Current	$I_{PEAK}$	$T_J = 25^\circ\text{C}$		700		mA
Short-Circuit Current	$I_{SC}$	$V_{IN} = 35\text{V}, T_J = 25^\circ\text{C}$		300		mA
Dropout Voltage	$V_D$	$T_J = 25^\circ\text{C}$		2.0		V

**FOR 78M24**

(Refer to the test circuits,  $T_{MIN} \leq T_J \leq 125^\circ\text{C}$ ,  $I_{OUT}=350\text{mA}$ ,  $V_{IN}=33\text{V}$ , unless otherwise specified,  $C_i=0.33\mu\text{F}$ ,  $C_o=0.1\mu\text{F}$ )

PARAMETER	SYMBOL	TEST CONDITIONS	MIN	TYP	MAX	UNIT
Output Voltage	$V_{OUT}$	$T_J = 25^\circ\text{C}$	23.04	24.0	24.96	V
		$V_{IN} = 27\text{V to } 38\text{V}$ $I_{OUT} = 5\text{mA-}350\text{mA}$	22.80		25.20	V
Load Regulation	$\Delta V_{OUT}$	$T_J = 25^\circ\text{C}, I_{OUT} = 5\text{mA-}0.5\text{A}$			480	mV
		$T_J = 25^\circ\text{C}, I_{OUT} = 5\text{mA-}200\text{mA}$			240	mV
Line regulation	$\Delta V_{OUT}$	$V_{IN} = 27\text{V to } 38\text{V}$ $T_J = 25^\circ\text{C}, I_{OUT} = 200\text{mA}$			100	mV
		$V_{IN} = 28\text{V to } 38\text{V}$ $T_J = 25^\circ\text{C}, I_{OUT} = 200\text{mA}$			50	mV
Quiescent Current	$I_Q$	$T_J = 25^\circ\text{C}$ ,		4.2	6.0	mA
Quiescent Current Change	$\Delta I_Q$	$V_{IN} = 27\text{V to } 38\text{V}, I_{OUT} = 200\text{mA}$			0.8	mA
		$I_{OUT} = 5\text{mA-}350\text{mA}$			0.5	mA
Output Noise Voltage	eN	$10\text{Hz} < f <= 100\text{KHz}$		170		$\mu\text{V}$
Ripple Rejection	RR	$V_{IN} = 28\text{V to } 38\text{V}, f = 120\text{Hz}$ $I_{OUT} = 300\text{mA}$	50			dB
Peak Output Current	$I_{PEAK}$	$T_J = 25^\circ\text{C}$		700		mA
Short-Circuit Current	$I_{SC}$	$V_{IN} = 35\text{V}, T_J = 25^\circ\text{C}$		300		mA
Dropout Voltage	$V_D$	$T_J = 25^\circ\text{C}$		2.0		V

Note 1: The Maximum steady state usable output current are dependent on input voltage, heat sinking, lead length of the package and copper pattern of PCB. The data above represents pulse test conditions with junction temperatures specified at the initiation of test.

Note 2: Power dissipation < 0.5W

## ■ APPLICATION CIRCUIT

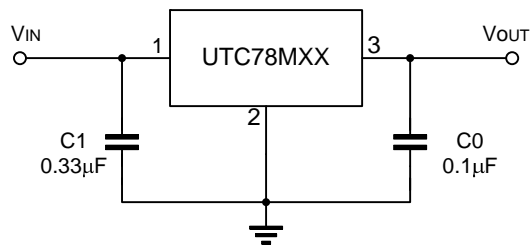

Note 1: To specify an output voltage, substitute voltage value for "MXX".

Note 2: Bypass capacitors are recommended for optimum stability and transient response and should be located as close as possible to the regulators.

UTC assumes no responsibility for equipment failures that result from using products at values that exceed, even momentarily, rated values (such as maximum ratings, operating condition ranges, or other parameters) listed in products specifications of any and all UTC products described or contained herein. UTC products are not designed for use in life support appliances, devices or systems where malfunction of these products can be reasonably expected to result in personal injury. Reproduction in whole or in part is prohibited without the prior written consent of the copyright owner. The information presented in this document does not form part of any quotation or contract, is believed to be accurate and reliable and may be changed without notice.