



78RXX

LINEAR INTEGRATED CIRCUIT

**LOW DROPOUT VOLTAGE
REGULATOR**

■ **DESCRIPTION**

As the UTC linear integrated LDO, the UTC **78RXX** shows a high current, high accuracy, and specially low-dropout voltage. The features are: maximum 500mV dropout voltage, very low ground current. Cause the series have been designed for high current loads, so they are also used in lower current, extremely low dropout-critical systems (in which their tiny dropout voltage and ground current values are important attributes).

■ **FEATURES**

- * $I_{OUT}=1A$; $V_{OUT}=3.3V,5V,9V$ (typ)
- * With ADJ version
- * Internal overcurrent protection, internal thermal shutdown
- * Internal overvoltage protection, internal short-circuit protection
- * Output disable function

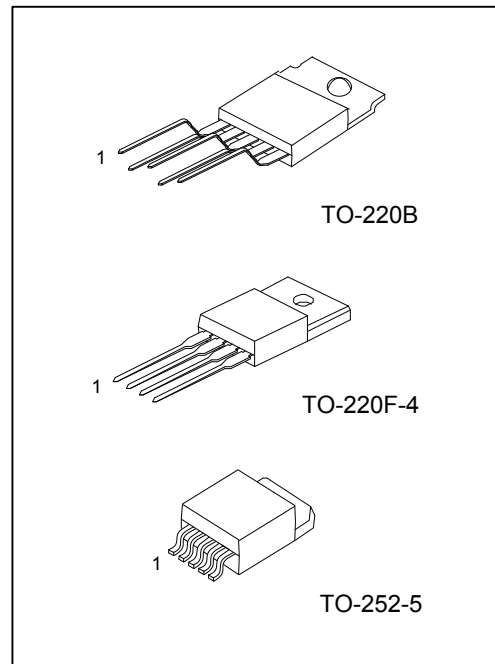

■ **ORDERING INFORMATION**

Ordering Number		Package	Packing
Lead Free	Halogen Free		
78RXXL-TB5-T	78RXXG-TB5-T	TO-220B	Tube
78RXXL-TF4-T	78RXXG-TF4-T	TO-220F-4	Tube
78RXXL-TN5-R	78RXXG-TN5-R	TO-252-5	Tape Reel

Note: xx: output voltage, refer to Marking Information

<p>78RXXL-TB5-T</p>	<p>(1) Packing Type</p> <p>(2) Package Type</p> <p>(3) Lead Plating</p> <p>(4) Voltage Code</p>	<p>(1) R: Tape Reel, T: Tube</p> <p>(2) TB5: TO-220B, TF4: TO-220F-4, TN5: TO-252-5</p> <p>(3) G: Halogen Free, L: Lead Free</p> <p>(4) xx: refer to Marking Information</p>
---------------------	---	--

■ BLOCK DIAGRAM

Fixed Output Voltage Versions

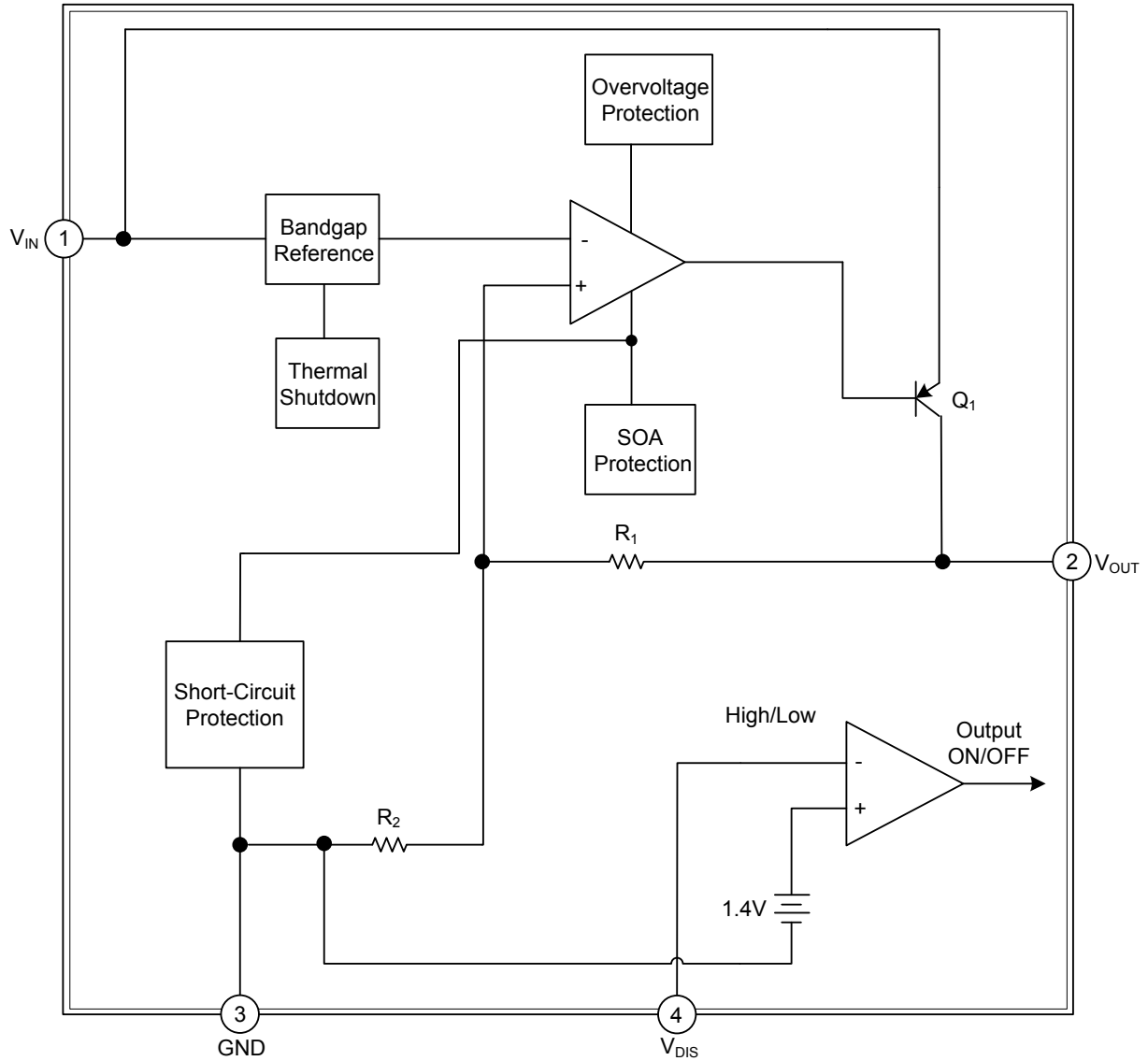

■ BLOCK DIAGRAM

Adjustable Output Voltage Versions

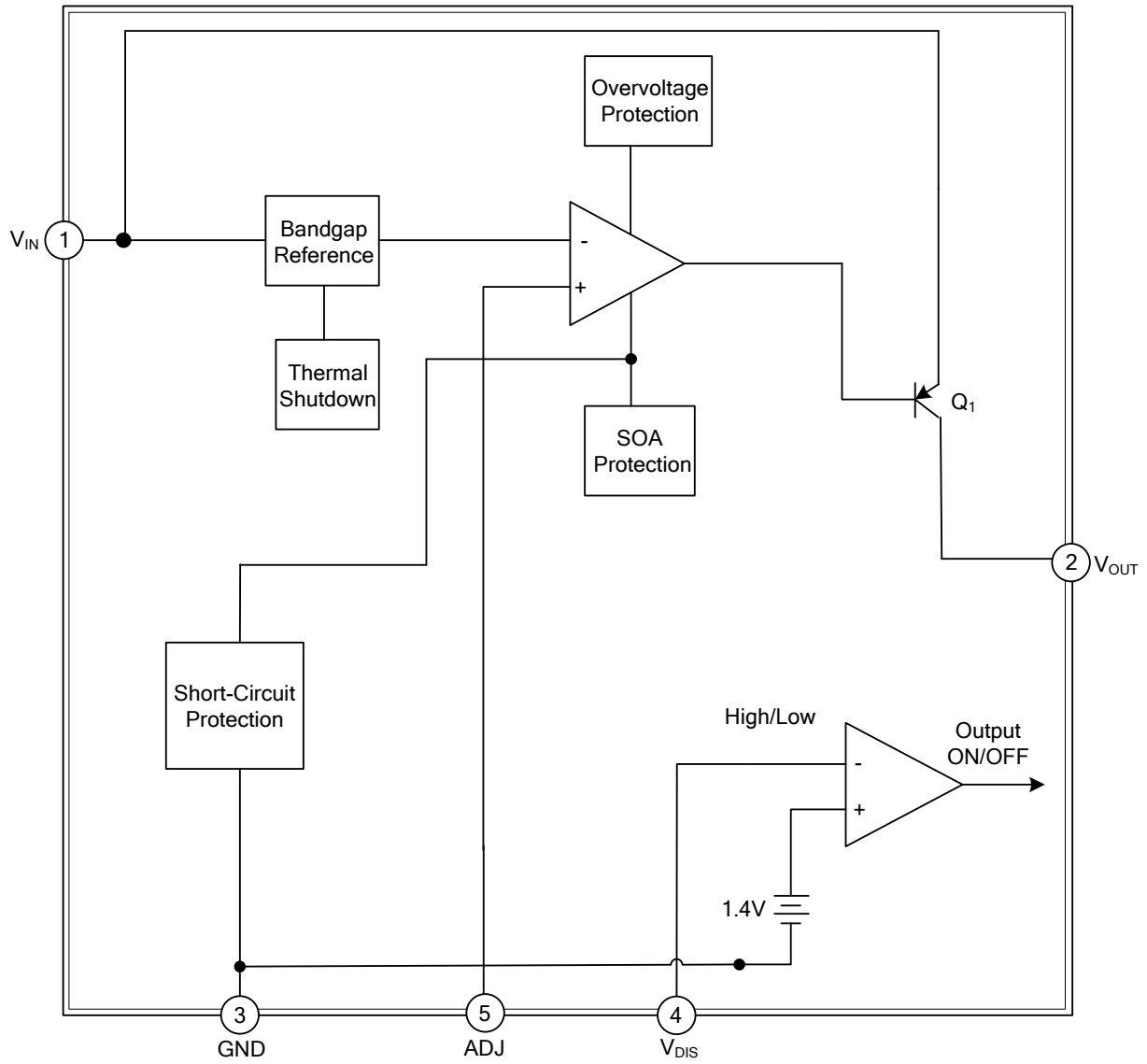

■ ABSOLUTE MAXIMUM RATINGS (Operating temperature range applies unless otherwise specified.)

PARAMETER		SYMBOL	RATINGS	UNITS
Input Voltage		V_{IN}	35	V
Disable Voltage		V_{DIS}	35	V
Output Current		I_{OUT}	1.0	A
Power Dissipation	TO-220B/TO-220F-4	P_D	1.5	W
	TO-252-5		1	W
Junction Temperature		T_J	+150	°C
Operating Temperature		T_{OPR}	-20 ~ +80	°C

Note: Absolute maximum ratings are those values beyond which the device could be permanently damaged.
Absolute maximum ratings are stress ratings only and functional device operation is not implied.

■ THERMAL DATA

PARAMETER		SYMBOL	RATING	UNIT
Junction to Ambient	TO-220B	θ_{JA}	62.5	°C/W
	TO-220F-4		62.5	°C/W
	TO-252-5		110	°C/W
Junction to Case	TO-220B	θ_{JC}	1.67	°C/W
	TO-220F-4		3.68	°C/W
	TO-252-5		2.5	°C/W

■ ELECTRICAL CHARACTERISTICS ($I_{OUT}=0.5A$, $T_A = 25^\circ C$, unless otherwise specified)

For 78R33 ($V_{IN}=5V$)

PARAMETER		SYMBOL	CONDITIONS	MIN	TYP	MAX	UNITS
Output Voltage		V_{OUT}	$V_{IN} = 5V$	3.22	3.3	3.38	V
Dropout Voltage		V_D	$I_{OUT} = 1A$			0.5	V
Load Regulation		ΔV_{OUT}	$5mA < I_{OUT} < 1A$		0.1	2.0	%
Line Regulation		ΔV_{OUT}	$4V < V_{IN} < 10V$		0.5	2.5	%
Quiescent Current		I_Q	$I_{OUT} = 0 A$			10	mA
Ripple Rejection		RR	(Note)	45	55		dB
Disable Voltage	High	V_{DISH}	Output Active	2.0			V
	Low	V_{DISL}	Output Disabled			0.8	V
Disable Bias Current	High	I_{DISH}	$V_{DIS} = 2.7V$			0.02	mA
	Low	I_{DISL}	$V_{DIS} = 0.4V$			-0.4	mA

For 78R05 ($V_{IN}=7V$)

PARAMETER		SYMBOL	CONDITIONS	MIN	TYP	MAX	UNITS
Output Voltage		V_{OUT}	$V_{IN} = 7V$	4.88	5	5.12	V
Dropout Voltage		V_D	$I_{OUT} = 1A$			0.5	V
Load Regulation		ΔV_{OUT}	$5mA < I_{OUT} < 1A$		0.1	2.0	%
Line Regulation		ΔV_{OUT}	$6V < V_{IN} < 12V$		0.5	2.5	%
Quiescent Current		I_Q	$I_{OUT} = 0 A$			10	mA
Ripple Rejection		RR	(Note)	45	55		dB
Disable Voltage	High	V_{DISH}	Output Active	2.0			V
	Low	V_{DISL}	Output Disabled			0.8	V
Disable Bias Current	High	I_{DISH}	$V_{DIS} = 2.7V$			0.02	mA
	Low	I_{DISL}	$V_{DIS} = 0.4V$			-0.4	mA

■ ELECTRICAL CHARACTERISTICS(Cont.)

For 78R09 ($V_{IN}=11V$)

PARAMETER	SYMBOL	CONDITIONS	MIN	TYP	MAX	UNITS
Output Voltage	V_{OUT}	$V_{IN} = 11V$	8.78	9	9.22	V
Dropout Voltage	V_D	$I_{OUT} = 1A$			0.5	V
Load Regulation	ΔV_{OUT}	$5mA < I_{OUT} < 1A$		0.1	2.0	%
Line Regulation	ΔV_{OUT}	$10V < V_{IN} < 25V$		0.5	2.5	%
Quiescent Current	I_Q	$I_{OUT} = 0 A$			10	mA
Ripple Rejection	RR	(Note)	45	55		Db
Disable Voltage	High	V_{DISH}	Output Active			V
	Low	V_{DISL}	Output Disabled		0.8	V
Disable Bias Current	High	I_{DISH}	$V_{DIS} = 2.7V$		0.02	mA
	Low	I_{DISL}	$V_{DIS} = 0.4V$		-0.4	mA

For 78R00-ADJ

PARAMETER	SYMBOL	CONDITIONS	MIN	TYP	MAX	UNITS
Output Voltage	V_{OUT}		1.22	1.25	1.28	V
Dropout Voltage	V_D	$I_{OUT} = 1A$			0.5	V
Load Regulation	ΔV_{OUT}	$5mA < I_{OUT} < 1A$		0.1	2.0	%
Line Regulation	ΔV_{OUT}	$V_o+1V < V_{IN} < V_o+7V$		0.5	2.5	%
Quiescent Current	I_Q	$I_{OUT} = 0 A$			10	mA
Ripple Rejection	RR	(Note)	45	55		dB
Disable Voltage	High	V_{DISH}	Output Active		2.0	V
	Low	V_{DISL}	Output Disabled			0.8 V
Disable Bias Current	High	I_{DISH}	$V_{DIS} = 2.7V$		0.02	mA
	Low	I_{DISL}	$V_{DIS} = 0.4V$		-0.4	mA

Note: These guaranteed parameters, are not 100% tested in production.

■ TYPICAL APPLICATION CIRCUIT

Fixed Output Voltage Versions

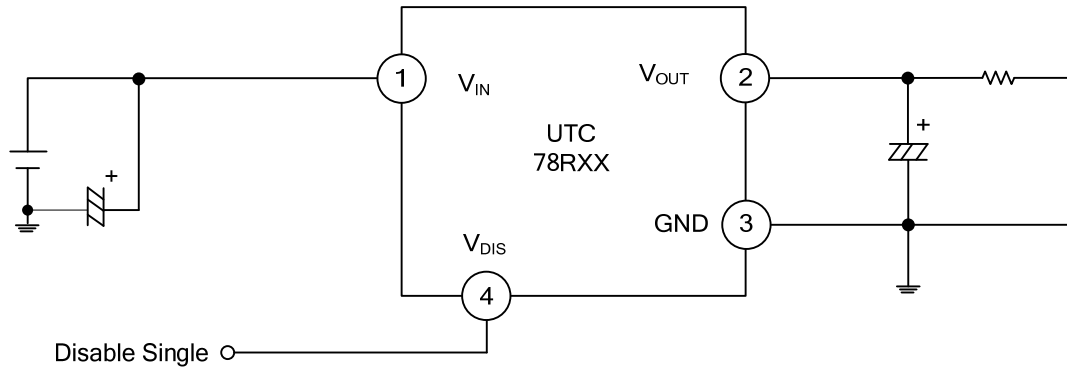

- * C_1 is required if regulator is located an appreciable distance from power supply filter. [$C_1 > 0.33\mu\text{F}$ (Electrolytic)]
- * C_o improves stability and transient response. [$C_o > 47\mu\text{F}$ (Electrolytic)]

Adjustable Output Voltage Version

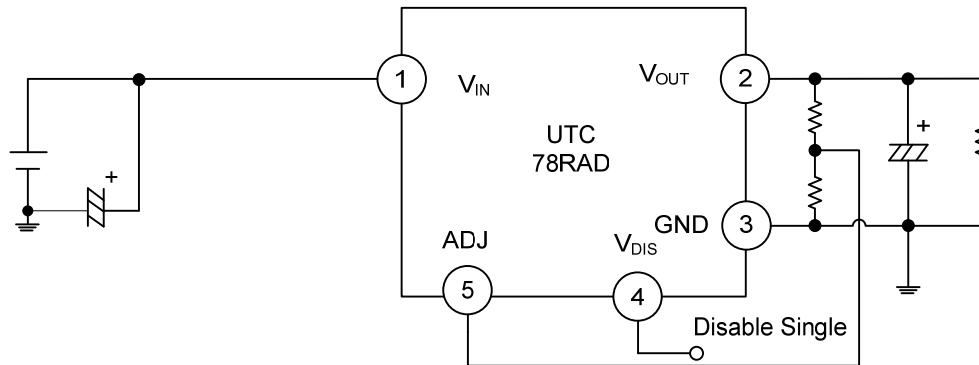

- * C_1 is required if regulator is located an appreciable distance from power supply filter. [$C_1 > 0.33\mu\text{F}$ (Electrolytic)]
- * C_o improves stability and transient response. [$C_o > 47\mu\text{F}$ (Electrolytic)]

■ TYPICAL CHARACTERISTICS

(1) 78R33

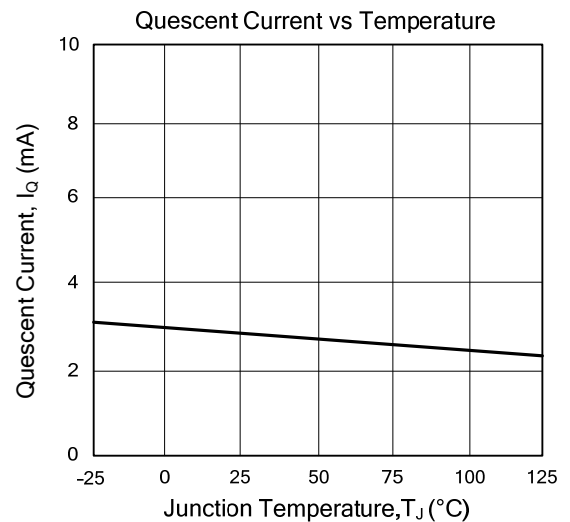
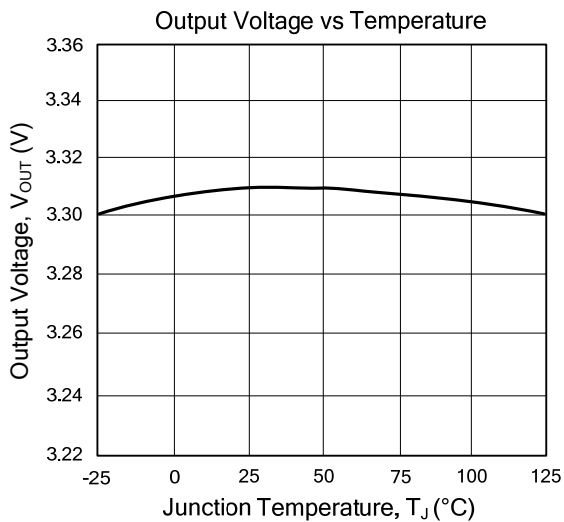
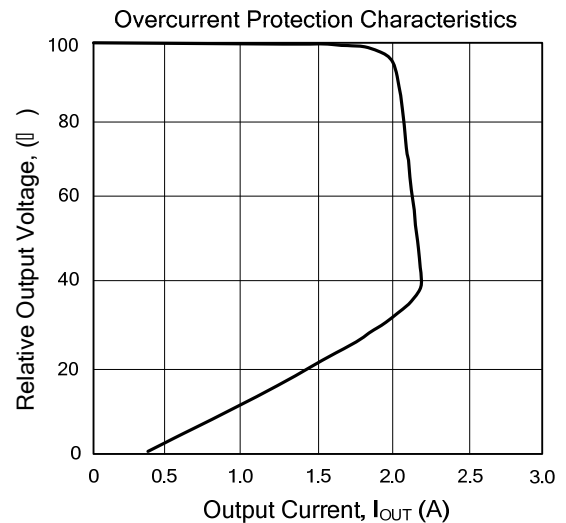
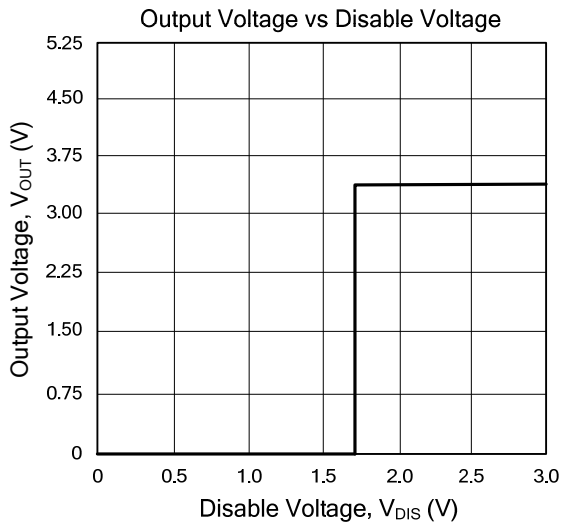
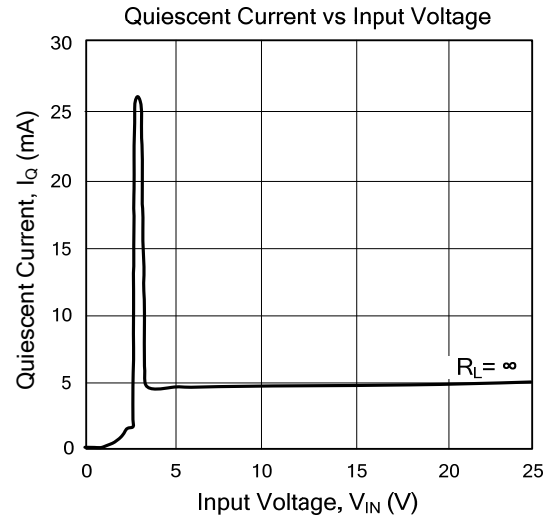
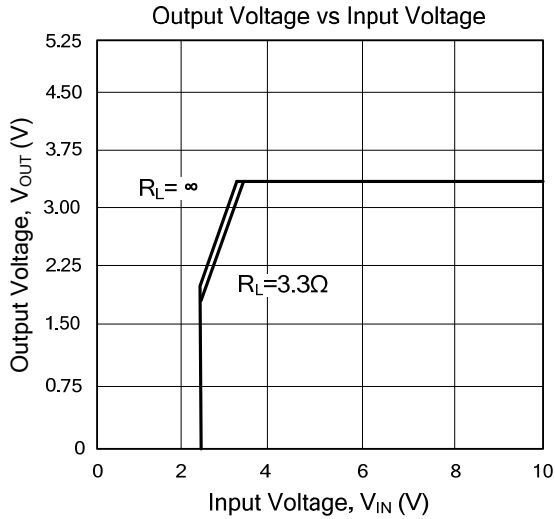

■ TYPICAL CHARACTERISTICS(Cont.)

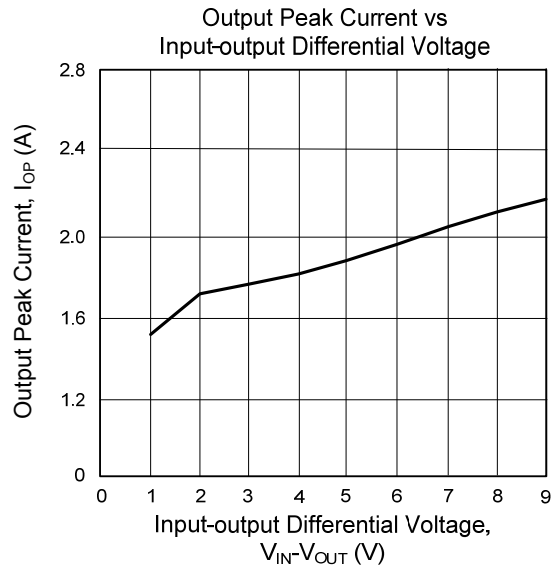

(2) 78R05

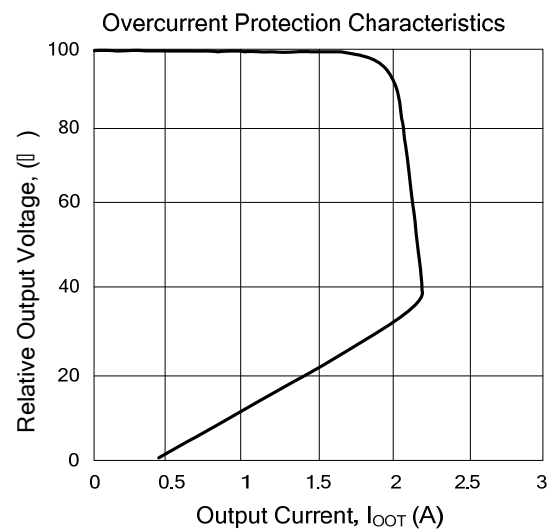
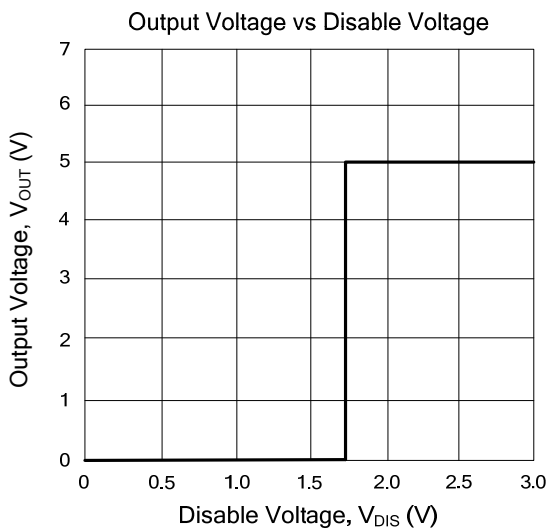
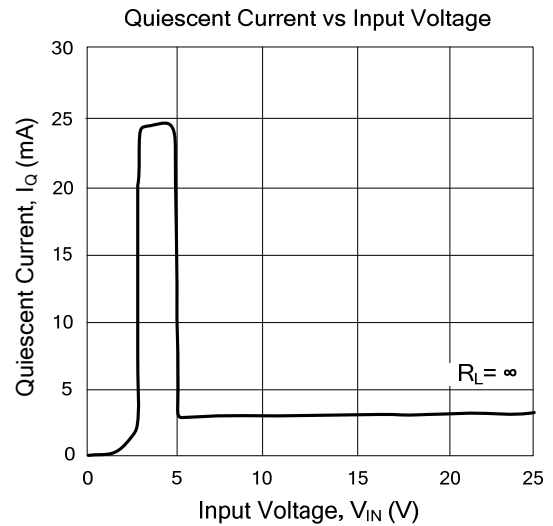
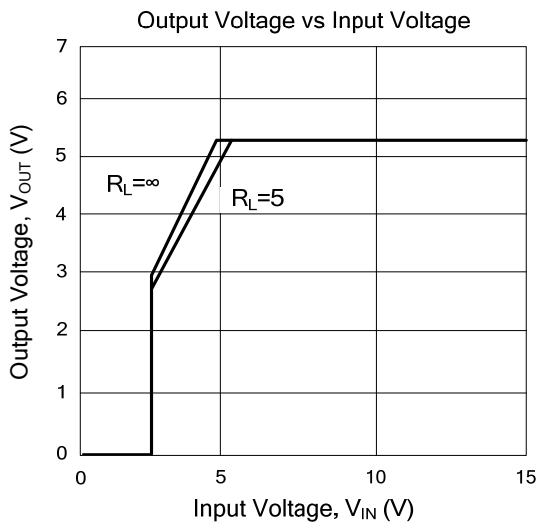

■ TYPICAL CHARACTERISTICS(Cont.)

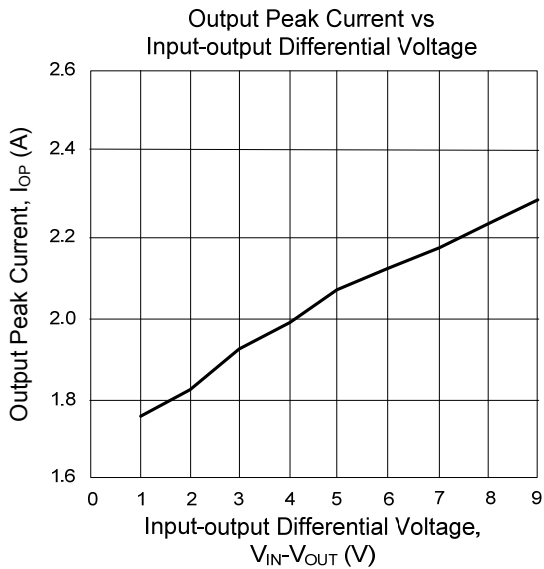
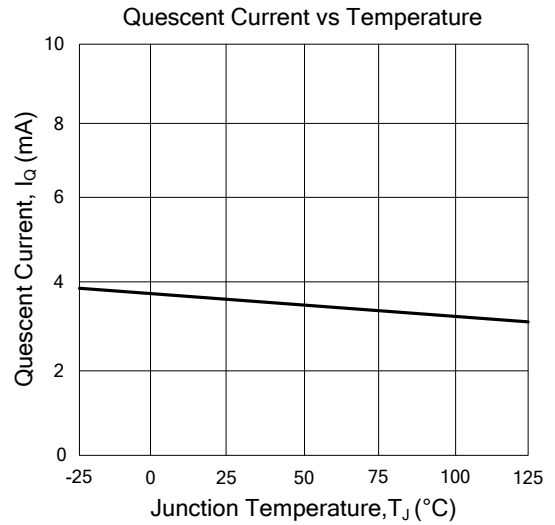
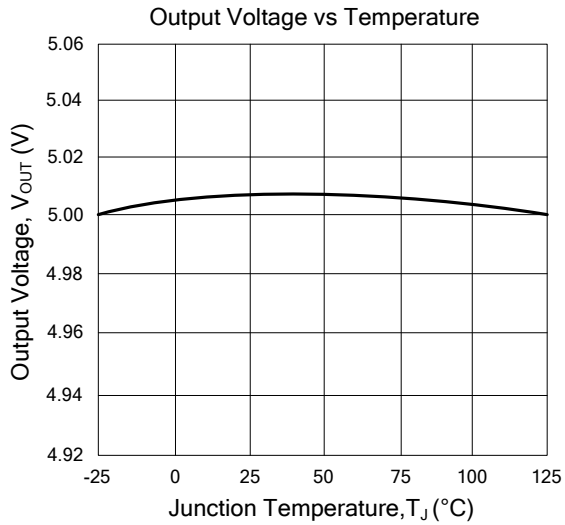

(3) 78R09

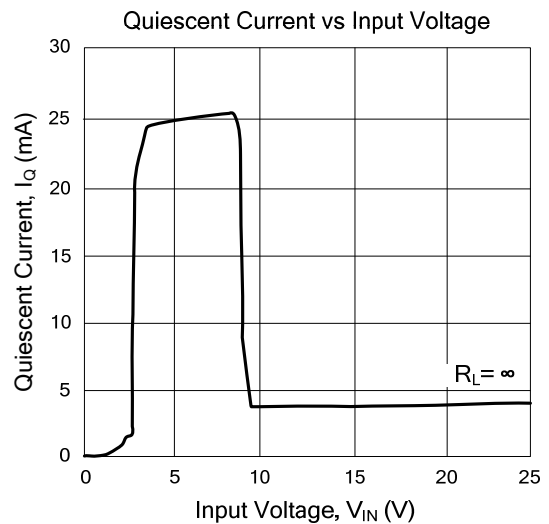
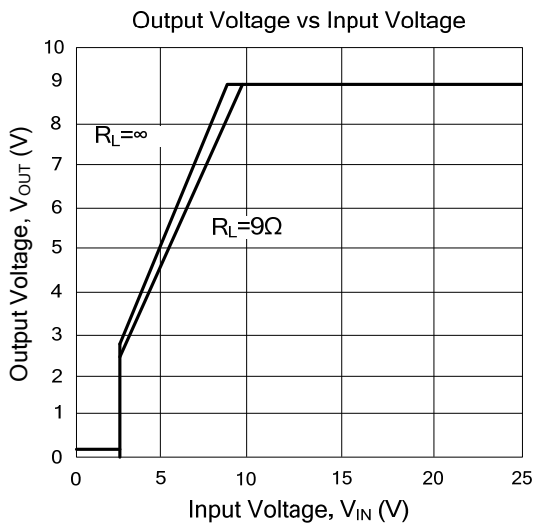

■ TYPICAL CHARACTERISTICS(Cont.)

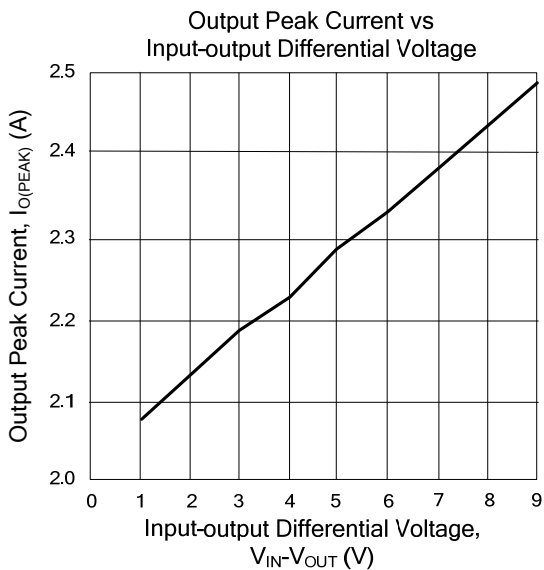
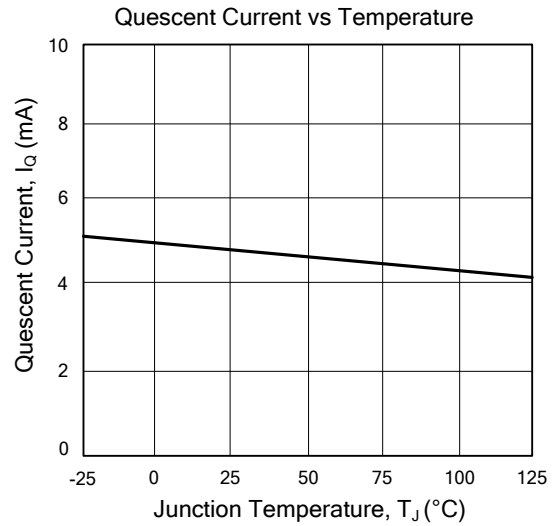
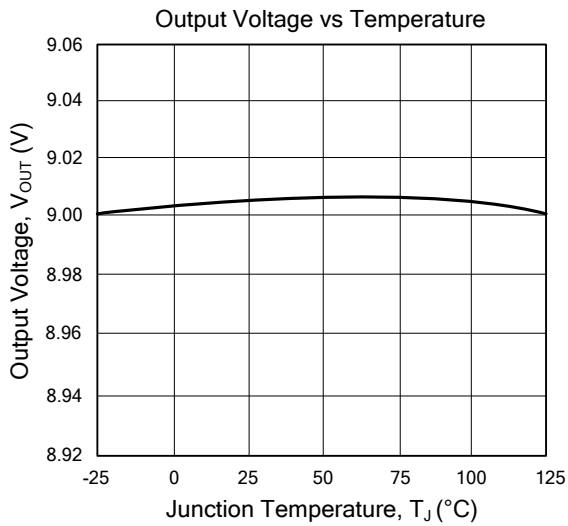
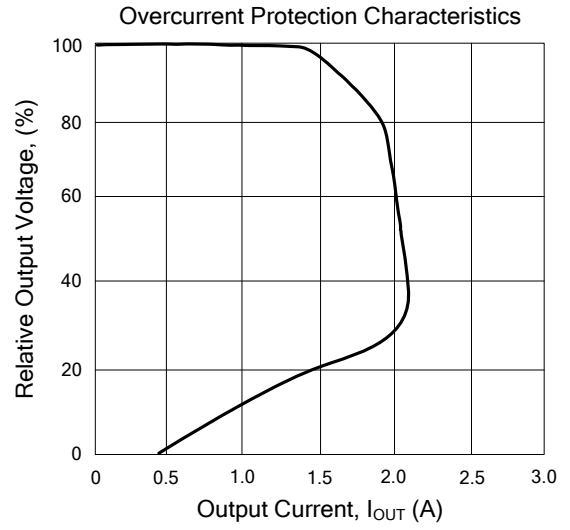
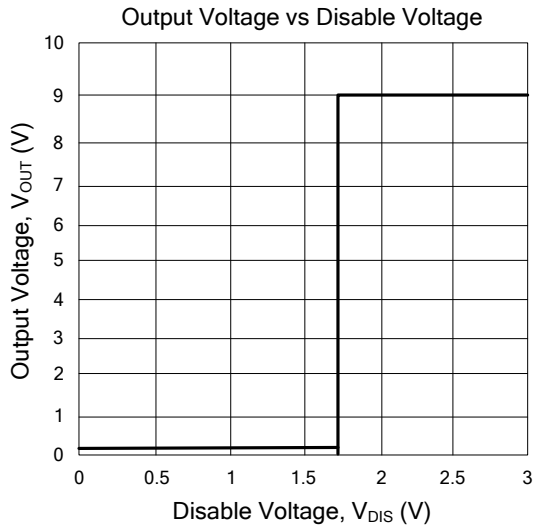

UTC assumes no responsibility for equipment failures that result from using products at values that exceed, even momentarily, rated values (such as maximum ratings, operating condition ranges, or other parameters) listed in products specifications of any and all UTC products described or contained herein. UTC products are not designed for use in life support appliances, devices or systems where malfunction of these products can be reasonably expected to result in personal injury. Reproduction in whole or in part is prohibited without the prior written consent of the copyright owner. The information presented in this document does not form part of any quotation or contract, is believed to be accurate and reliable and may be changed without notice.