



93334

LINEAR INTEGRATED CIRCUIT

HIGH ENERGY IGNITION CIRCUIT

DESCRIPTION

This device is designed to use the signal from a retractor type ignition pickup to produce a well controlled output from a power darlington output transistor.

FEATURES

- * Very Low Peripheral Component Count
- * No Critical System Resistors
- * Wide Supply Voltage Operating Range (4.0V ~ 24V)
- * Overvoltage Shutdown (30V)
- * Dwell Automatically Adjusts to Produce Optimum Stored Energy without Waste
- * Externally Adjustable Peak Current
- * Transient Protected Inputs and Outputs

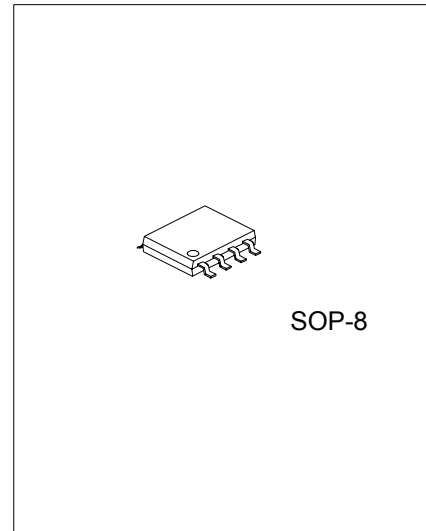

*Pb-free plating product number: 93334L

ORDERING INFORMATION

Ordering Number		Package	Packing
Normal	Lead Free Plating		
93334-S08-R	93334L-S08-R	SOP-8	Tape Reel
93334-S08-T	93334L-S08-T	SOP-8	Tube

<p>93334L-S08-R</p> <p>(1)Packing Type (2)Package Type (3)Lead Plating</p>	<p>(1) R: Tape Reel, T: Tube (2) S08: SOP-8 (3) L: Lead Free Plating, Blank: Pb/Sn</p>
--	--

發行
FOR ISSUE
JUL 17.2007
文件管理中心
UTC Doc.Control Center

■ PIN CONFIGURATION

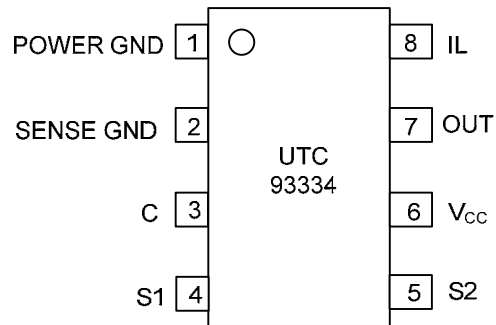

發行
FOR ISSUE
JUL 17.2007
文件管理中心
UTC Doc.Control Center

■ BLOCK DIAGRAM AND TYPICAL APPLICATION

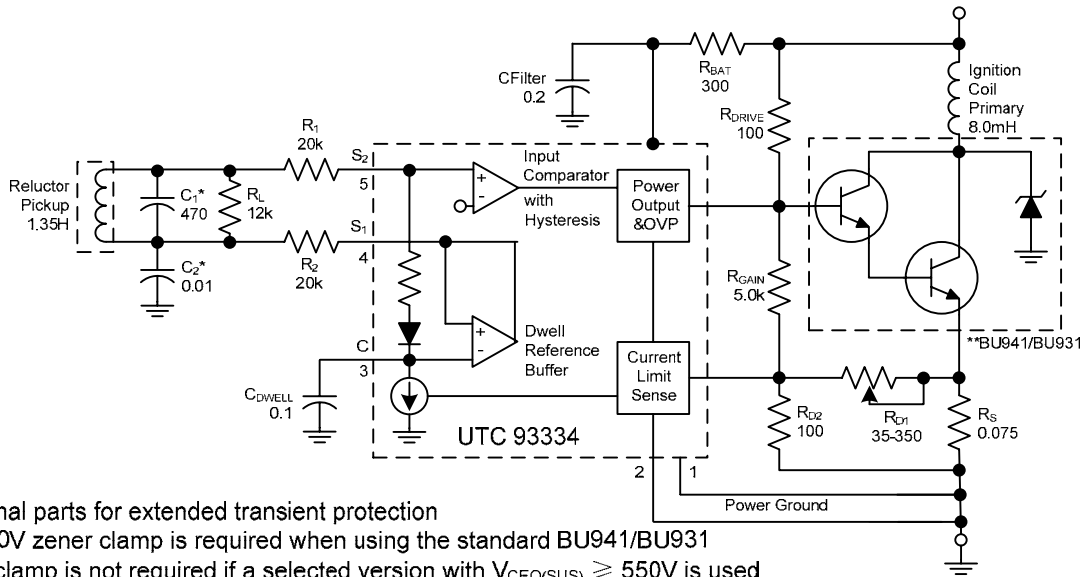

* Optional parts for extended transient protection
 ** A 350V zener clamp is required when using the standard BU941/BU931
 This clamp is not required if a selected version with $V_{CEQ(SUS)} \geq 550V$ is used

Figure 1

Component Values

Pickup	Series resistance = $800\Omega \pm 10\%$ @ 25 , inductance= $1.35H$ @ $1.0kHz$ @ $15Vrms$
Coil	Leakage $L=0.6mH$, primary $R=0.43\Omega \pm 5\%$ @ 25 , primary $L=7.5mH \sim 8.5mH$ @ $5.0A$
RL	Load resistor for pickup= $12K\Omega \pm 20\%$
R1, R2	Input buffer resistors provide additional transient protection to the already clamped inputs= $20k\Omega \pm 20\%$
C1, C2	For reduction of high frequency noise and spark transients induced in pick-up and leads; optional and non-critical
RBAT	Provides load dump protection (but small enough to allow operation at $V_{BAT}=4.0V$) = $300\Omega \pm 20\%$
CFilter	Transient filter on V_{CC} , non-critical
CDWELL	Stores reference, circuit designed for $0.1\mu F \pm 20\%$
RGAIN	R_{GAIN}/R_{D1} sets the DC gain of the current regulator = $5.0k\Omega \pm 20\%$
RD2	R_{D2}/R_{D1} set up voltage feedback from R_S
RS	Sense resistor (P_{DAG} in thick film techniques) = $0.075\Omega \pm 30\%$
RDRIVE	Low enough to supply drive to the output Darlington, high enough to keep $V_{CE(SAT)}$ of the I_C below Darlington turn-on during load dump = $100\Omega \pm 20\%$, $5.0W$
RD1	Starting with 35Ω assures less than $5.5A$, increasing as required to set $5.5A$ $R_{D1} = (I_{O(PEAK)} R_S - V_{REF}) / ((V_{REF}/R_{D2}) - (1.4/R_{GAIN})) - (\approx 100\Omega)$

發 行
FOR ISSUE
JUL 17.2007
文件管理中心
UTC Doc.Control Center

■ ABSOLUTE MAXIMUM RATINGS

PARAMETER	SYMBOL	RATINGS	UNIT
Power Supply Voltage-Steady State Transient 300ms or less	V_{CC}	24	V
		90	
Output Sink Current-Steady State Transient 300ms or less	$I_{OUT(SINK)}$	300	mA
		1.0	A
Power Dissipation Derate above 25°C	P_D	1.05	W
		12	mW/°C
Junction Temperature	T_J	+125	°C
Operating Temperature	T_{OPR}	-40~+125	°C
Storage Temperature	T_{STG}	-40 ~ 150	°C

Note: Absolute maximum ratings are those values beyond which the device could be permanently damaged. Absolute maximum ratings are stress ratings only and functional device operation is not implied.

■ ELECTRICAL CHARACTERISTICS ($V_{CC} = 13.2V_{DC}$, circuit of Figure 3, unless otherwise specified)

PARAMETER	SYMBOL	TEST CONDITIONS	MIN	TYP	MAX	UNIT
Internal Supply Voltage, Pin 6	V_{CC}	$V_{BAT} = 4.0V_{DC}$		3.5		V_{DC}
		$V_{BAT} = 8.0V_{DC}$		7.2		
		$V_{BAT} = 12.0V_{DC}$		10.4		
		$V_{BAT} = 14.0V_{DC}$		11.8		
Ignition Coil Current Peak, Cranking RPM 2.0Hz ~ 27Hz	I_{PEAK}	$V_{BAT} = 4.0V_{DC}$	3.0	3.4		A_{PEAK}
		$V_{BAT} = 6.0V_{DC}$	4.0	5.2		
		$V_{BAT} = 8.0V_{DC}$	4.6	5.3		
		$V_{BAT} = 10.0V_{DC}$	5.1	5.4		
Ignition Coil Current Peak, Normal RPM	I_{PEAK}	F=33Hz	5.1	5.5		A_{PEAK}
		F=133Hz	5.1	5.5		
		F=200Hz	4.2	5.4		
		F=267Hz	3.4	4.4		
		F=333Hz	2.7	3.4		
Ignition Coil On-Time, Normal RPM Range	T_{ON}	F=33Hz		7.5	14.0	ms
		F=133Hz		5.0	5.9	
		F=200Hz		4.0	4.6	
		F=267Hz		3.0	3.6	
		F=333Hz		2.3	2.8	
Shutdown Voltage	V_{BAT}		25	30	35	V_{DC}
Input Threshold (Static Test)	V_{THR}	Turn-on		360		mV V_{DC}
		Turn-off		90		
Input Threshold Hysteresis	V_{HYS}		75			mV V_{DC}
Input Threshold (Active Operation)	V_{THR}	Turn-on		1.8		V_{DC}
		Turn-off		1.5		
Total Circuit Lag from t_s (Figure 1) until Ignition Coil Current Falls to 10%				60	120	μs
Ignition Coil Current Fall Time (90% ~ 10%)				4.0		μs
Saturation Voltage IC Output (Pin 7) ($R_{DRIVE} = 100\Omega$)	$V_{CE(SAT)}$	$V_{BAT} = 10V_{DC}$		120		mV V_{DC}
		$V_{BAT} = 30V_{DC}$		280		
		$V_{BAT} = 50V_{DC}$		540		
Current Limit Reference, Pin 8	V_{REF}			120	160	mV V_{DC}

發 行
F O R 120 I S 16 U 19
JUL 17.2007
文件管理中心
UTC Doc.Control Center

■ IGNITION COIL CURRENT VS. FREQUENCY / PERIOD

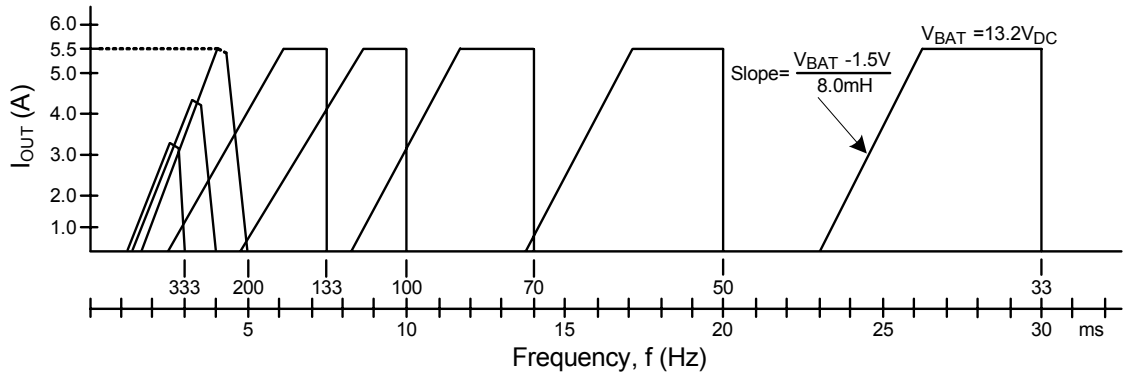

UTC assumes no responsibility for equipment failures that result from using products at values that exceed, even momentarily, rated values (such as maximum ratings, operating condition ranges, or other parameters) listed in products specifications of any and all UTC products described or contained herein. UTC products are not designed for use in life support appliances, devices or systems where malfunction of these products can be reasonably expected to result in personal injury. Reproduction in whole or in part is prohibited without the prior written consent of the copyright owner. The information presented in this document does not form part of any quotation or contract, is believed to be accurate and reliable and may be changed without notice.