



L5101

LINEAR INTEGRATED CIRCUIT

WHITE LED STEP-UP CONVERTER

DESCRIPTION

The UTC **L5101** is a constant current step-up PWM DC/DC converter optimized to drive white LEDs. It can drive LEDs in series with a Li-Ion cell.

The switching frequency of the internal NPN is up to 1.2MHz. High frequency allows the use of tiny external components and the current setting resistor has minimum power dissipation for the low feedback voltage of 95mV. The built-in OVP prevents the UTC **L5101** damage from the open load condition. Series connection of LEDs provides identical LED currents which contributes to uniform brightness, saving the use of ballast resistors.

The UTC **L5101** is universally used in cellular phones, PDAs , DSCs, handheld devices, and white LED display backlighting.

FEATURES

- * Open Circuit and Over Voltage Protection
- * High Efficiency: 86% Typical
- * Switching Frequency: 1.2MHz
- * Supply Current is 1.0mA
- * Matches LED Current
- * Requires Tiny Inductor and Capacitors
- * Halogen Free

ORDERING INFORMATION

Ordering Number	Package	Packing
L5101G-AG6-R	SOT-26	Tape Reel

L5101G-AG6-R		
(1)Packing Type	(1) R: Tape Reel	
(2)Package Type	(2) AG6: SOT-26	
(3)Halogen Free	(3) G: Halogen Free	

MARKING

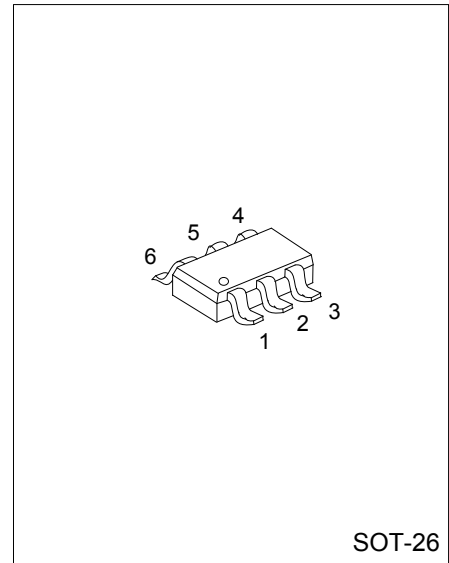
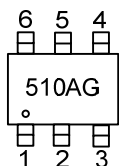

SOT-26

■ PIN CONFIGURATION

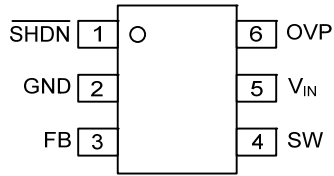

■ PIN DESCRIPTION

PIN NO.	PIN NAME	SYMBOL	DESCRIPTION
1	Shutdown	$\overline{\text{SHDN}}$	Tie to higher than 1.5V to enable device, 0.3V or less to disable device.
2	Ground	GND	
3	Feedback	FB	Reference voltage is 95mV. Connect cathode of lowest LED and resistor here. Calculation formula: $R_{\text{FB}}=95\text{mV}/I_{\text{LED}}$
4	Switch	SW	Connect inductor/diode here. Minimize trace area at this pin to reduce EMI.
5	Power input	V_{IN}	Bypass V_{IN} to GND with a capacitor sitting as close to V_{IN} as possible.
6	Over voltage protection	OVP	The internal NPN will turn off when $V_{\text{OUT}} > 27\text{V}$.

■ BLOCK DIAGRAM

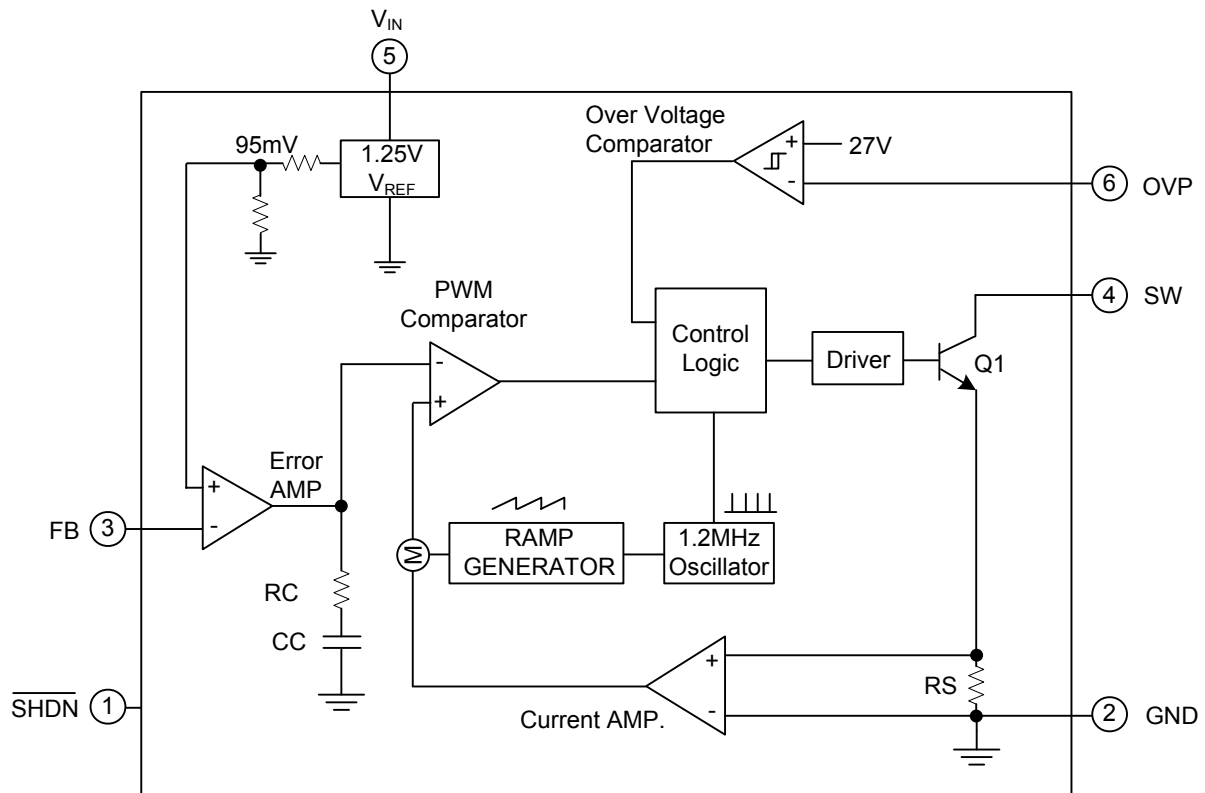

■ ABSOLUTE MAXIMUM RATING

PARAMETER	SYMBOL	RATINGS	UNIT
Input Voltage	V_{IN}	6	V
SW Voltage	V_{SW}	33	V
FB Voltage	V_{FB}	6	V
SHDN Voltage	$V_{\overline{SHDN}}$	6	V
OVP Voltage	V_{OVP}	34	V
Junction Temperature	T_J	+125	°C
Operating Temperature Range	T_{OPR}	0 ~ +70	°C
Storage Temperature Range	T_{STG}	-40 ~ +150	°C

Note: Absolute maximum ratings are those values beyond which the device could be permanently damaged. Absolute maximum ratings are stress ratings only and functional device operation is not implied.

■ ELECTRICAL CHARACTERISTICS ($V_{\overline{SHDN}}=3V$, $V_{IN}=3V$, $T_a=25^\circ C$, unless otherwise specified.)

PARAMETER	SYMBOL	TEST CONDITIONS	MIN	TYP	MAX	UNIT
Operating Voltage	V_{IN}		2.5		5.5	V
Supply Current	I_{IN}	Switching		2	5	mA
		Non switching		1	2	
		$V_{\overline{SHDN}}=0V$		0.1	1.0	μA
ERROR AMPLIFIER						
Feedback Voltage	V_{FB}		85	95	105	mV
FB Input Bias Current	I_{FB}	$V_{FB}=95mV$		100		nA
OSCILLATOR						
Switching Frequency	f_{SW}		0.8	1.2	1.6	MHz
Maximum Duty Cycle	DC		85	90		%
POWER SWITCH						
SW ON Resistance	$R_{ON(SW)}$			1.4	5	Ω
Switch Leakage Current	$I_{LEAK(SW)}$	$V_{SW}=33V$		0.1	1	μA
CONTROL INPUT						
Shutdown Voltage	High	$V_{IH(\overline{SHDN})}$	ON	1.5		V
	Low	$V_{IL(\overline{SHDN})}$	OFF		0.3	V
OVER VOLTAGE PROTECTION						
OVP Input Resistance	$R_{IN(OVP)}$		0.6	1.2	1.8	M Ω
OVP Threshold	$V_{THR(OVP)}$	1V Hysteresis typical	22	27	32	V

■ TEST CIRCUIT

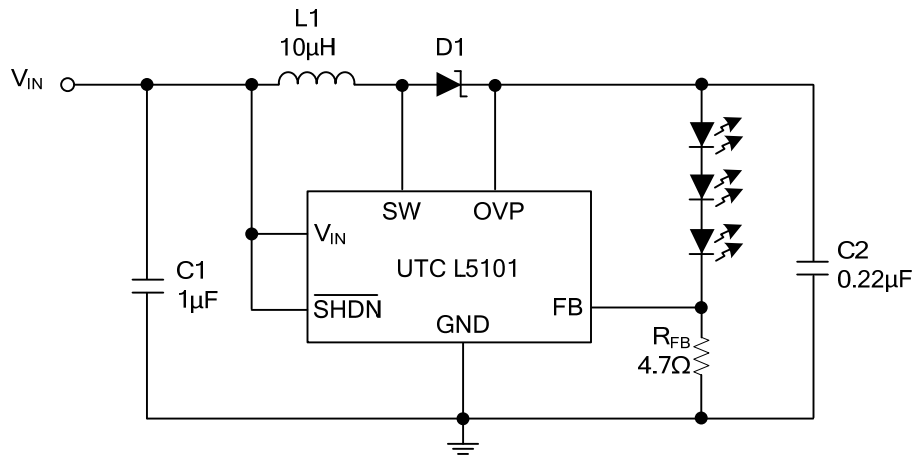

Fig.1 Test Circuit

APPLICATION INFORMATION

Recommended Component Selection

- * Inductor Selection: A 10 μ H inductor is recommended for most applications.
- * Capacitor Selection: The small size of ceramic capacitor makes it ideal for UTC **L5101** applications, X5R and X7R types are recommended because of their stable characteristics, 1 μ F input capacitor with 1 μ F output capacitor is sufficient for most UTC **L5101** applications.
- * Diode Selection: Schottky diode, for its low forward voltage drop and fast reverse recovery, is an ideal choice for the UTC **L5101** diode. A Schottky diode rated 100mA to 200mA is sufficient for most UTC **L5101** applications, and the higher current rating usually have larger diode capacitance which can cause significant switching losses at the 1.2MHz switching frequency.

LED Current Control

A feedback resistor (precision 1% recommended) as feedback resistor control the LED current. (R_{FB} in Figure 1)

* Feedback reference voltage: 95mV.

* LED current is $95\text{mV}/R_{FB}$.

* The formula for R_{FB} selection: $R_{FB}=95\text{mV}/I_{LED}$

Open-Circuit Protection

The OVP(Over Voltage Protection) protects the voltage lower than its maximum level under the open circuit condition, which is caused by the failure or disconnection of the LEDs. The above undesired fault conditions will cause the feedback voltage falling to 0V, then the UTC L5101 increases duty circle resulting in a high voltage in SW pin.

Dimming Control

There are three different ways of dimming control circuits as follows:

1. Using a PWM signal

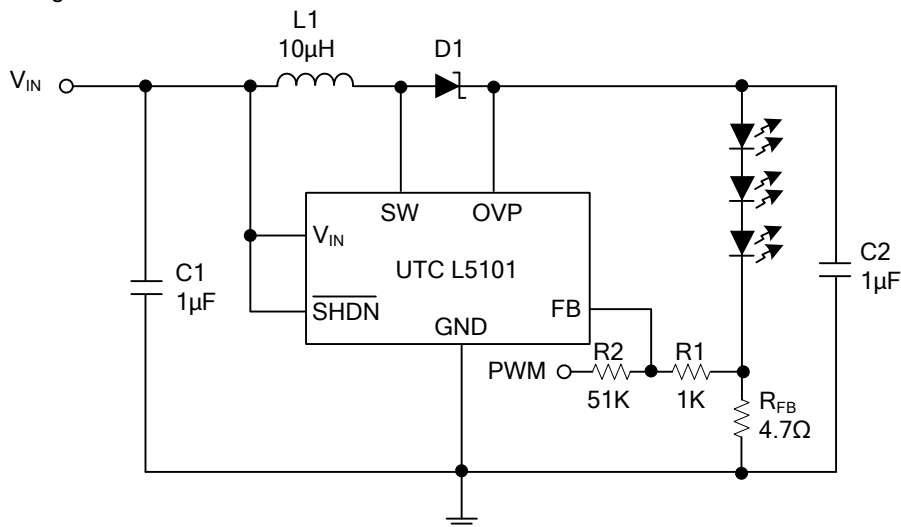

Fig. 2 Dimming Control Using a PWM Signal

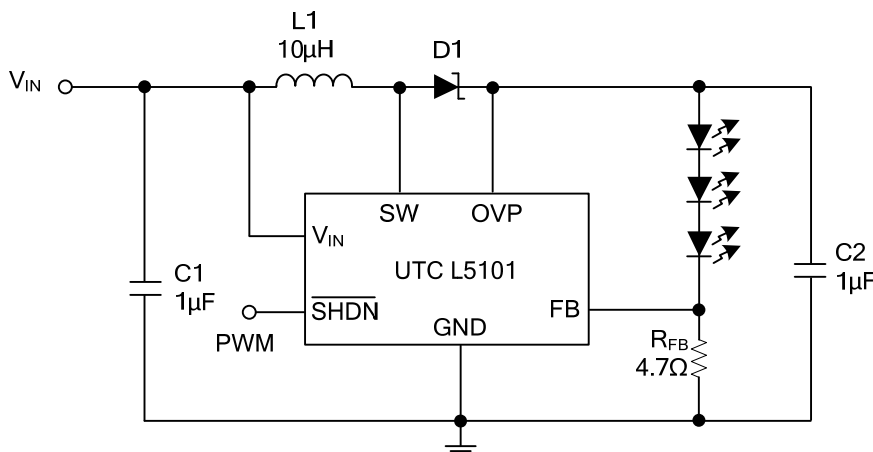

Fig. 3 Dimming Control with a PWM Signal

APPLICATION INFORMATION(Cont.)

2. Using a DC Voltage

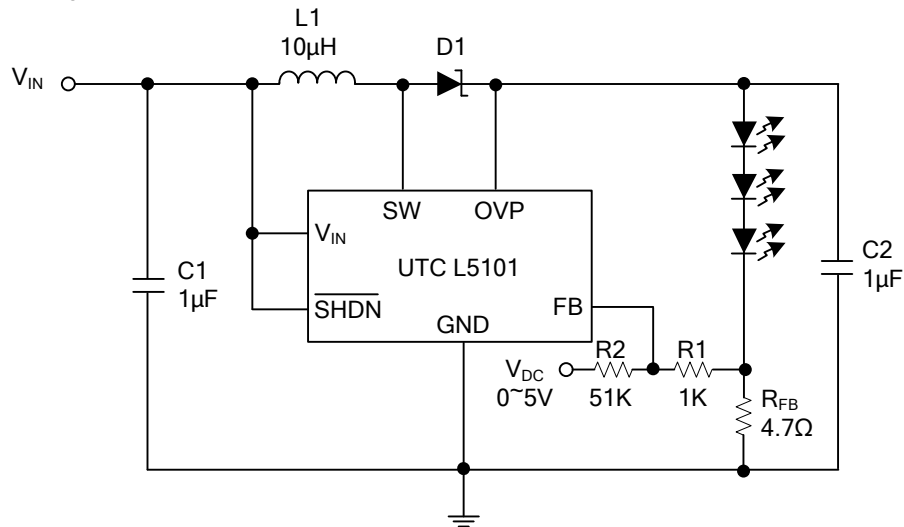

Fig. 4 Dimming Control Using a DC Voltage

3. Using a Filtered PWM Signal

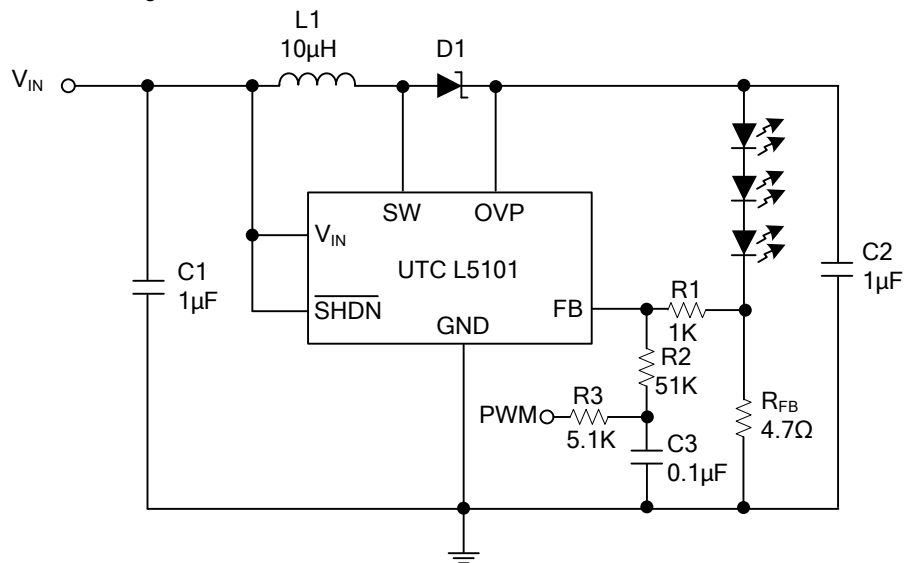

Fig. 5 Dimming Control Using a Filter PWM Signal

■ TYPICAL APPLICATION CIRCUIT

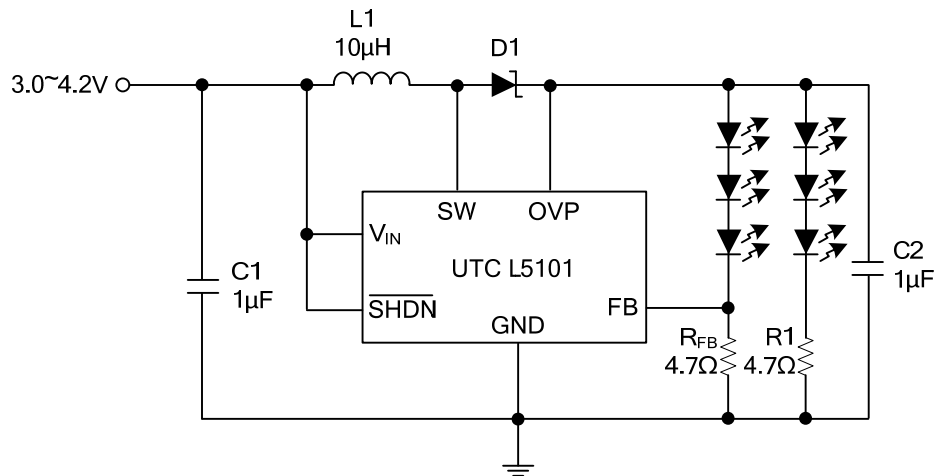
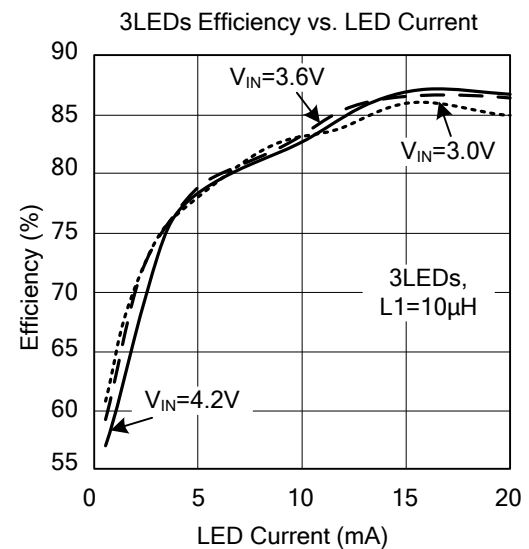
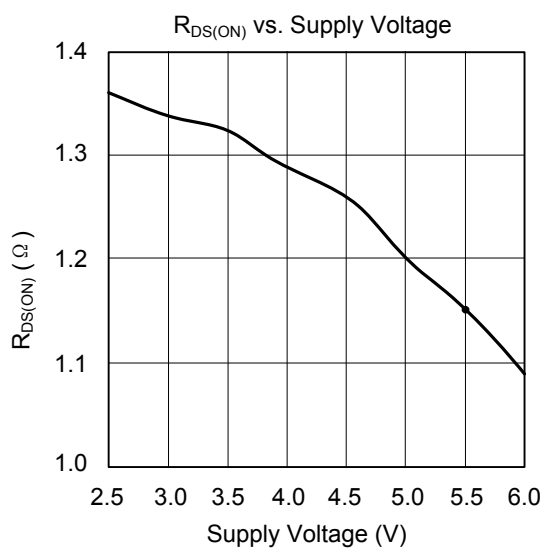
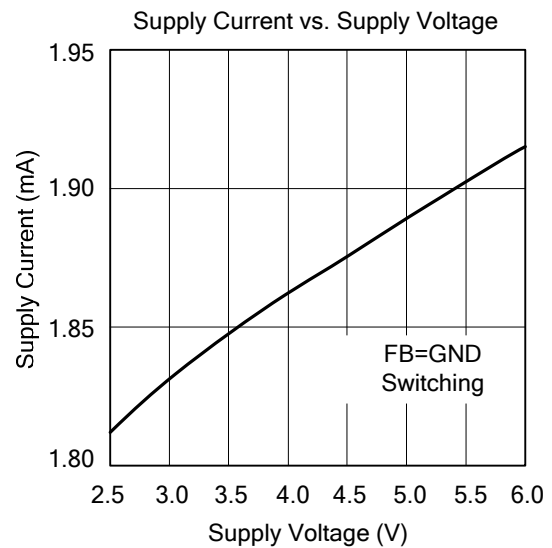
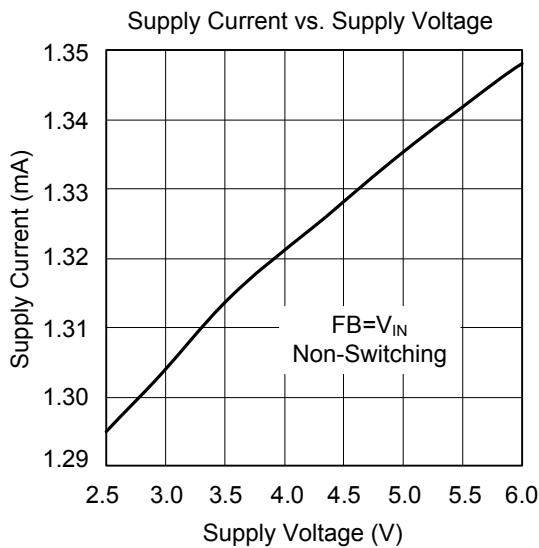
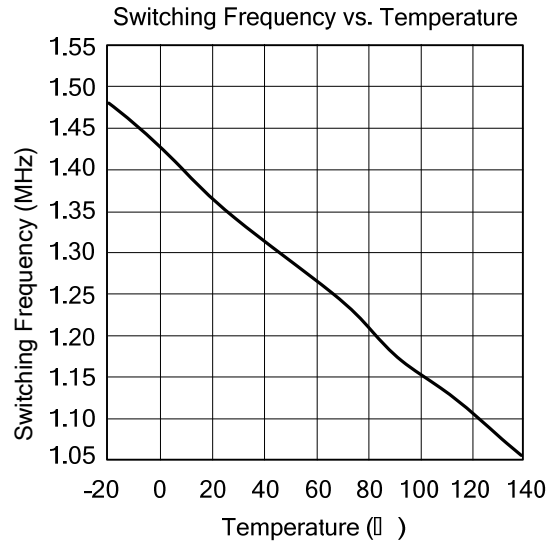
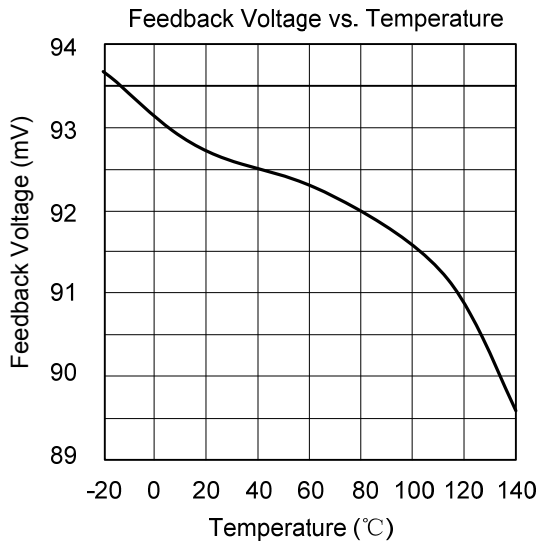
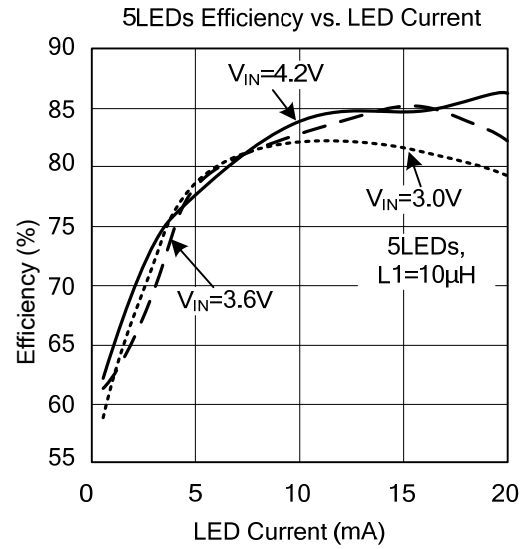
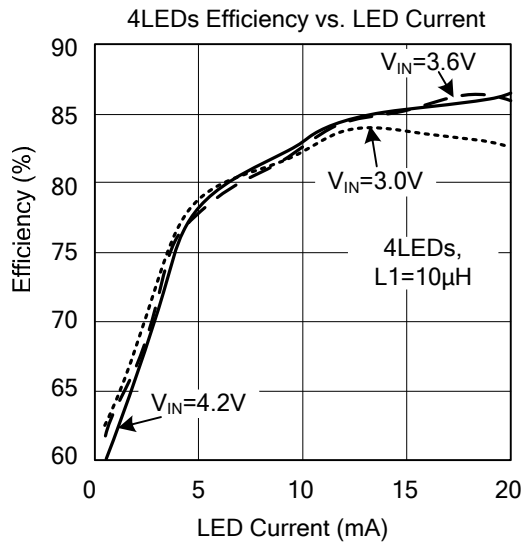

Fig. 6 Six White LEDs Application in Li-Ion Battery

TYPICAL CHARACTERISTICS



TYPICAL CHARACTERISTICS



UTC assumes no responsibility for equipment failures that result from using products at values that exceed, even momentarily, rated values (such as maximum ratings, operating condition ranges, or other parameters) listed in products specifications of any and all UTC products described or contained herein. UTC products are not designed for use in life support appliances, devices or systems where malfunction of these products can be reasonably expected to result in personal injury. Reproduction in whole or in part is prohibited without the prior written consent of the copyright owner. The information presented in this document does not form part of any quotation or contract, is believed to be accurate and reliable and may be changed without notice.