

UTC LT1304/LT1304-3.3V/LT1304-5.0V LINEAR INTEGRATED CIRCUIT

MICROPOWER DC/DC CONVERTERS WITH LOW-BATTERY DETECTOR ACTIVE IN SHUTDOWN

DESCRIPTION

The UTC LT1304 is a micropower step-up DC/DC converter ideal for use in small, low voltage, battery-operated systems. The devices operate from a wide input supply range of 1.5V to 8V.

The UTC LT1304-3.3 and LT1304-5.0 generate regulated outputs of 3.3V and 5V and the adjustable LT1304 can deliver output voltages up to 25V. Quiescent current, 120 μ A in active mode, decreases to just 10 μ A in shutdown with the low-battery detector still active. Peak switch current, internally set at 1A, can be reduced by adding a single resistor from the ILIM pin to ground. The high speed operation of the UTC LT1304 allows the use of small, surface-mountable inductors and capacitors.

FEATURES

- *5V at 200mA from two cells.
- *10 μ A quiescent current in shutdown.
- *Operates with V_{IN} as low as 1.5V
- *Low battery detector active in shutdown
- *Low switch V_{CESAT} : 370mV at 1A typical.
- *120 μ A quiescent current in active mode.
- *Switching frequency up to 300kHz
- *Programmable peak current with one resistor.

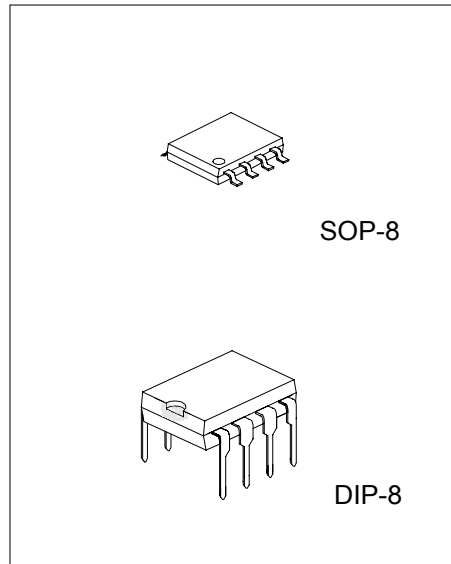

APPLICATIONS

- *2-, 3-, or 4-cell to 5V or 3.3V step-up
- *Portable instruments
- *Bar code scanners
- *Palmtop computers
- *Diagnostic medical instrumentation.
- *Personal data communicators/computers.

PIN CONFIGURATION

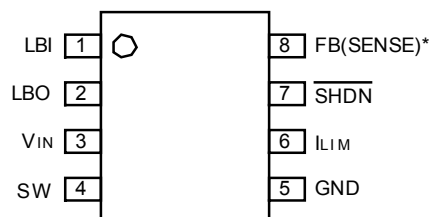

UTC LT1304/LT1304-3.3V/LT1304-5.0V LINEAR INTEGRATED CIRCUIT

ABSOLUTE MAXIMUM RATINGS

PARAMETER	SYMBOL	RATING	UNIT
Input Voltage	V _{IN}	8	V
SW Voltage		-0.4 ~ +25	V
FB Voltage(LT1304)		V _{IN} +0.3	V
I _{LIM} Voltage(LT1304-3.3/LT1304-5.0)		5	V
SHDN Voltage		6	V
LBI Voltage		V _{IN}	V
LBO Voltage		8	V
Maximum Power Dissipation	P _D	500	mW
Junction Temperature	T _j	125	°C
Operating Temperature Range	Topr	0 ~ 70	°C
Storage Temperature Range	Tstg	-65 ~ +150	°C
Lead Temperature (soldering, 10sec)		300	°C

ELECTRICAL CHARACTERISTICS (V_{IN}=2V, V_{SHDN}=2V Unless otherwise noted.)

PARAMETER	TEST CONDITIONS	MIN	TYP	MAX	UNIT
Minimum Operating Voltage	*		1.5	1.65	V
Operating Voltage Range	*			8	V
Quiescent Current	* V _{SHDN} =2V, Not switching		120	200	μA
Quiescent Current In Shutdown	* V _{SHDN} =0V, V _{IN} =2V		7	15	μA
	* V _{SHDN} =0V, V _{IN} =5V		27	50	μA
Comparator Trip Point	*	1.22	1.24	1.26	V
FB Pin Bias Current	*		10	25	nA
Sense Pin Leakage in Shutdown	* V _{SHDN} =0V, Fixed Output Versions		0.002	1	μA
Line Regulation	* 1.8V ≤ V _{IN} ≤ 8V		0.04	0.15	%/V
LBI Input Threshold	* Falling Edge	1.10	1.17	1.25	V
LBI Bias Current	*		6	20	nA
LBI Input Hysteresis	*		35	65	mV
LBO Output Voltage Low	* I _{SINK} =500μA		0.2	0.4	V
LBO Output Leakage Current	* LBI=1.5V, LBO=5V		0.01	0.1	μA
SHDN Input Voltage High	*	1.4			V
SHDN Input Voltage Low	*			0.4	V
SHDN Pin Bias Current	* V _{SHDN} =5V		5	8	μA
	* V _{SHDN} =0V	-5	-2		μA
Switching Off Time	*	1	1.5	2	μs
Switch On Time	* Current Limit Not Asserted	4	6	8	μs
Maximum Duty Cycle	* Current Limit Not Asserted	76	80	88	%
Peak Switch Current	I _{LIM} Pin Open, V _{IN} =5V	0.8	1	1.2	A
	20K from I _{LIM} to GND		500		mA
Switch Saturation Voltage	I _{sw} =1A		0.37		V
	* I _{sw} =700mA		0.26	0.35	V

UTC UNISONIC TECHNOLOGIES CO., LTD. 2

UTC LT1304/LT1304-3.3V/LT1304-5.0V LINEAR INTEGRATED CIRCUIT

PARAMETER	TEST CONDITIONS	MIN	TYP	MAX	UNIT
Switch Leakage	Switch off, $V_{sw}=5V$		0.01	7	μA

The * denotes specifications which apply over the 0°C to 70°C operating temperature range.

PIN FUNCTIONS

PIN No.	SYMBOL	DESCRIPTION
1	LBI	Low Battery Detector Input. When voltage on this pin is less than 1.17V, detector output is low
2	LBO	Low Battery Detector Output. Open collector can sink up to 500 μA . Low battery detector remains active when device is shut down.
3	V_{IN}	Input Supply. Must be bypassed close (<0.2") to the pin. See required layout in the Typical Applications
4	SW	Collector of Power NPN. Keep copper traces on this pin short and direct to minimize RFI
5	GND	Device Ground. Must be low impedance; solder directly to ground plane
6	I_{LIM}	Current Limit Set Pin. Float for 1A peak switch current; a resistor to ground will lower peak current
7	SHDN	Shutdown Input. When low, switching regulator is turned off. The low-battery detector remains active. The SHDN input should not be left floating. If SHDN is not used, tie the pin to V_{IN}
8	FB/SENSE	On the LT1304 (adjustable) this pin goes to the comparator input. On the fixed-output versions, the pin connects to the resistor divider which sets output voltage. The divider is disconnected from the pin during shutdown.

TYPICAL APPLICATION

2-Cell to 5V Step-Up Converter with Low-Battery Detect

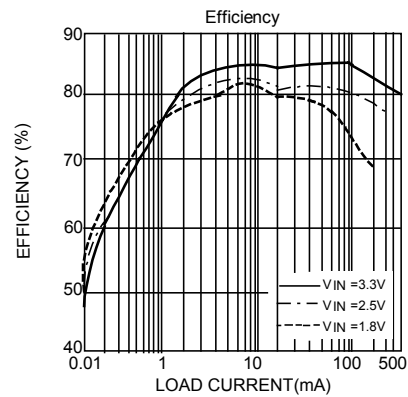
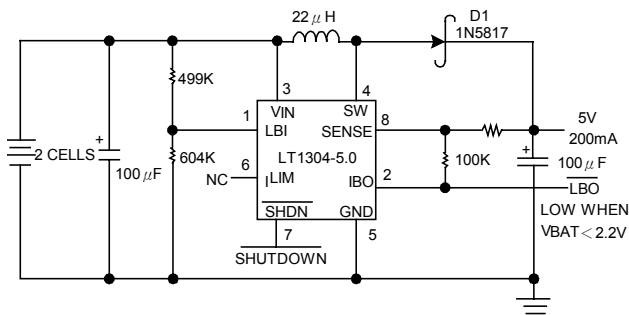

UTC LT1304/LT1304-3.3V/LT1304-5.0V LINEAR INTEGRATED CIRCUIT

TYPICAL PERFORMANCE CHARACTERISTICS

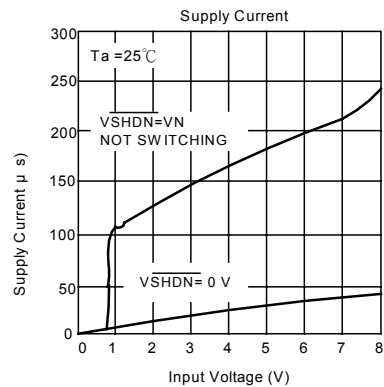
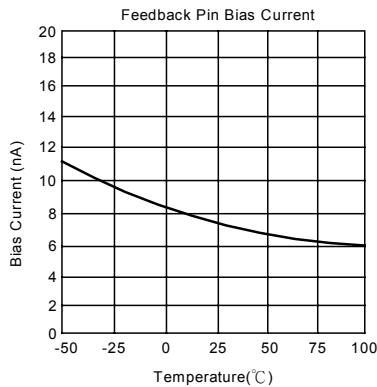
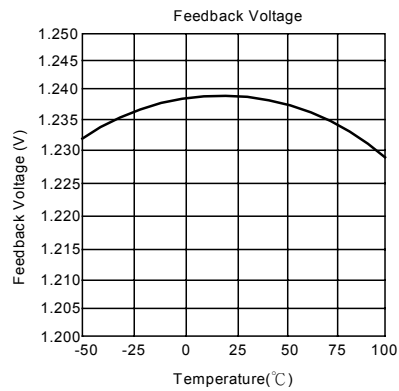
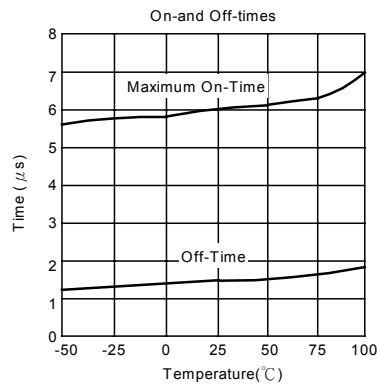
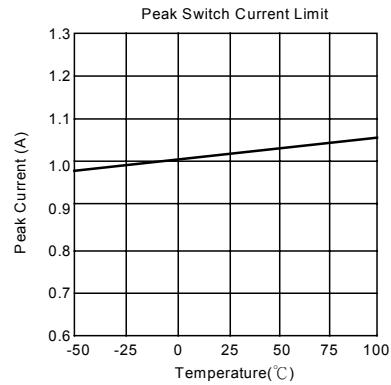
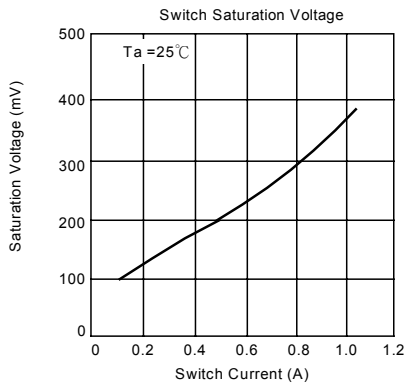

UTC LT1304/LT1304-3.3V/LT1304-5.0V LINEAR INTEGRATED CIRCUIT

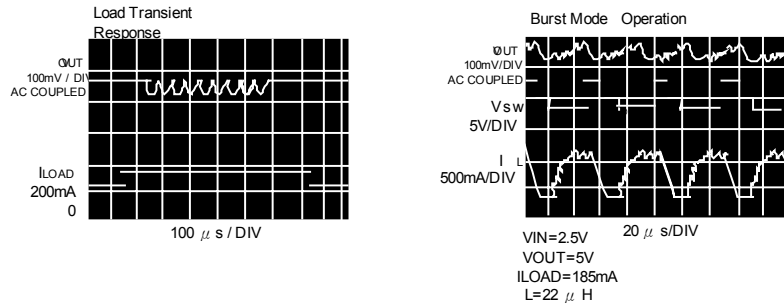

BLOCK DIAGRAMS

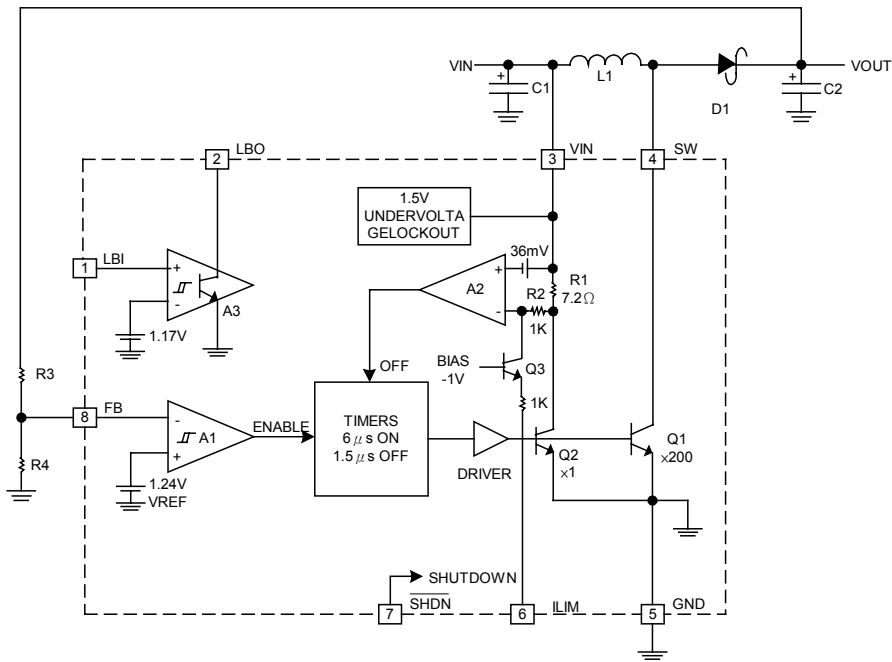

Figure 1. LT1304 Block Diagram. Independent Low-Battery Detector A3 Remains Alive When Device Is in Shutdown

UTC LT1304/LT1304-3.3V/LT1304-5.0V LINEAR INTEGRATED CIRCUIT

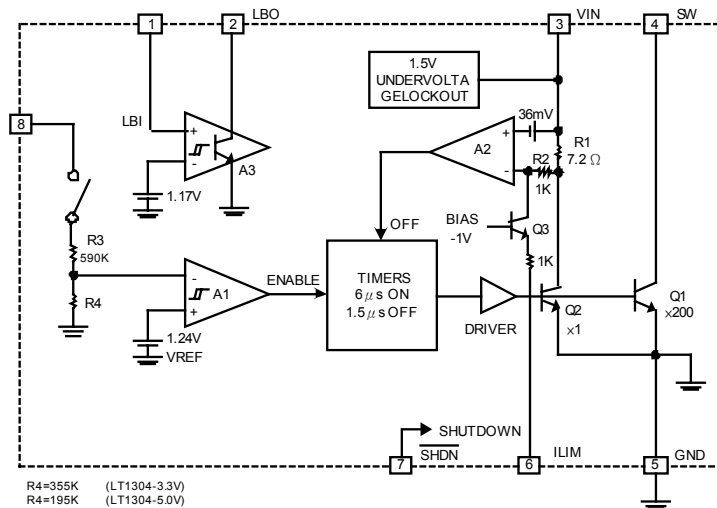

Figure 2. LT1304-3.3/LT1304-5.0 Block Diagram

OPERATION

The LT1304 operation can best be understood by examining the block diagram in Figure 1. Comparator A1 monitors the output voltage via resistor divider string R3/R4 at the FB pin. When V_{FB} is higher than the 1.24V reference, A2 and the timers are turned off. Only the reference, A1 and A3 consume current, typically 120 μ A. As V_{FB} drops below 1.24V plus A1's hysteresis (about 6mV), A1 enables the rest of the circuit. Power switch Q1 is then cycled on for 6 μ s, or until current comparator A2 turns off the ON timer, whichever comes first. Off-time is fixed at approximately 1.5 μ s. Q1's switching cause current to alternately build up in inductor L1 and discharge into output capacitor C2 via D1, increasing the output voltage. As V_{FB} increases enough to overcome C1's hysteresis, switching action ceases. C2 is left to supply current to the load until V_{OUT} decreases enough to force A1's output high, and the entire cycle repeats. If switch current reaches 1A, causing A2 to trip, switch ON time is reduced. This allows continuous mode operation during bursts. A2 monitors the voltage across 7.2 Ω resistor R1, which is directly related to the switch current. Q2's collector current is set by the emitter-area ratio to 0.5% of Q1's collector current. R1's voltage drop exceeds 36mV, corresponding to 1A switch current, A2's output goes high, truncating the ON time part of the switch cycle. The 1A peak current can be reduced by tying a resistor between the ILIM pin and ground, causing a voltage drop to appear across R2. The drop offsets some of the 36mV reference voltage, lowering peak current. A 22K resistor limits current to approximately 550mA. A capacitor connected between ILIM and ground provides soft start. Shutdown is accomplished by grounding the SHDN pin.

The low-battery detector A3 has its own 1.17V reference and is always on. The open collector output device can sink up to 500 μ A. Approximately 35mV of hysteresis is built into A3 to reduce "buzzing" as the battery voltage reaches the trip level.

INDUCTOR SELECTION

Inductors used with the LT1304 must be capable of handling the worst-case peak switch current of 1.2A without saturating. Open flux rod or drum core units may be biased into saturation by 20% with only a small reduction in efficiency. For the majority of 2-cell or 3-cell input LT1304 applications, a 22 μ H or 20 μ H inductor such as the Sumida CD54-220 (drum) or Coiltronics CTX20-1 (toroid) will suffice. If switch current is reduced using the ILIM pin, smaller inductors such as the Sumida CD43 series or Coilcraft DO1608 series can be used. Minimizing

UTC LT1304/LT1304-3.3V/LT1304-5.0V

LINEAR INTEGRATED CIRCUIT

DCR is important for best efficiency. Ideally, the inductor DCR should be less than 0.05W, although the physical size of such an inductor makes its use prohibitive in many space conscious applications. If EMI is a concern, such as when sensitive analog circuitry is present, a toroidal inductor such as the Coiltronics CTX20-1 is suggested.

A special case exists where the V_{OUT}/V_{IN} differential is high, such as a 2V to 12V boost converter. If the required duty cycle for continuous mode operation is higher than the LT1304 can provide, the converter must be designed for discontinuous operation. This means that the inductor current decreases to zero during the switch OFF time. For a simple step-up (boost) converter, duty cycle can be calculated by the following formula:

$$DC = 1 - [(V_{IN} - V_{SAT}) / (V_{OUT} + V_D)]$$

where,

V_{IN} = Minimum input voltage

V_{SAT} = Switch saturation voltage (0.3V)

V_{OUT} = Output voltage

V_D = Diode forward voltage (0.4V)

If the calculated duty cycle exceeds the minimum LT1304 duty cycle of 76%, the converter should be designed for discontinuous mode operation. The inductance must be low enough so that current in the inductor reaches the peak current in a single cycle. Inductor value can be calculated by:

$$L = (V_{IN} - V_{SAT})(t_{ON}/1A)$$

where,

t_{ON} = Minimum on-time of LT1304 (4 μ s)

One advantage of discontinuous mode operation is that inductor values are usually quite low so very small units can be used. Ripple current is higher than with continuous mode designs and efficiency will be somewhat less.

Capacitor Selection

Low ESR (Equivalent Series Resistance) capacitors should be used at the output of the LT1304 to minimize output ripple voltage. High quality input bypassing is also required. For surface mount applications AVX TPS series tantalum capacitors are recommended. These have been specifically designed for switch mode power supplies and have low ESR along with high surge current ratings. A 100 μ F, 10V AVX TPS surface mount capacitor typically limits output ripple voltage to 70mV when stepping up from 2V to 5V at a 200mA load. For through hole applications Sanyo OS-CON capacitors offer extremely low ESR in a small package size. Again, if peak switch current is reduced using the ILIM pin, capacitor requirements can be eased and smaller, higher ESR units can be used.

Diode Selection

Best performance is obtained with a Schottky rectifier such as the 1N5818. Motorola makes the MBR5130L Schottky which is slightly better than the 1N5818 and comes in a surface mount package. For lower switch currents, the MBR0530 is recommended. It comes in a very small SOD-123 package. Multiple 1N4148s in parallel can be used in a pinch, although efficiency will suffer.

ILIM Function

The LT1304's current limit (ILIM) pin can be used for soft start. Upon start-up, the LT1304 will draw maximum current (about 1A) from the supply to charge the output capacitor. Figure 3 shows V_{OUT} and V_{IN} waveforms as the device is turned on. The high current flow can create IR drops along supply and ground lines or cause the input supply to drop out momentarily. By adding R1 and C1 as shown in Figure 4, the switch current is initially limited to well under 1A as detailed in Figure 5. Current flowing into C1 from R1 and the ILIM pin will eventually charge C1 and R1 effectively takes C1 out of the circuit. R1 also provides a discharge path for C1 when SHUTDOWN is brought low for turn-off.

UTC LT1304/LT1304-3.3V/LT1304-5.0V LINEAR INTEGRATED CIRCUIT

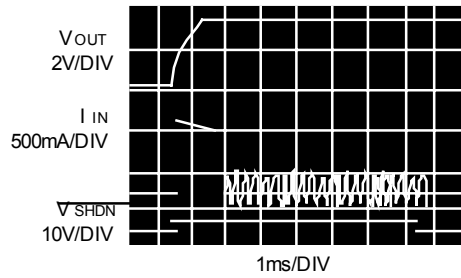
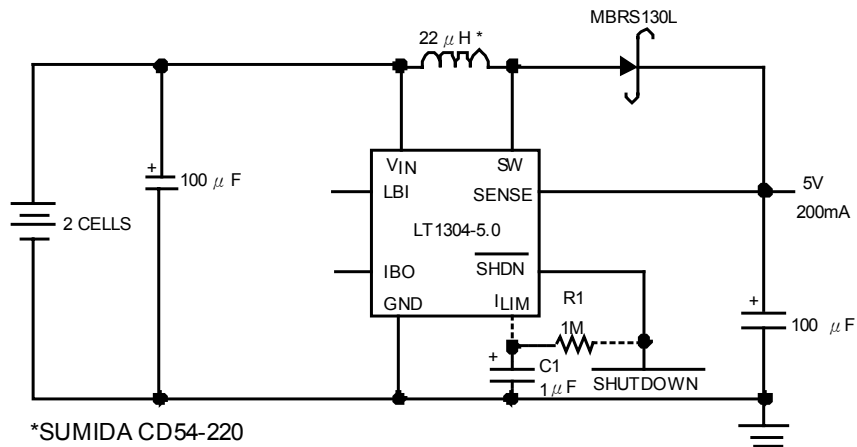

Figure 3. Start-Up Response. Input Current Rises Quickly to 1A. VOUT Reaches 5V in Approximately 1ms. Output Drives 20mA Load



*SUMIDA CD54-220

Figure 4. 2-Cell to 5V/200mA Boost Converter Takes Four External Parts. Components with Dashed Lines Are for Soft Start (Optional)

If the full power capability of the LT1304 is not required, peak switch current can be limited by connecting a resistor R_{LIM} from the I_{LIM} pin to ground. With $R_{LIM} = 22k$, peak switch current is reduced to approximately 500mA. Smaller power components can then be used. The graph in Figure 6 shows switch current vs R_{LIM} resistor value.

UTC LT1304/LT1304-3.3V/LT1304-5.0V LINEAR INTEGRATED CIRCUIT

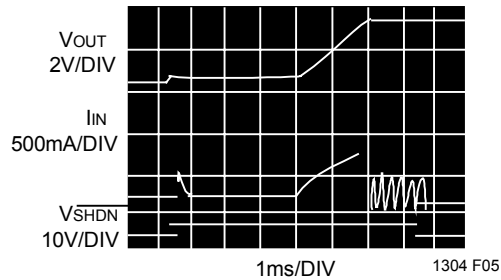

Figure 5. Start-Up Response with $1\ \mu\text{F}/1\text{M}\Omega$ Components in Figure 2 Added. Input Current Is More Controlled. V_{OUT} Reaches 5V in 6ms. Output Drives 20mA Load.

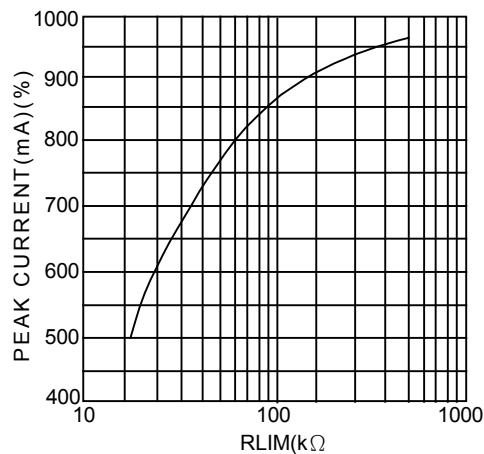

Figure 6. Peak Switch Current vs R_{LIM} Value

LAYOUT/INPUT BYPASSING

The LT1304 high speed switching mandates careful attention to PC board layout. Suggested component placement is shown in Figure 7. The input supply must have low impedance at AC and the input capacitor should be placed as indicated in the figure. The value of this capacitor depends on how close the input supply is to the IC. In situations where the input supply is more than a few inches away from the IC, a $47\ \mu\text{F}$ to $100\ \mu\text{F}$ solid tantalum bypass capacitor is required. If the input supply is close to the IC, a $1\ \mu\text{F}$ ceramic capacitor can be used instead. The LT1304 switches current in 1A pulses, so a low impedance supply must be available. If the power source (for example, a 2AA cell battery) is within 1 or 2 inches of the IC, the battery itself provides bulk capacitance and the $1\ \mu\text{F}$ ceramic capacitor acts to smooth voltage spikes at switch turn-on and turn-off. If the power source is far away from the IC, inductance in the power source leads results in high impedance at high frequency. A local high capacitance bypass is then required to restore low impedance at the IC.

UTC LT1304/LT1304-3.3V/LT1304-5.0V LINEAR INTEGRATED CIRCUIT

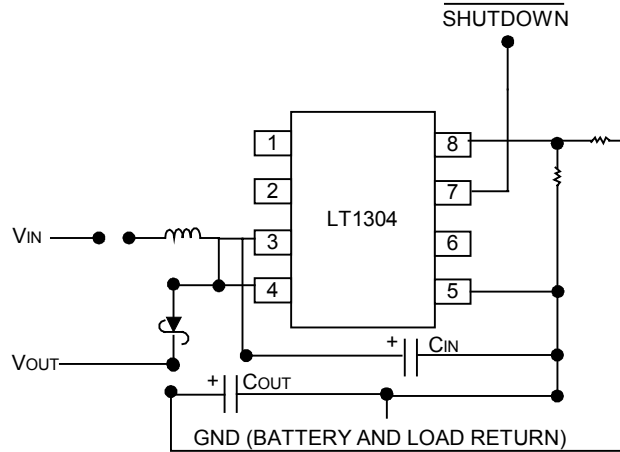

Figure 7. Suggested Layout for Best Performance. Input Capacitor Placement as Shown Is Highly Recommended. Switch Trace (pin 4) Copper Area Is Minimized

Low-Battery Detector

The LT1304 contains an independent low-battery detector that remains active when the device is shut down. This detector, actually a hysteretic comparator, has an open collector output that can sink up to 500 μ A. The comparator also operates below the switcher's undervoltage lockout threshold, operating until V_{IN} reaches approximately 1.4V. Figure 8 illustrates the input/output characteristic of the detector. Hysteresis is clearly evident in the figure.

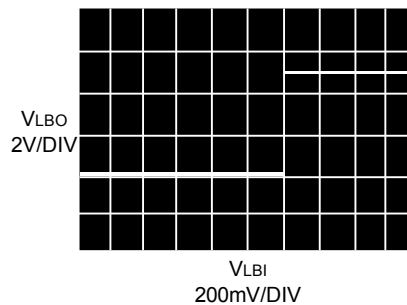

Figure 8. Low-Battery Detector Transfer Function.
Pull-Up R=22K, V_{IN} =2V, Sweep Frequency=10Hz

Battery Life

How many hours does it work? This is the bottom line question that must be asked of any efficiency study. AA alkaline cells are not perfect power sources. For efficient power transfer, energy must be taken from AA cells at a rate that does not induce excessive loss. AA cells internal impedance, about 0.2 Ω fresh and 0.5 Ω end-of-life, results in significant efficiency loss at high discharge rates. Figure 10 illustrates battery life vs load current of Figure 9's LT1304, 2-cell to 5V DC/DC converter. Note the accelerated decrease in hours at higher power levels. Figure 11 plots total watt hours vs load current. Watt hours are determined by the following formula:
 $WH = I_{LOAD}(5V)(H)$

UTC LT1304/LT1304-3.3V/LT1304-5.0V LINEAR INTEGRATED CIRCUIT

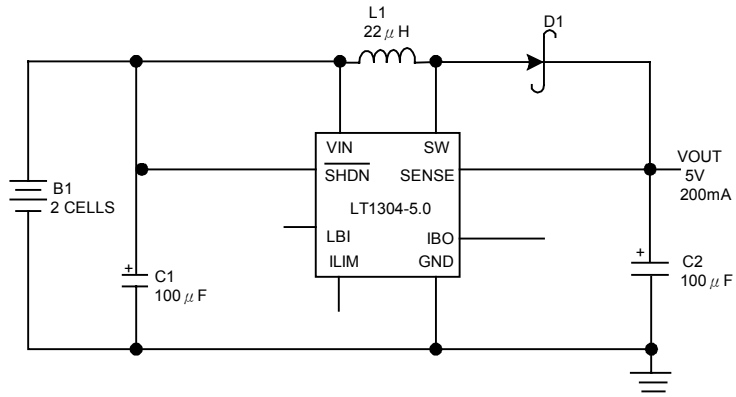

Figure 9. 2-cell to 5V Converter Used in Battery Life Study

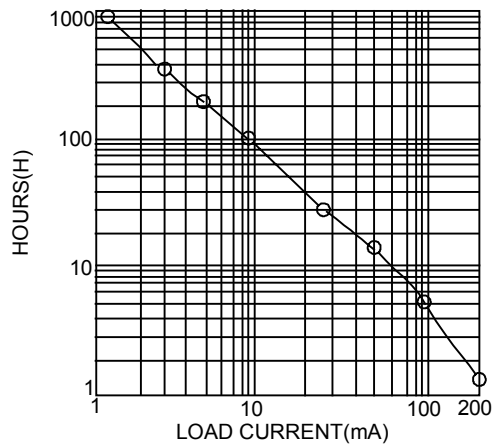

Figure 10. Battery Life vs Current. Dots Specify Actual Measurements

UTC LT1304/LT1304-3.3V/LT1304-5.0V LINEAR INTEGRATED CIRCUIT

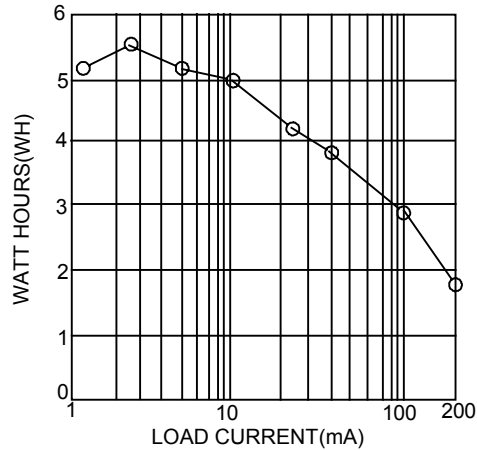

Figure 11. Output Wall Hours vs Load Current.
Note Rapid Fall-Off at Higher Discharge Rates

Figure 11's graph varies significantly from electrical efficiency plot pictured on the first page of this data sheet. Why? As more current is drawn from the battery, voltage drop across the cells' internal impedance increases. This causes internal power loss (heating), reducing cell terminal voltage. Since the regulator input acts as a negative resistance, more current is drawn from the battery as the terminal voltage decreases. This positive feedback action compounds the problem.

Figure 12 shows overall energy conversion efficiency, assuming availability of 6.5WH of battery energy. This efficiency approximates the electrical efficiency at load current levels from 1mA to 10mA, but drops severely at load currents above 10mA (load power above 50mW). The moral of the story is this: if your system needs 5V at more than 40mA to 50mA, consider using a NiCd battery (1/10 the internal impedance) instead of a AA cell alkaline battery.

UTC LT1304/LT1304-3.3V/LT1304-5.0V LINEAR INTEGRATED CIRCUIT

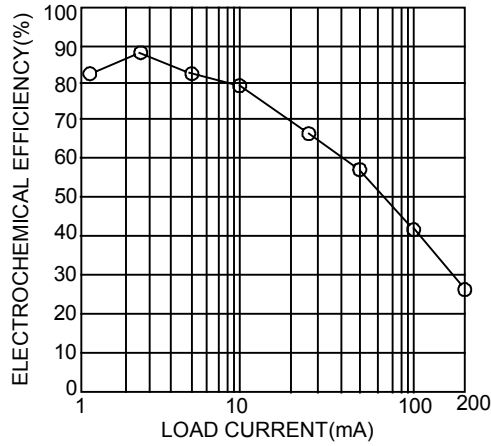
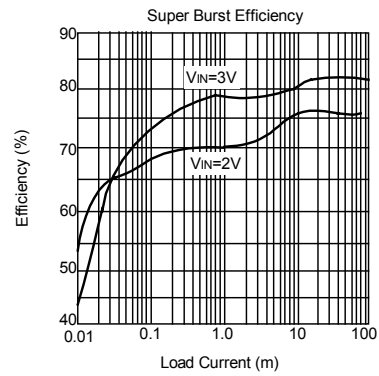
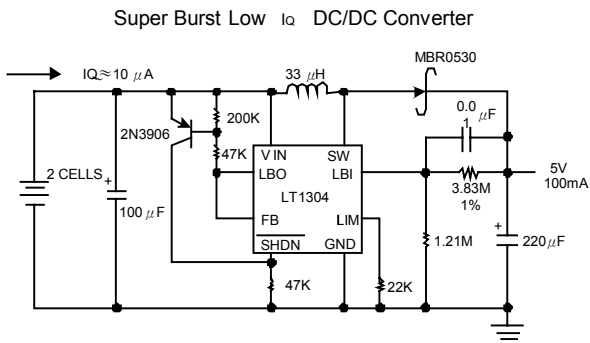

Figure 12. Overall System Efficiency Including Battery Efficiency vs Load Current. Internal Impedance of Alkaline AA Cells Accounts for Rapid Drop in Efficiency at Higher Load Current

TYPICAL CHARACTERISTICS



UTC LT1304/LT1304-3.3V/LT1304-5.0V LINEAR INTEGRATED CIRCUIT

2-Cell to 3.3V Boost Converter

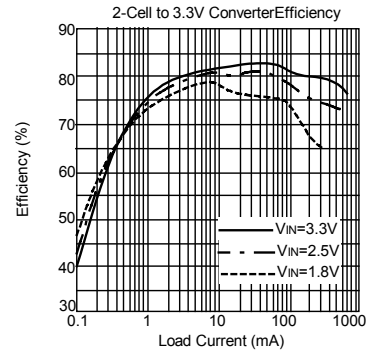
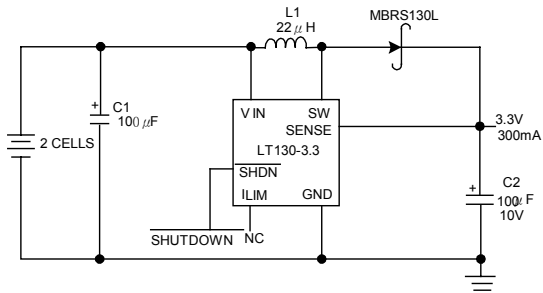

3.3V SEPIC Efficiency (Step-Up/Step-Down Converter)

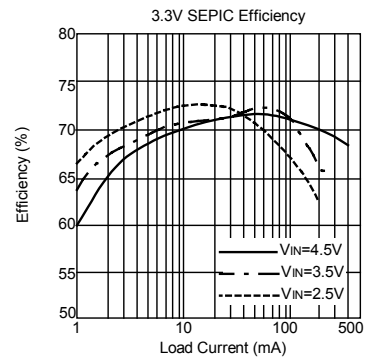
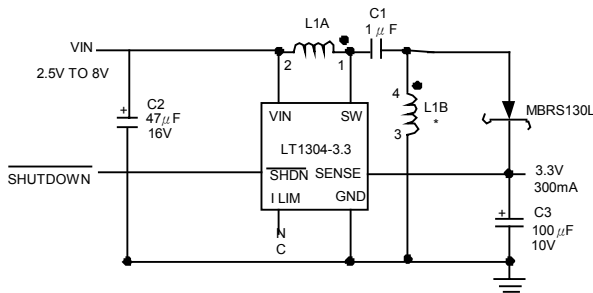

5V SPEC (Step-Up/Step-Down Converter)

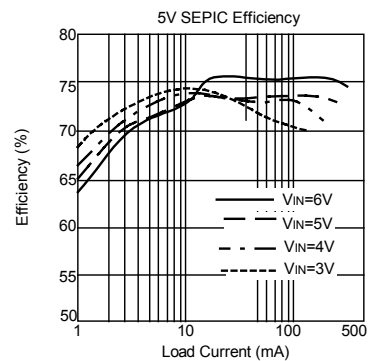
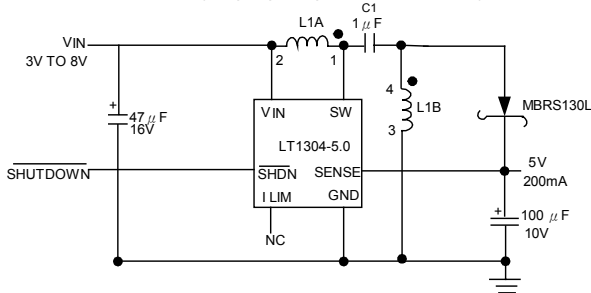

UTC LT1304/LT1304-3.3V/LT1304-5.0V LINEAR INTEGRATED CIRCUIT

5V to 12V DC/DC Converter

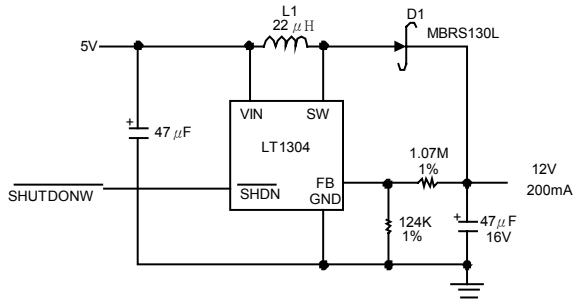

5V to 12V Converter Efficiency

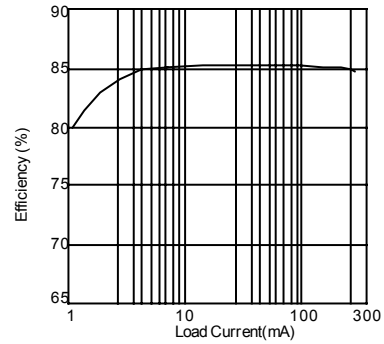

Single Li-Ion Cell to 5V Converter with Load Disconnect at $V_{in} < 2.7V$

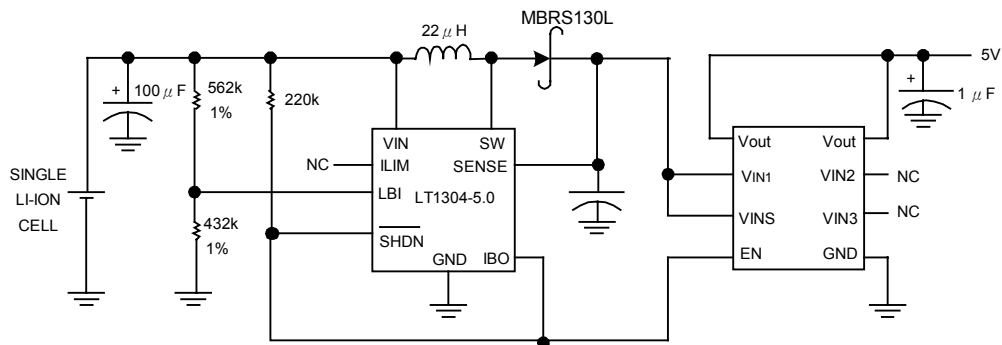

UTC LT1304/LT1304-3.3V/LT1304-5.0V LINEAR INTEGRATED CIRCUIT

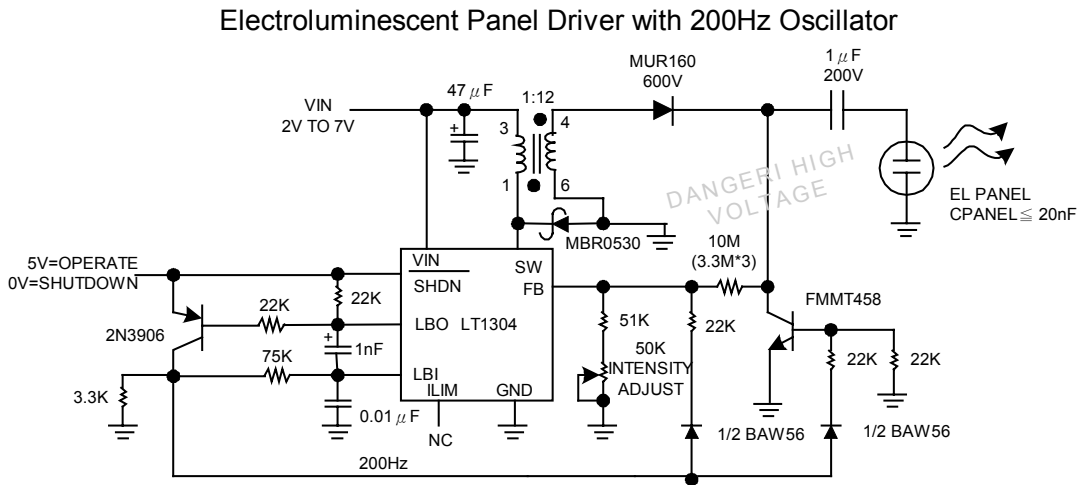
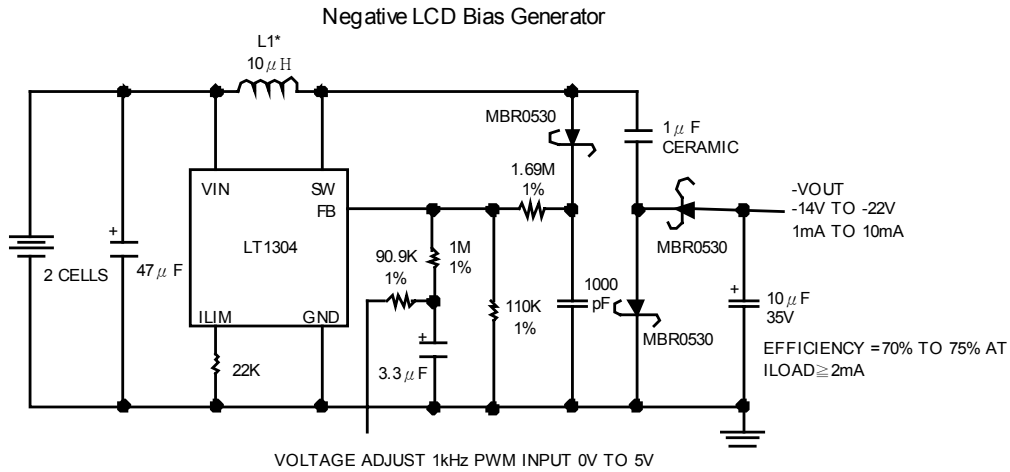

UTC LT1304/LT1304-3.3V/LT1304-5.0V LINEAR INTEGRATED CIRCUIT

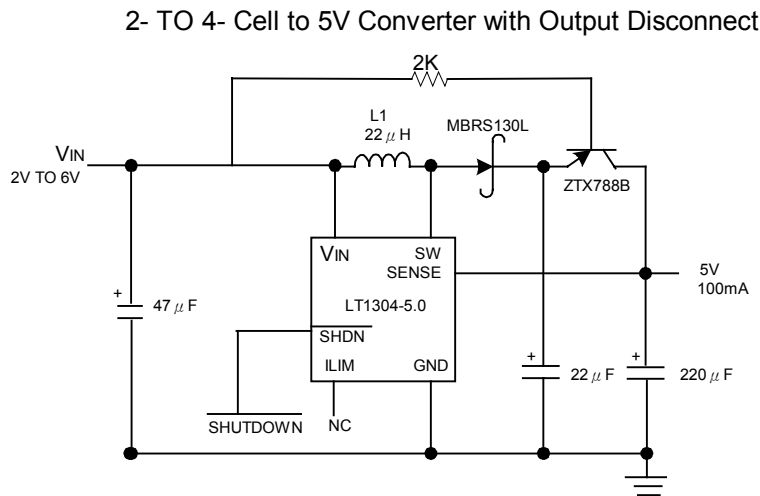
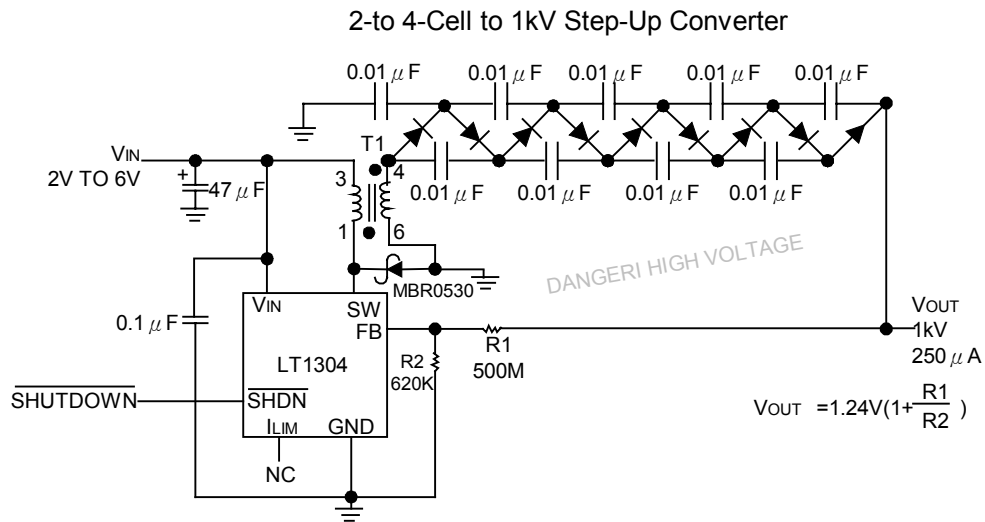

UTC LT1304/LT1304-3.3V/LT1304-5.0V LINEAR INTEGRATED CIRCUIT

2- Cell to 5V Converter with Auxiliary 10V Output

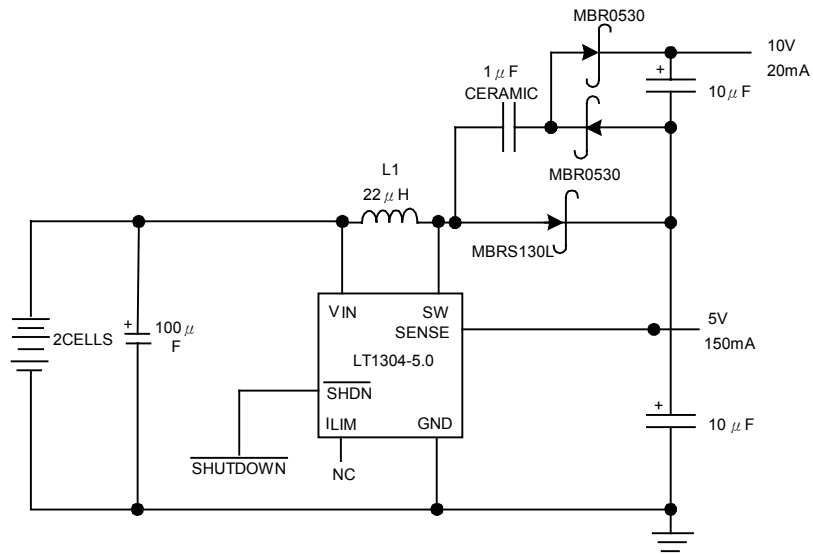

2- Cell to 5V Converter with Auxiliary -5V Output

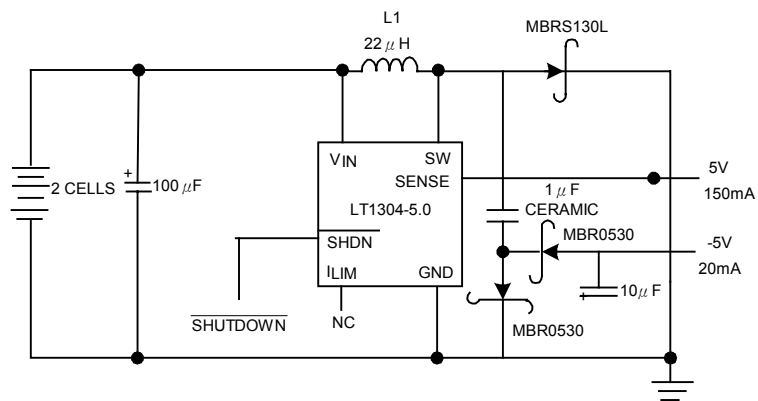

UTC LT1304/LT1304-3.3V/LT1304-5.0V LINEAR INTEGRATED CIRCUIT

UTC assumes no responsibility for equipment failures that result from using products at values that exceed, even momentarily, rated values (such as maximum ratings, operating condition ranges, or other parameters) listed in products specifications of any and all UTC products described or contained herein. UTC products are not designed for use in life support appliances, devices or systems where malfunction of these products can be reasonably expected to result in personal injury. Reproduction in whole or in part is prohibited without the prior written consent of the copyright owner. The information presented in this document does not form part of any quotation or contract, is believed to be accurate and reliable and may be changed without notice.

UTC UNISONIC TECHNOLOGIES CO., LTD. 19

QW-R103-018,A