



M2073

LINEAR INTEGRATED CIRCUIT

DUAL LOW VOLTAGE POWER AMPLIFIER

DESCRIPTION

As a dual low voltage power amplifier, the UTC **M2073** has the internal circuits, such as parasitic oscillation preventing circuit and muting circuit.

Considering the fixed gain of UTC **M2073**, there's an additional voltage reducing application for the UTC **M2073**.

The normal application of **M2073** is being used as a dual audio power amplifier in lots of portable equipments.

FEATURES

- * Operating Voltage ($V_{CC}=1.8V\sim 15V$)
- * Low Crossover Distortion
- * Low Operating Current
- * Bridge or Stereo Configuration
- * No Turn-on Noise
- * Bipolar Technology

ORDERING INFORMATION

Ordering Number			Package	Packing
Normal	Lead Free Plating	Halogen Free		
M2073-D08-T	M2073L-D08-T	M2073G-D08-T	DIP-8	Tube
M2073-SM1-R	M2073L-SM1-R	M2073G-SM1-R	MSOP-8	Tape Reel

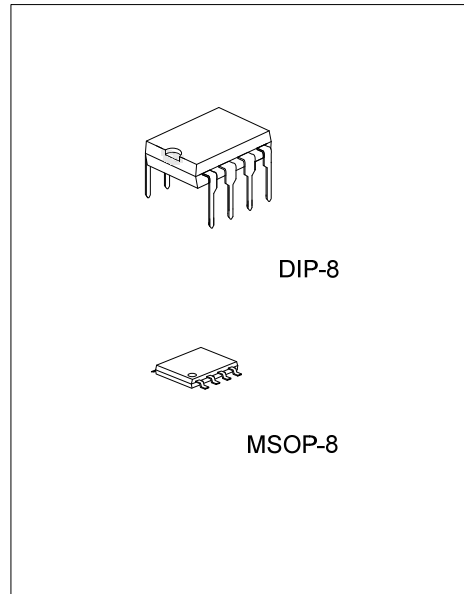

Lead-free: M2073L
 Halogen-free: M2073G

<p>M2073L-D08-T</p> <p>(1)Packing Type (2)Package Type (3)Lead Plating</p>	<p>(1) T: Tube, R: Tape Reel (2) D08: DIP-8, SM1: MSOP-8 (3) G: Halogen Free, L: Lead Free, Blank: Pb/Sn</p>
--	--

■ PIN CONFIGURATION

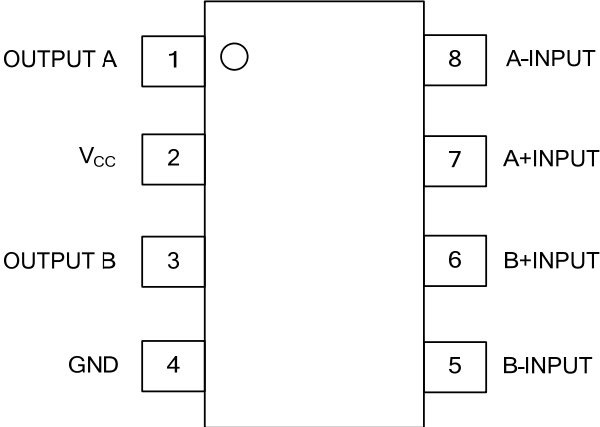

■ BLOCK DIAGRAM

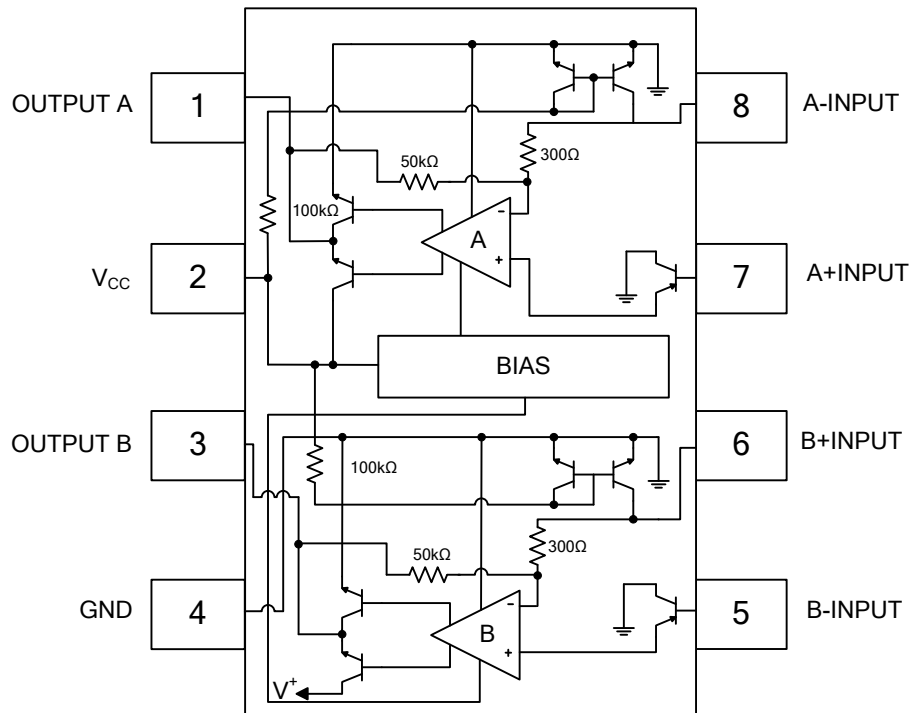

■ ABSOLUTE MAXIMUM RATING

PARAMETER	SYMBOL	RATINGS	UNIT
Supply Voltage	V_{CC}	15	V
Input Voltage Range	V_{IN}	± 0.4	V
Output Peak Current	I_{OP}	1	A
Power Dissipation	DIP-8	700	mW
	MSOP-8	300	mW
Junction Temperature	T_J	125	$^{\circ}C$
Operating Temperature	T_{OPR}	-40 ~ +85	$^{\circ}C$
Storage Temperature	T_{STG}	-40 ~ +125	$^{\circ}C$

Note Absolute maximum ratings are those values beyond which the device could be permanently damaged

Absolute maximum ratings are stress ratings only and functional device operation is not implied.

■ ELECTRICAL CHARACTERISTICS

BTL Configuration (Page 6) ($V_{CC}=6V, T_a=25^{\circ}C$)

PARAMETER	SYMBOL	TEST CONDITIONS	MIN	TYP	MAX	UNIT	
Operating Voltage	V_{CC}		1.8		15	V	
Operating Current	I_{CC}	$R_L = \infty$		6	9	mA	
Output Offset Voltage (Between the Outputs)	ΔV_{OUT}	$R_L = 8\Omega$		10	50	mV	
Input Bias Current	$I_{I(BIAS)}$			100		nA	
Output Power	P_{OUT}	THD=10% f=1kHz	DIP-8	$V_{CC} = 9V, R_L = 16\Omega$ (Note)	2.0	W	
				$V_{CC} = 6V, R_L = 8\Omega$ (Note)	0.9	1.2	W
				$V_{CC} = 4.5V, R_L = 8\Omega$	0.6	W	
				$V_{CC} = 4.5V, R_L = 4\Omega$ (Note)	0.8	W	
				$V_{CC} = 3V, R_L = 4\Omega$	200	300	mW
				$V_{CC} = 2V, R_L = 4\Omega$	80	mW	
		THD=1% f=40Hz~15kHz	MSOP-8	$V_{CC} = 6V, R_L = 16\Omega$ (Note)	0.8	W	
				$V_{CC} = 4V, R_L = 8\Omega$ (Note)	350	460	mW
				$V_{CC} = 3V, R_L = 4\Omega$ (Note)	200	300	mW
				$V_{CC} = 2V, R_L = 4\Omega$	80	mW	
				DIP-8	$V_{CC} = 6V, R_L = 8\Omega$	1.0	W
					$V_{CC} = 4.5V, R_L = 4\Omega$	0.6	W
Total Harmonic Distortion	THD	$P_{OUT} = 0.5W, R_L = 8\Omega, f = 1kHz$	DIP-8	0.2	%		
		$V_{CC} = 4V, R_L = 8\Omega, P_{OUT} = 200mW, R_L = 8\Omega, f = 1kHz$	MSOP-8	0.2	%		
Close Loop Voltage Gain	G_V	f=1kHz	41	44	47	dB	
Input Impedance	Z_{IN}	f=1kHz	100			k Ω	
Equivalent Input Noise Voltage	V_{NI1}	$R_S = 10k\Omega, A$ Curve		2		μV	
	V_{NI2}	$R_S = 10k\Omega, B = 22Hz \sim 22kHz$		2.5		μV	
Ripple Rejection	RR	f=100Hz		40		dB	
Cutoff Frequency	f_H	$G_V = -3dB$ from f=1kHz, $R_L = 8\Omega, P_{OUT} = 1W$	DIP-8	130		kHz	
		$G_V = -3dB$ from f=1kHz, $R_L = 16\Omega, P_{OUT} = 0.5W$	MSOP-8	130		kHz	

Note: At on PC Board

■ ELECTRICAL CHARACTERISTICS(Cont.)

Stereo Configuration (Page 7)

PARAMETER	SYMBOL	TEST CONDITIONS	MIN	TYP	MAX	UNIT	
Operating Voltage	V_{CC}		1.8		15	V	
Output Voltage	V_{OUT}			2.7		V	
Operating Current	I_{CC}	$R_L = \infty$		6	9	mA	
Input Bias Current	$I_{I(BIAS)}$			100		nA	
Output Power (Each Channel)	P_{OUT}	THD=10% f=1kHz	DIP-8	$V_{CC} = 6V, R_L = 4\Omega$ (Note)	0.5	0.65	W
				$V_{CC} = 4.5V, R_L = 4\Omega$		0.32	W
				$V_{CC} = 3V, R_L = 4\Omega$		120	mW
				$V_{CC} = 2V, R_L = 4\Omega$		30	mW
		THD=10% f=1kHz	MSOP-8	$V_{CC} = 6V, R_L = 16\Omega$		240	mW
				$V_{CC} = 5V, R_L = 8\Omega$ (Note)		270	mW
				$V_{CC} = 4V, R_L = 4\Omega$ (Note)	180	250	mW
				$V_{CC} = 3V, R_L = 4\Omega$		120	mW
				$V_{CC} = 2V, R_L = 4\Omega$		30	mW
		THD=1% f=1kHz	DIP-8	$V_{CC} = 6V, R_L = 4\Omega$		500	mW
				$V_{CC} = 4.5V, R_L = 4\Omega$		250	mW
			MSOP-8		180	mW	
		Total Harmonic Distortion	THD	$P_{OUT} = 0.4W, R_L = 4\Omega, f = 1kHz$	DIP-8		0.25
$V_{CC} = 4V, R_L = 4\Omega, P_{OUT} = 150mW, f = 1kHz$	MSOP-8				0.25	%	
Voltage Gain	G_V	f=1kHz	41	44	47	dB	
Channel Balance	ΔG_V				± 1	dB	
Input Impedance	Z_{IN}	f=1kHz	100			k Ω	
Equivalent Input Noise Voltage	V_{NI1}	$R_S = 10k\Omega, A$ Curve		2.5		μV	
	V_{NI2}	$R_S = 10k\Omega, B = 22Hz \sim 22kHz$		3		μV	
Ripple Rejection	RR	f=100Hz, $C_X = 100\mu F$	24	30		dB	
Cutoff Frequency	f_H	$G_V = -3dB$ from f=1kHz, $R_L = 8\Omega, P_{OUT} = 250mW$	DIP-8		200	kHz	
		$G_V = -3dB$ from f=1kHz, $R_L = 16\Omega, P_{OUT} = 125mW$	MSOP-8		200	kHz	

Note: At on PC Board

APPLICATION CIRCUITS FOR BTL MODE

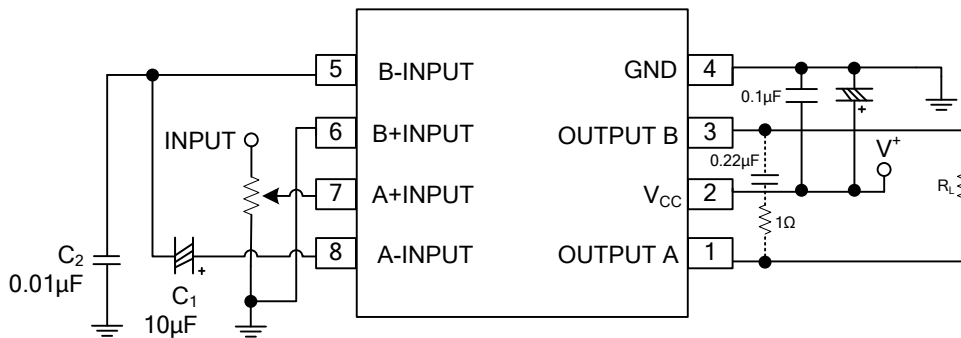

BTL Configuration Applaitaion Circuit

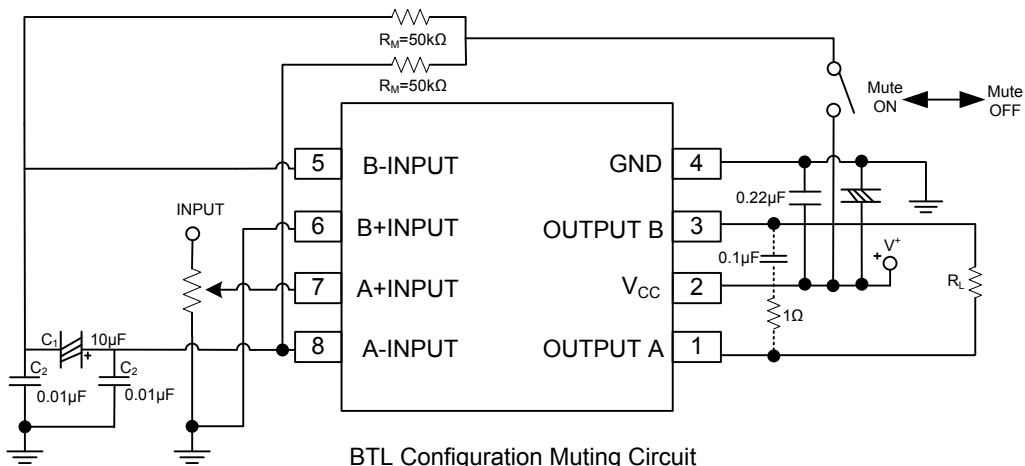

BTL Configuration Muting Circuit

APPLICATION CIRCUITS FOR STEREO MODE

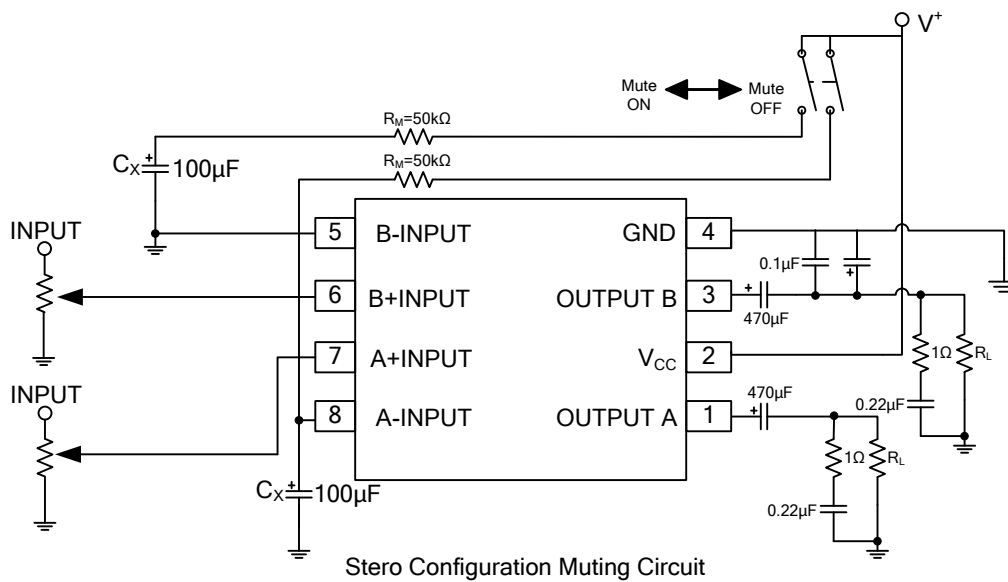
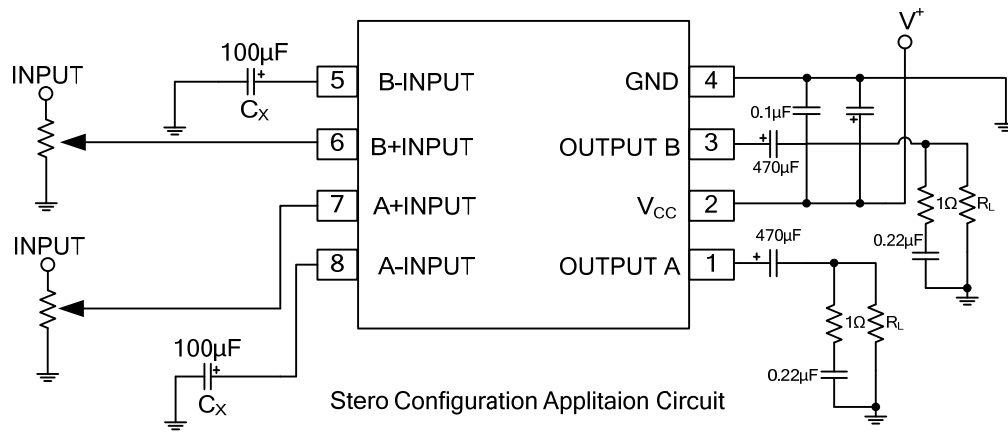

■ TYPICAL CHARACTERISTICS

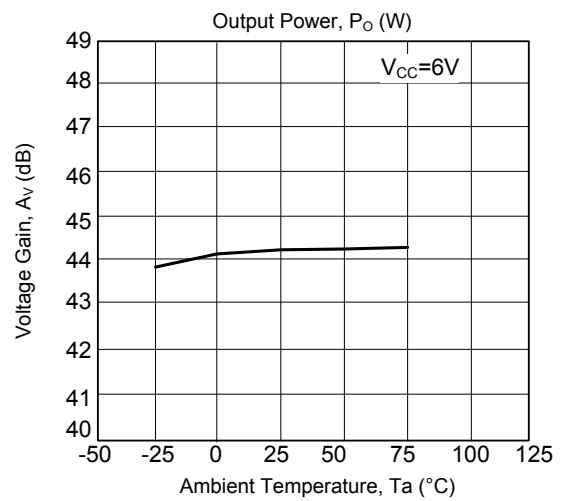
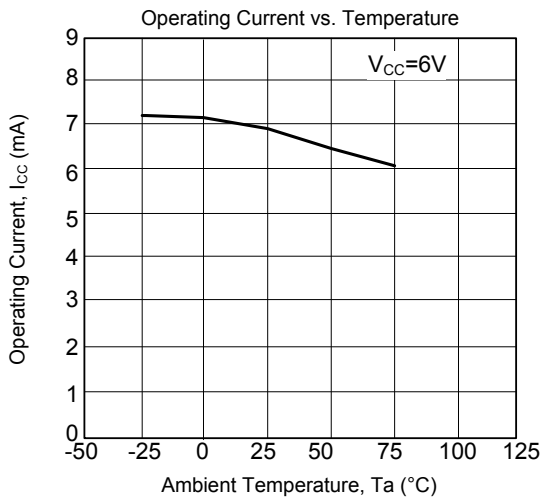
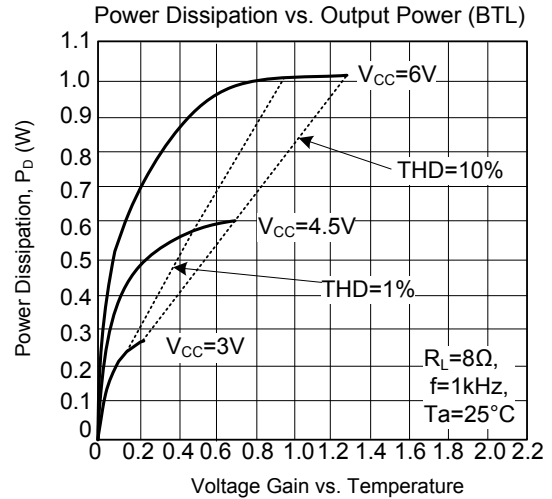
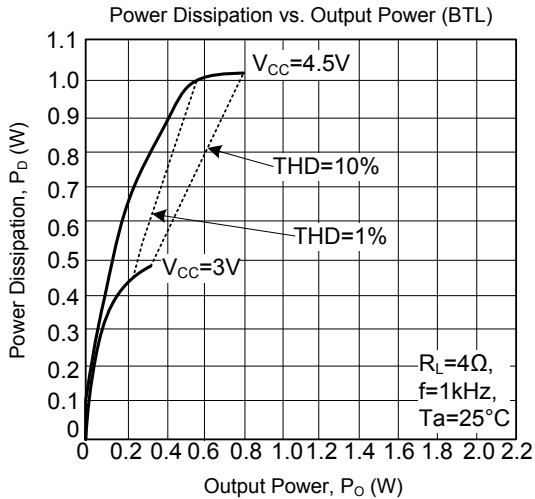
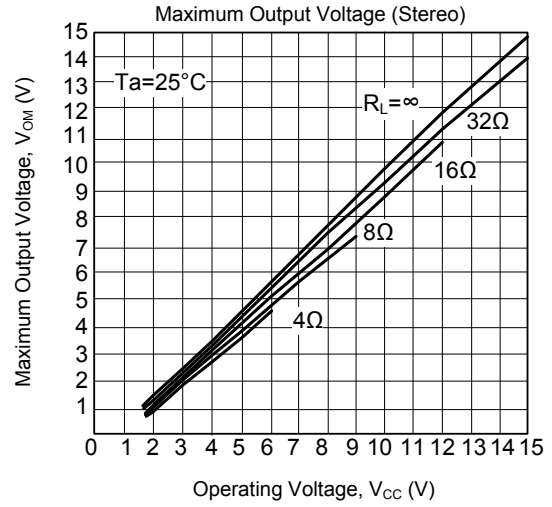
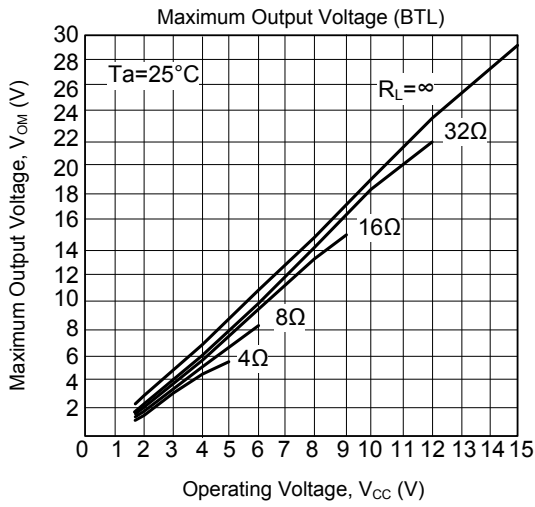

■ TYPICAL CHARACTERISTICS (Cont.)

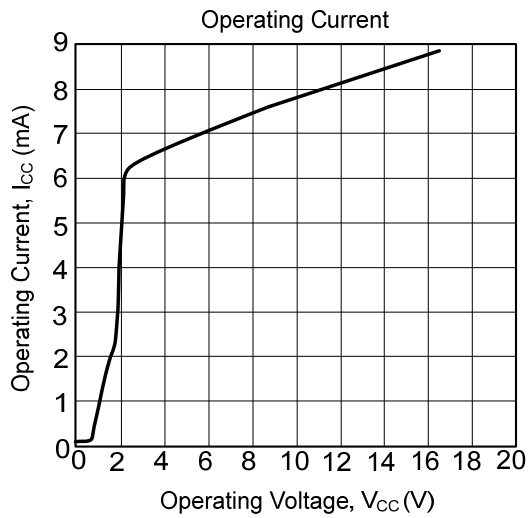

UTC assumes no responsibility for equipment failures that result from using products at values that exceed, even momentarily, rated values (such as maximum ratings, operating condition ranges, or other parameters) listed in products specifications of any and all UTC products described or contained herein. UTC products are not designed for use in life support appliances, devices or systems where malfunction of these products can be reasonably expected to result in personal injury. Reproduction in whole or in part is prohibited without the prior written consent of the copyright owner. The information presented in this document does not form part of any quotation or contract, is believed to be accurate and reliable and may be changed without notice.