



M2100

LINEAR INTEGRATED CIRCUIT

SINGLE OPERATIONAL AMPLIFIER

DESCRIPTION

The UTC **M2100** is a low supply voltage and low saturation output voltage ($\pm 2.0V$ p-p at supply voltage $\pm 2.5V$) operational amplifier. It is applicable to handy type CD, radio cassette CD, and portable DAT, that are digital audio apparatus which require the 5V single supply operation and high output voltage.

FEATURES

- * Single Supply Operation
- * Operating Voltage ($\pm 1.0V \sim \pm 3.5V$)
- * Low Saturation Output Voltage
- * High Slew Rate ($4V/\mu s$ typ.)
- * Bipolar Technology

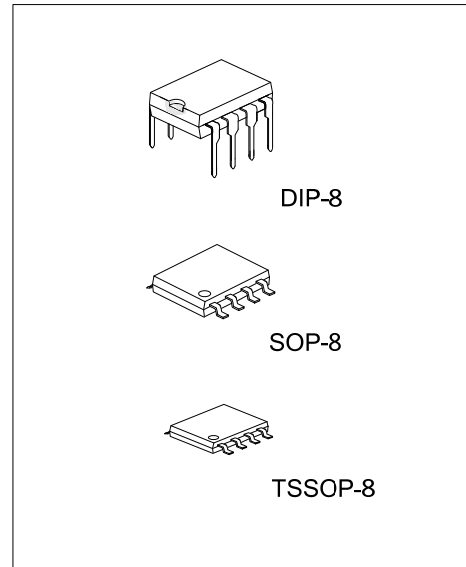

Lead-free: M2100L
Halogen-free: M2100G

ORDERING INFORMATION

	Ordering Number		Package	Packing
	Normal	Lead Free Plating		
M2100-D08-T	M2100L-D08-T	M2100G-D08-T	DIP-8	Tube
M2100-S08-R	M2100L-S08-R	M2100G-S08-R	SOP-8	Tape Reel
M2100-P08-R	M2100L-P08-R	M2100G-P08-R	TSSOP-8	Tape Reel

<p>M2100L-D08-T</p> <p>(1) Packing Type</p> <p>(2) Package Type</p> <p>(3) Lead Plating</p>	<p>(1) R: Tape Reel, T: Tube</p> <p>(2) D08: DIP-8, S08: SOP-8, P08: TSSOP-8</p> <p>(3) G: Halogen Free, L: Lead Free, Blank: Pb/Sn</p>
---	---

■ PIN CONFIGURATION

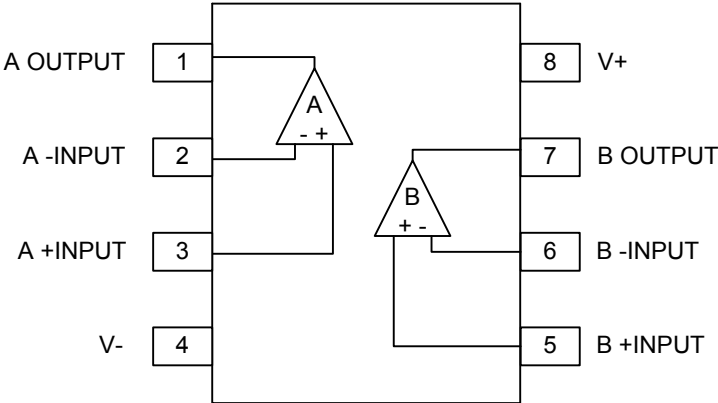

■ BLOCK DIAGRAM

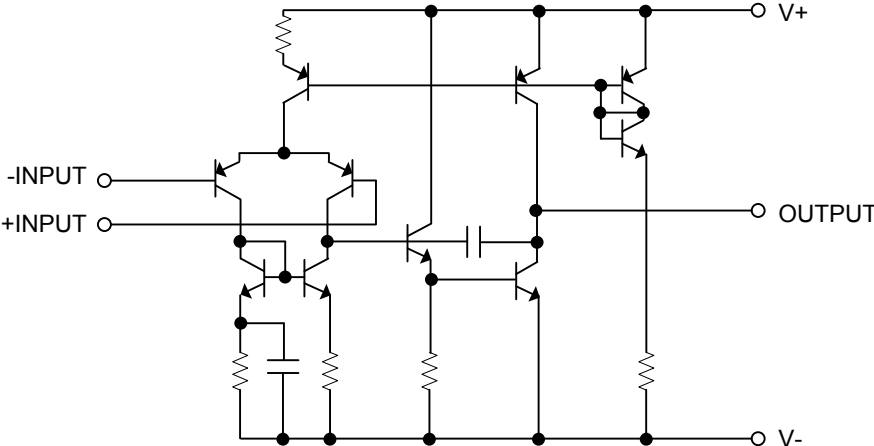

■ ABSOLUTE MAXIMUM RATING (Ta=25°C, unless otherwise specified)

PARAMETER	SYMBOL	RATINGS	UNIT
Supply Voltage	V+/V-	±3.5	V
Differential Input Voltage	V _{I(DIFF)}	±7	V
Power Dissipation	DIP-8	500	mW
	SOP-8	300	mW
	TSSOP-8	250	mW
Operating Temperature Range	T _{OPR}	-40~ +85	°C
Storage Temperature Range	T _{STG}	-40~ +125	°C

Note: Absolute maximum ratings are those values beyond which the device could be permanently damaged. Absolute maximum ratings are stress ratings only and functional device operation is not implied.

■ ELECTRICAL CHARACTERISTICS (V⁺=5V, Ta=25°C, unless otherwise specified)

PARAMETER	SYMBOL	TEST CONDITIONS	MIN	TYP	MAX	UNIT
Input Offset Voltage	V _{I(OFF)}	R _s ≤ 10kΩ		1	6	mV
Input Bias Current	I _{I(BIAS)}			100	300	nA
Operating Current	I _{CC}	V _{IN} =0, R _L =∞		3.5	5	mA
Maximum Output Voltage Swing	V _{OM}	R _L ≥ 2.5kΩ	±2	±2.2		V
Input Common Mode Voltage Range	V _{ICM}		±1.5			V
Large Signal Voltage Gain	G _V	R _L ≥ 10kΩ	60	80		dB
Common Mode Rejection Ratio	CMRR		60	74		dB
Supply Voltage Rejection Ratio	SVR		60	80		dB
Slew Rate	SR	V _{IN} =±1V, G _V =1		4		V/μS
Gain-Bandwidth product	GB	f=10kHz		12		MHz

Notes: 1. Applied circuit voltage gain is desired to be operated within the range of 3dB~30dB.

2. Special care being required for input common mode voltage range and the oscillation due to the capacitive load when operating on voltage follower.

3. Special care being required for the oscillation, yet having the gain when the supply voltage is applied at more than 5V (single supply voltage 5V)

TYPICAL CHARACTERISTICS

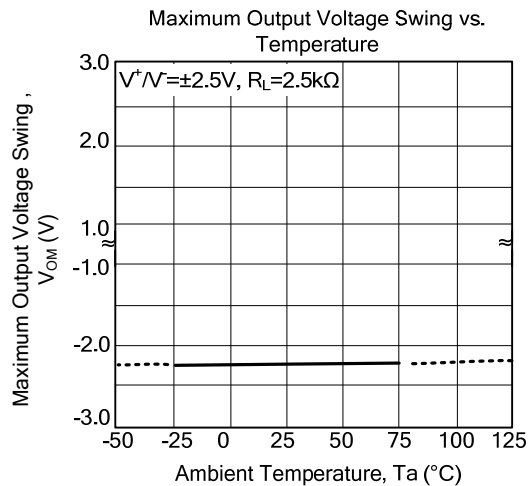
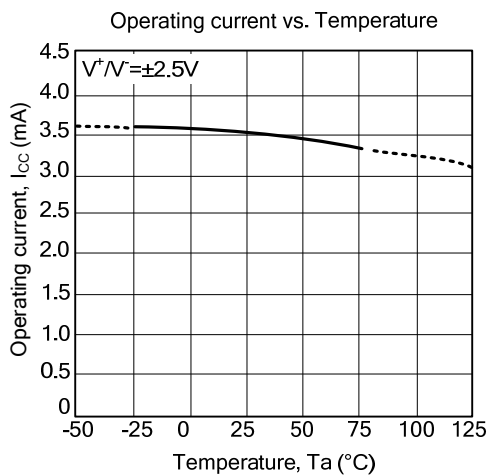
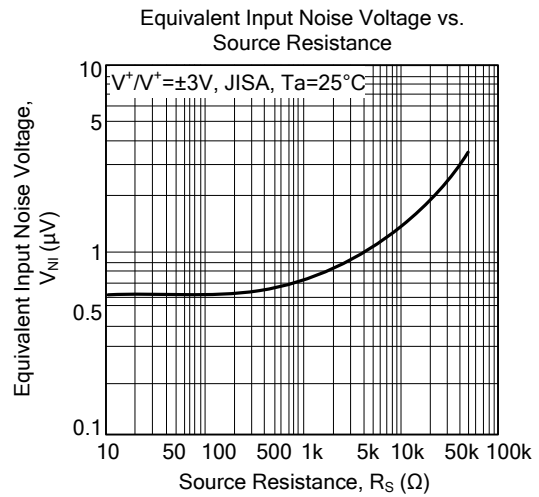
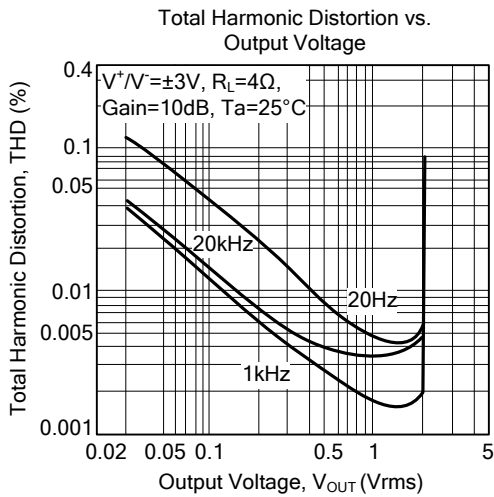
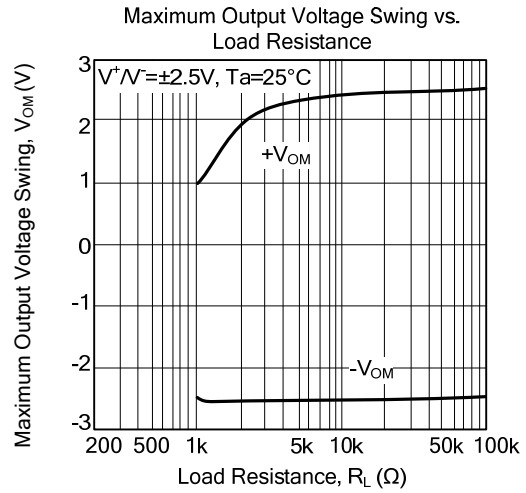
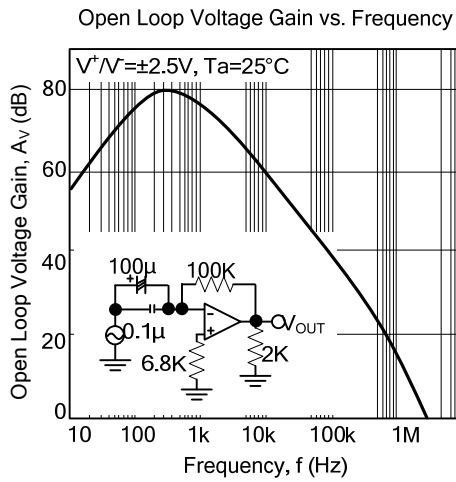

■ TYPICAL CHARACTERISTICS(Cont.)

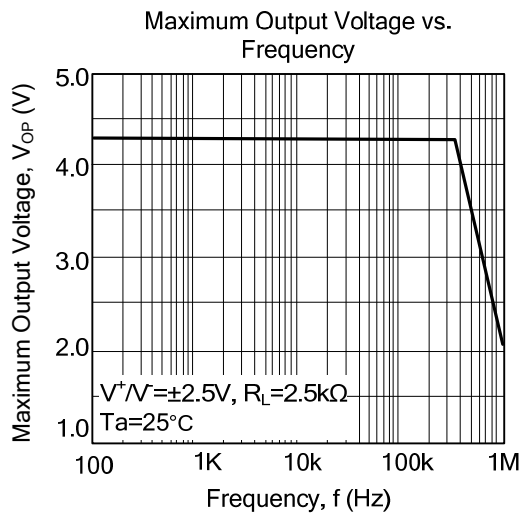
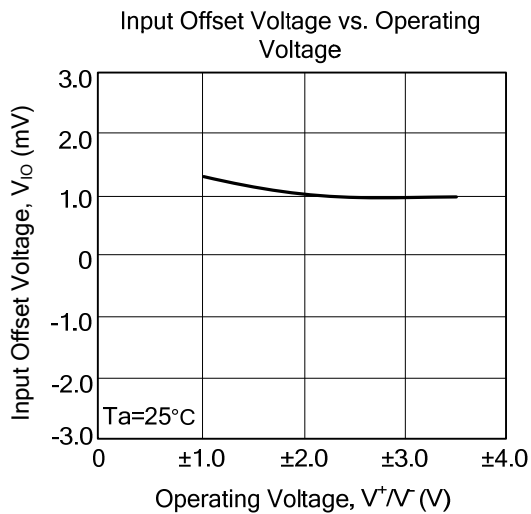
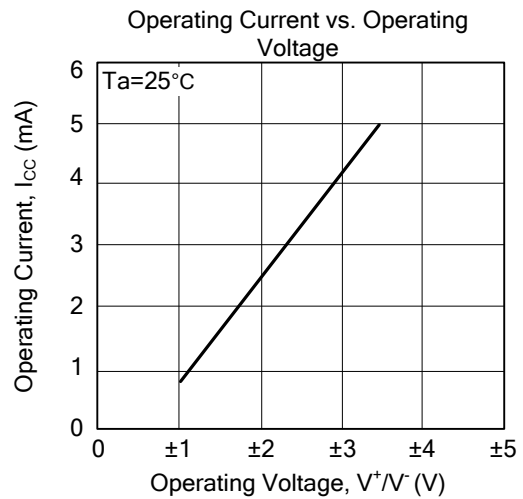
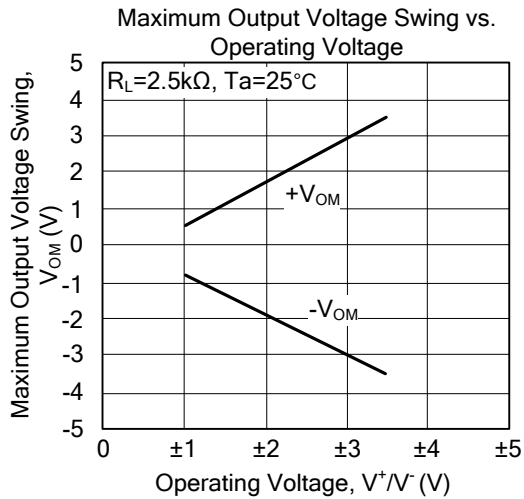
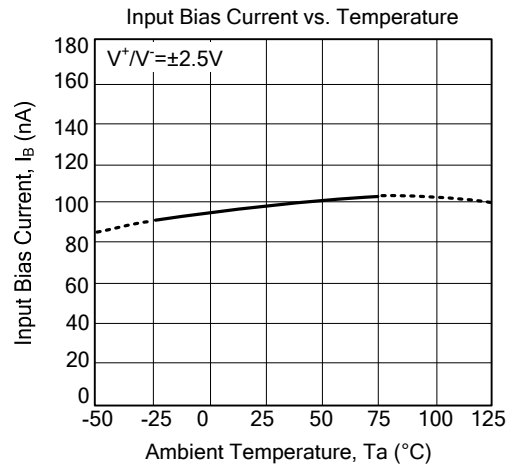
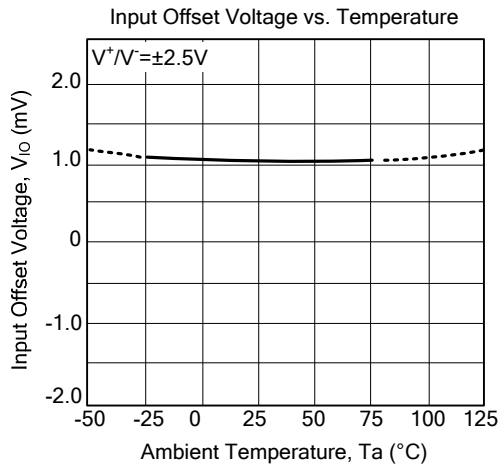

UTC assumes no responsibility for equipment failures that result from using products at values that exceed, even momentarily, rated values (such as maximum ratings, operating condition ranges, or other parameters) listed in products specifications of any and all UTC products described or contained herein. UTC products are not designed for use in life support appliances, devices or systems where malfunction of these products can be reasonably expected to result in personal injury. Reproduction in whole or in part is prohibited without the prior written consent of the copyright owner. The information presented in this document does not form part of any quotation or contract, is believed to be accurate and reliable and may be changed without notice.