



## MJE13005D

Preliminary

**NPN SILICON TRANSISTOR**

### HIGH VOLTAGE FAST-SWITCHING NPN POWER TRANSISTOR

#### DESCRIPTION

The UTC **MJE13005D** is a high voltage fast-switching NPN power transistor. It is characterized by high breakdown voltage, high current capability, high switching speed and high reliability.

The UTC **MJE13005D** is intended to be used in energy-saving light, electronic ballast, high frequency switching power supply, high frequency power transform or common power amplifier, etc.

#### FEATURES

- \* High Breakdown Voltage
- \* High Current Capability
- \* High Switching Speed
- \* High Reliability
- \* RoHS-Compliant Product

#### INTERNAL SCHEMATIC DIAGRAM

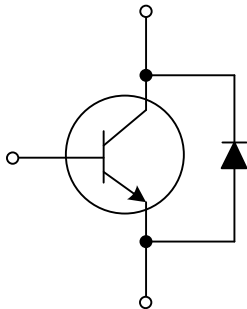

#### ORDERING INFORMATION

Ordering Number		Package	Pin Assignment			Packing
Lead Free	Halogen Free		1	2	3	
MJE13005DL-TA3-T	MJE13005DG-TA3-T	TO-220	B	C	E	Tube

<p>MJE13005DL-TA3-T</p> <ul style="list-style-type: none"> <li>(1) Packing Type</li> <li>(2) Package Type</li> <li>(3) Lead Plating</li> </ul>	<ul style="list-style-type: none"> <li>(1) T: Tube</li> <li>(2) TA3: TO-220</li> <li>(3) L: Lead Free Plating, G: Halogen Free</li> </ul>
--	---

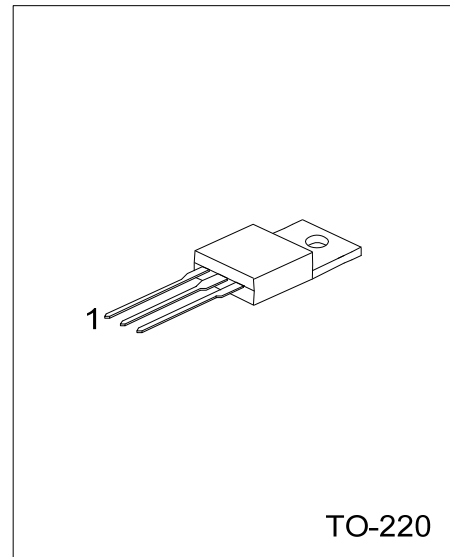

■ ABSOLUTE MAXIMUM RATING ( $T_C=25^\circ\text{C}$ )

PARAMETER		SYMBOL	RATING	UNIT
Collector- Emitter Voltage ( $V_{BE}=0$ )		$V_{CES}$	700	V
Collector-Emitter Voltage ( $I_B=0$ )		$V_{CEO}$	400	V
Emitter-Base Voltage		$V_{EBO}$	9	V
Collector Current	DC	$I_C$	4	A
	Pulse	$I_{CP}$	8	A
Base Current	DC	$I_B$	2	A
	Pulse	$I_{BP}$	4	A
Total Power Dissipation		$P_D$	75	W
Storage Temperature		$T_{STG}$	-55 ~ +150	$^\circ\text{C}$

Notes: 1. Absolute maximum ratings are those values beyond which the device could be permanently damaged.

Absolute maximum ratings are stress ratings only and functional device operation is not implied.

2. Pulse Test: Pulse Width = 5.0 ms, Duty Cycle < 10%.

■ THERMAL DATA

PARAMETER	SYMBOL	MIN	TYP	MAX	UNIT
Junction to Ambient	$\theta_{JA}$			62.5	$^\circ\text{C/W}$
Junction to Case	$\theta_{JC}$			1.67	$^\circ\text{C/W}$

■ ELECTRICAL CHARACTERISTICS

PARAMETER		SYMBOL	TEST CONDITIONS	MIN	TYP	MAX	UNIT
Collector-Emitter Breakdown Voltage		$BV_{CEO}$	$I_C=10\text{mA}, I_B=0$	400			V
Collector -Base Breakdown Voltage		$BV_{CBO}$	$I_C=1\text{mA}, I_B=0$	700			V
Emitter-Base Breakdown Voltage		$BV_{EBO}$	$I_E=1\text{mA}, I_C=0$	9			V
Collect Cut-off Current		$I_{CBO}$	$V_{CB}=700\text{V}, I_E=0$			100	$\mu\text{A}$
Collect Cut-off Current		$I_{CEO}$	$V_{CE}=400\text{V}, I_B=0$			50	$\mu\text{A}$
Emitter Cut-off Current		$I_{EBO}$	$V_{EB}=9\text{V}, I_C=0$			10	$\mu\text{A}$
DC Current Gain		$h_{FE1}$	$V_{CE}=5\text{V}, I_C=500\text{mA}$	8		50	
		$h_{FE2}$	$V_{CE}=5\text{V}, I_C=2\text{A}$	5			
Collector-Emitter Saturation Voltage		$V_{CE(SAT1)}$	$I_C=1\text{A}, I_B=0.2\text{A}$			0.8	V
		$V_{CE(SAT2)}$	$I_C=4\text{A}, I_B=1\text{A}$			2	V
Base-Emitter Saturation Voltage		$V_{BE(SAT)}$	$I_C=2\text{A}, I_B=0.5\text{A}$			1.6	V
Resistive Load	Fall Time	$t_F$	$V_{CC}=24\text{V}, I_C=2\text{A}, I_{B1}=-I_{B2}=0.4\text{A}$			0.7	$\mu\text{s}$
	Storage Time	$t_S$				4	$\mu\text{s}$
Current Gain Bandwidth Product		$f_T$	$V_{CE}=10\text{V}, I_C=0.5\text{A}$	4			MHz

UTC assumes no responsibility for equipment failures that result from using products at values that exceed, even momentarily, rated values (such as maximum ratings, operating condition ranges, or other parameters) listed in products specifications of any and all UTC products described or contained herein. UTC products are not designed for use in life support appliances, devices or systems where malfunction of these products can be reasonably expected to result in personal injury. Reproduction in whole or in part is prohibited without the prior written consent of the copyright owner. The information presented in this document does not form part of any quotation or contract, is believed to be accurate and reliable and may be changed without notice.