



## NE555

## LINEAR INTEGRATED CIRCUIT

### SINGLE TIMER

#### DESCRIPTION

The UTC NE555 is a highly stable timer integrated circuit. It can be operated in both Astable and Monostable mode. With monostable operation, the time delay is precisely controlled by one external and one capacitor. With a stable operation as an oscillator the frequency and duty cycle are both accurately controlled with two external resistors and one capacitor.

#### FEATURES

- \*High current driver capability(=200mA).
- \*Adjustable duty cycle.
- \*Timing from  $\mu\text{s}$  to hours.
- \*Turn off time less than  $2\mu\text{s}$ .
- \*Operates in both astable and monostable modes.

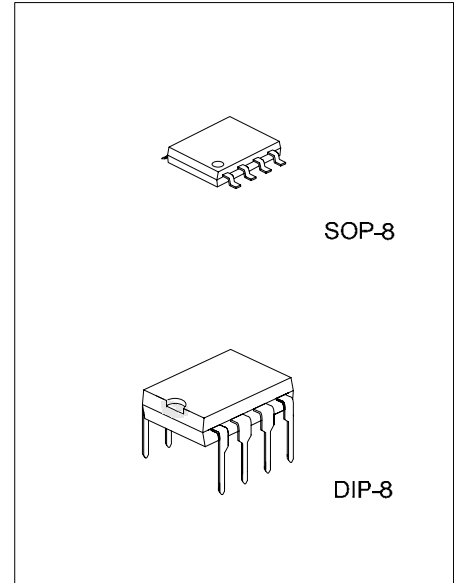

\*Pb-free plating product number: NE555L

#### ORDERING INFORMATION

Ordering Number		Package	Packing
Normal	Lead Free Plating		
NE555-D08-T	NE555L-D08-T	DIP-8	Tube
NE555-S08-R	NE555L-S08-R	SOP-8	Tape Reel
NE555-S08-T	NE555L-S08-T	SOP-8	Tube

<p>NE555L-D08-T</p> <p>(1)Packing Type (2)Package Type (3)Lead Plating</p>	<p>(1) R: Tape Reel, T: Tube (2) D08: DIP-8, S08: SOP-8 (3) L: Lead Free Plating, Blank: Pb/Sn</p>
--	--

### ■ PIN CONFIGURATION

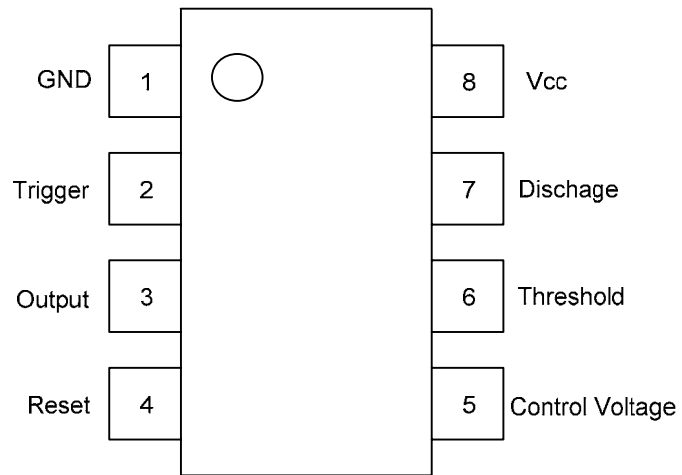

## ■ BLOCK DIAGRAM

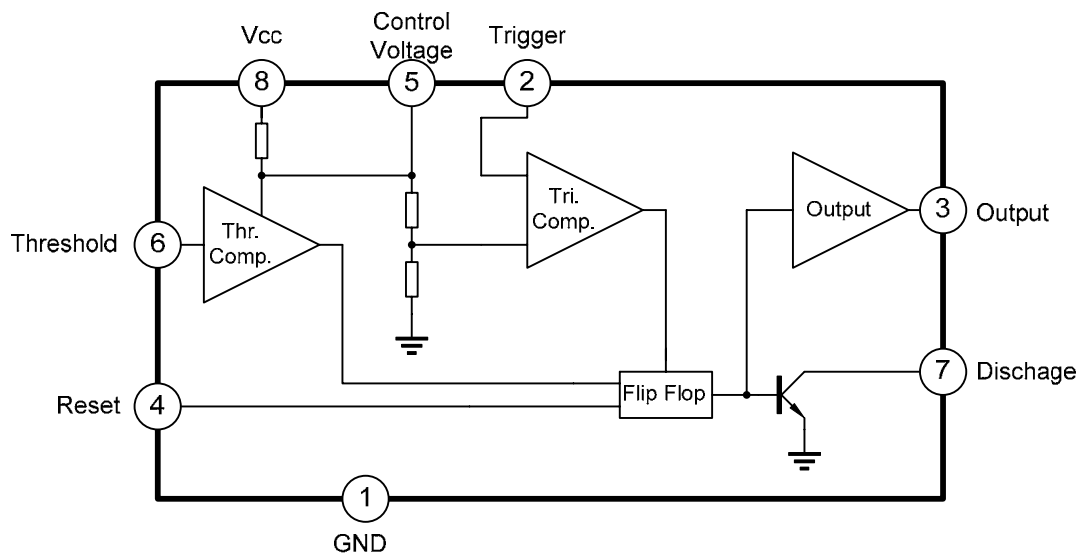

■ ABSOLUTE MAXIMUM RATINGS

PARAMETER	SYMBOL	RATINGS	UNIT
Supply Voltage	$V_{CC}$	16	V
Power Dissipation	$P_D$	600	mW
Junction Temperature	$T_J$	+125	
Operating Temperature	$T_{OPR}$	-20 ~ +85	
Storage Temperature	$T_{STG}$	-40 ~ +150	

Note: Absolute maximum ratings are those values beyond which the device could be permanently damaged. Absolute maximum ratings are stress ratings only and functional device operation is not implied.

■ ELECTRICAL CHARACTERISTICS ( $V_{CC}=5 \sim 15V$ ,  $T_a=25^\circ C$ , unless otherwise specified.)

PARAMETER	SYMBOL	TEST CONDITIONS	MIN	TYP	MAX	UNIT
Supply Voltage	$V_{CC}$		4.5		16	V
Supply Current (Note 1)	$I_{CC}$	$V_{CC}=5V, R_L=\infty$		3	6	mA
		$V_{CC}=15V, R_L=\infty$		7.5	15	mA
Initial Accuracy (Note 2)	$A_{CCUR}$	$R_A=1k \sim 100k\Omega$		1.0	3.0	%
				2.25		%
Drift with Temperature	$\Delta t/\Delta T$	$C=0.1\mu F$		50		ppm/ $^\circ C$
				150		ppm/ $^\circ C$
Drift with Supply Voltage	$\Delta t/\Delta V_{CC}$			0.1	0.5	%/V
				0.3		%/V
Control Voltage	$V_C$	$V_{CC}=15V$	9.0	10.0	11.0	V
		$V_{CC}=5V$	2.6	3.33	4.0	V
Threshold Voltage	$V_{TH}$	$V_{CC}=15V$		10.0		V
		$V_{CC}=5V$		3.33		V
Threshold Current (Note 3)	$I_{TH}$			0.1	0.25	$\mu A$
Trigger Voltage	$V_{TR}$	$V_{CC}=5V$	1.1	1.67	2.2	V
		$V_{CC}=15V$	4.5	5	5.6	V
Trigger Current	$I_{TR}$	$V_{TR}=0$		0.01	2.0	$\mu A$
Reset Voltage	$V_{RST}$		0.4	0.7	1.0	V
Reset Current	$I_{RST}$			0.1	0.4	mA
Low Output Voltage	$V_{OL}$	$V_{CC}=15V$				
		$I_{SINK}=10mA$		0.06	0.25	V
		$I_{SINK}=50mA$		0.3	0.75	V
		$V_{CC}=5V$				
High Output Voltage	$V_{OH}$	$V_{CC}=15V$				
		$I_{SOURCE}=200mA$		12.5		V
		$I_{SOURCE}=100mA$	12.75	13.3		V
		$V_{CC}=5V, I_{SOURCE}=100mA$	2.75	3.3		V
Rise Time of Output	$t_R$			100		ns
Fall Time of Output	$t_F$			100		ns
Discharge Leakage Current	$I_{LKG}$			20	100	nA

Note 1: Supply current when output high typically 1mA less at  $V_{CC}=5V$ .

Note 2: Tested at  $V_{CC}=5.0V$  and  $V_{CC}=15V$ .

Note 3: This will determine the maximum value of  $R_A+R_B$  for 15V operation, The maximum total is  $R=20M\Omega$ , and for 5V operation the maximum total is  $R=6.7M\Omega$ .

## ■ TYPICAL APPLICATION CIRCUIT

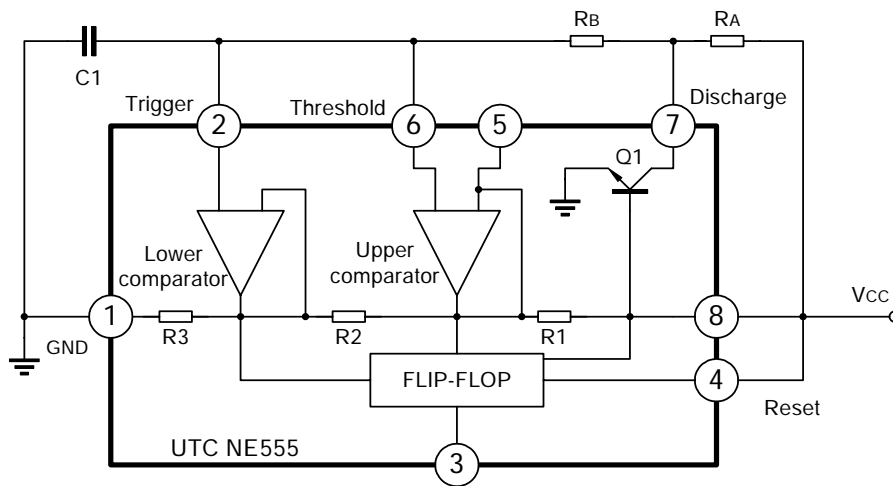

### ■ TYPICAL APPLICATION NOTES

The application circuit shows astable mode configuration.

Pin 6 (Threshold) is tied to Pin 2 (Trigger) and Pin 4 (reset) is tied to  $V_{CC}$  (Pin 8). The external capacitor  $C_1$  of Pin 6 and Pin 2 charges through  $R_A$ ,  $R_B$  and discharges through  $R_B$  only. In the internal circuit of UTC NE555, one input of the upper comparator is at voltage of  $\frac{2}{3}V_{CC}$  ( $R_1=R_2=R_3$ ), another input is connected to Pin 6. As soon as  $C_1$  is charging to higher than  $\frac{2}{3}V_{CC}$ , transistor  $Q_1$  is turned ON and discharge  $C_1$  to collector voltage of transistor  $Q_1$ . Therefore, the flip-flop circuit is reset and output is low. One input of lower comparator is at voltage of  $\frac{1}{3}V_{CC}$ , discharge transistor  $Q_1$  turn off and  $C_1$  charges through  $R_A$  and  $R_B$ . Therefore, the flip-flop circuit is set output high.

That is, when  $C_1$  charges through  $R_A$  and  $R_B$ , output is high and when  $C_1$  discharge through  $R_B$ , output is low. The charge time (output is high)  $t_1$  is  $0.693(R_A+R_B)C_1$  and the discharge time (output is low)  $T_2$  is  $0.693R_B C_1$ .

$$\ln \left( \frac{V_{CC} - \frac{1}{3}V_{CC}}{V_{CC} - \frac{2}{3}V_{CC}} \right) = 0.693$$

$$T_1 = 0.693(R_A + R_B)C_1$$

$$T_2 = 0.693R_B C_1$$

Thus the total period time  $T$  is given by

$$T = T_1 + T_2 = 0.693(R_A + 2R_B)C_1$$

Then the frequency of astable mode is given by

$$f = \frac{1}{T} = \frac{1.44}{(R_A + 2R_B)C_1}$$

The duty cycle is given by

$$\text{D.C.} = \frac{T_2}{T} = \frac{R_B}{R_A + 2R_B}$$

## TYPICAL CHARACTERISTICS

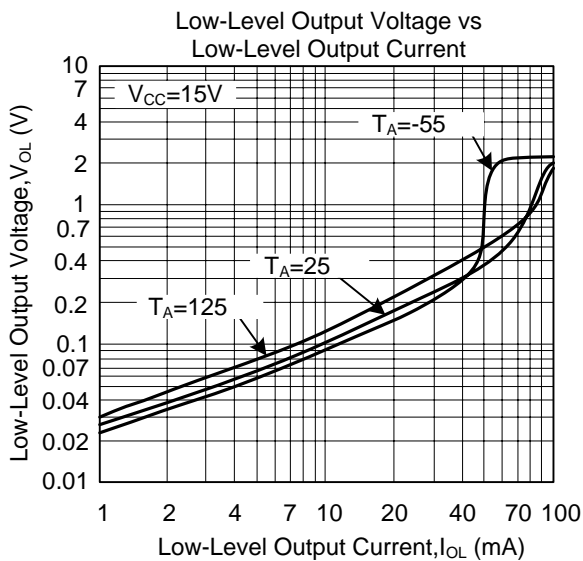
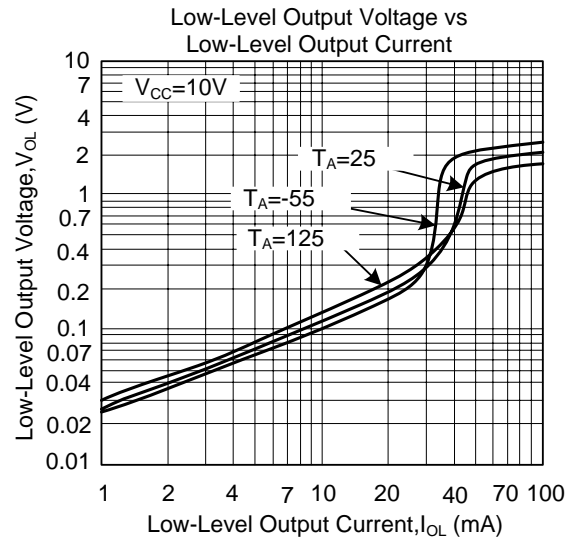
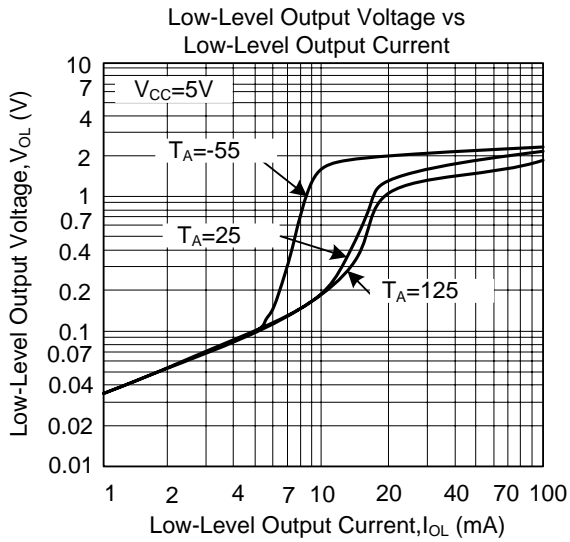
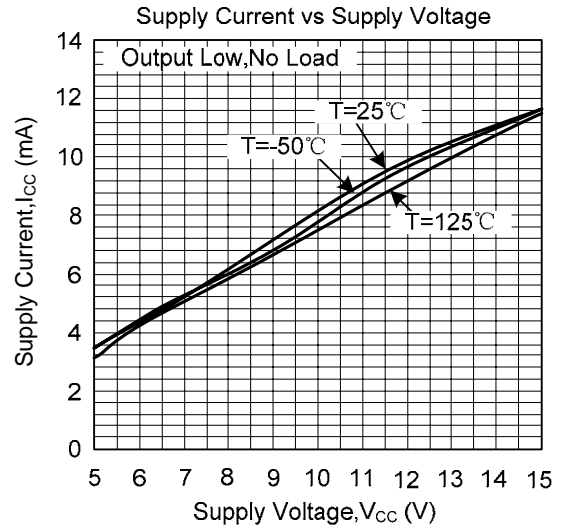
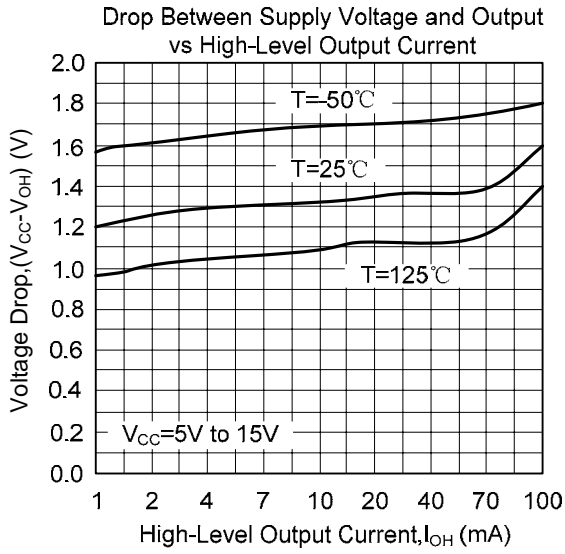

UTC assumes no responsibility for equipment failures that result from using products at values that exceed, even momentarily, rated values (such as maximum ratings, operating condition ranges, or other parameters) listed in products specifications of any and all UTC products described or contained herein. UTC products are not designed for use in life support appliances, devices or systems where malfunction of these products can be reasonably expected to result in personal injury. Reproduction in whole or in part is prohibited without the prior written consent of the copyright owner. The information presented in this document does not form part of any quotation or contract, is believed to be accurate and reliable and may be changed without notice.