



PZTA44/45

NPN SILICON TRANSISTOR

NPN HIGH VOLTAGE TRANSISTOR

■ FEATURES

- * Collector-emitter voltage:
 $V_{CE0}=400V$ (PZTA44)
 $V_{CE0}=350V$ (PZTA45)
- * Collector current up to 300mA
- * Complement to PZTA94/93

■ APPLICATION

- * Telephone switching
- * High voltage switch

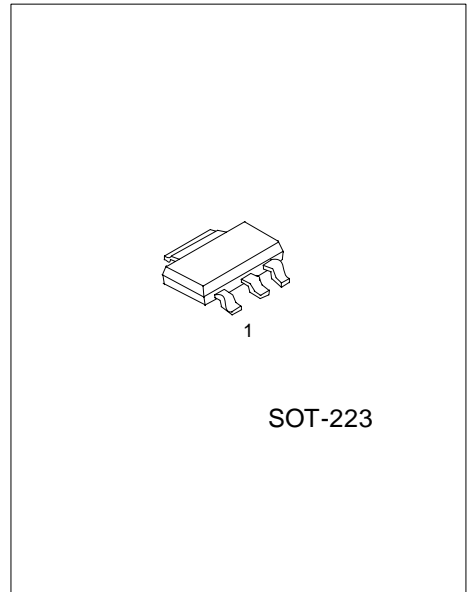

*Pb-free plating product number:
PZTA44L/PZTA45L

■ ORDERING INFORMATION

Order Number		Package	Pin Assignment			Packing
Normal	Lead Free Plating		1	2	3	
PZTA44-AA3-R	PZTA44L-AA3-R	SOT-223	B	C	E	Tape Reel
PZTA44-AA3-T	PZTA44L-AA3-T	SOT-223	B	C	E	Tube
PZTA45-AA3-R	PZTA45L-AA3-R	SOT-223	B	C	E	Tape Reel
PZTA45-AA3-T	PZTA45L-AA3-T	SOT-223	B	C	E	Tube

<p>PZTA44L-AA3-R</p> <p>(1)Packing Type (2)Package Type (3)Lead Plating</p>	<p>(1) R: Tape Reel, T: Tube (2) AA3: SOT-223 (3) L: Lead Free Plating, Blank: Pb/Sn</p>
---	--

PZTA44/45

NPN SILICON TRANSISTOR

■ ABSOLUTE MAXIMUM RATINGS (Ta=25°C, unless otherwise specified)

PARAMETER	SYMBOL	RATINGS	UNIT
Collector-Base Voltage	PZTA44	500	V
	PZTA45	400	V
Collector-Emitter Voltage	PZTA44	400	V
	PZTA45	350	V
Emitter-Base Voltage	V _{EBO}	6	V
Collector Current	I _C	300	mA
Collector Dissipation	P _C	1.2	W
Junction Temperature	T _J	+150	°C
Storage Temperature	T _{STG}	-55 ~ +150	°C

Note: Absolute maximum ratings are those values beyond which the device could be permanently damaged. Absolute maximum ratings are stress ratings only and functional device operation is not implied.

■ ELECTRICAL CHARACTERISTICS (T_J=25°C, unless otherwise specified)

PARAMETER	SYMBOL	TEST CONDITIONS	MIN	TYP	MAX	UNIT
Collector-Base Breakdown Voltage	PZTA44	I _C =100μA, I _B =0	500			V
	PZTA45					
Collector-Emitter Breakdown Voltage	PZTA44	I _C =1mA, I _B =0	400			V
	PZTA45					
Emitter-Base Breakdown Voltage	BV _{EBO}	I _E =100μA, I _C =0	6			V
Collector Cut-OFF Current	PZTA44	I _{CBO}	V _{CB} =400V, I _E =0		0.1	μA
	PZTA45					
Collector Cut-OFF Current	PZTA44	I _{CES}	V _{CE} =400V, I _B =0		0.5	μA
	PZTA45					
Emitter Cut-OFF Current	I _{EBO}	V _{EB} =4V, I _C =0			0.1	μA
DC Current Gain (Note)	h _{FE}	V _{CE} =10V, I _C =1mA	40			
		V _{CE} =10V, I _C =10mA	50		240	
		V _{CE} =10V, I _C =50mA	45			
		V _{CE} =10V, I _C =100mA	40			
Collector-Emitter Saturation Voltage	V _{CE(SAT)}	I _C =1mA, I _B =0.1mA			0.4	V
		I _C =10mA, I _B =1mA			0.5	V
		I _C =50mA, I _B =5mA			0.75	V
Base-Emitter Saturation Voltage	V _{BE(SAT)}	I _C =10mA, I _B =1mA			0.75	V
Current Gain Bandwidth Product	f _T	V _{CE} =20V, I _C =10mA, f=100MHz	50			MHz
Output Capacitance	C _{ob}	V _{CB} =20V, I _E =0, f=1MHz			7	pF

Note: Pulse test: Pulse Width<300μs, Duty Cycle<2%

TYPICAL CHARACTERISTICS

Fig.1 DC Current Gain

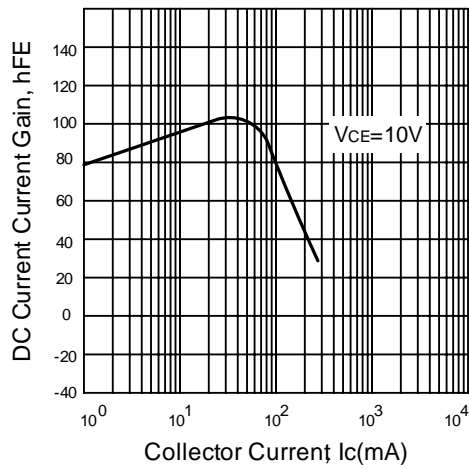

Fig.2 Turn-ON Switching Time

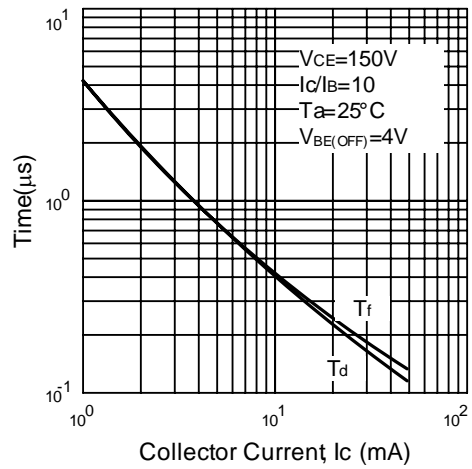

Fig.3 Turn-OFF Switching Time

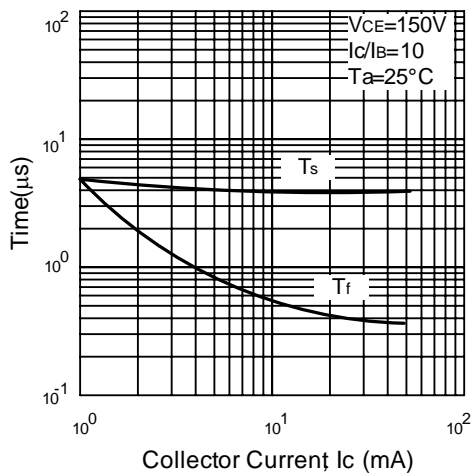

Fig.4 Capacitance

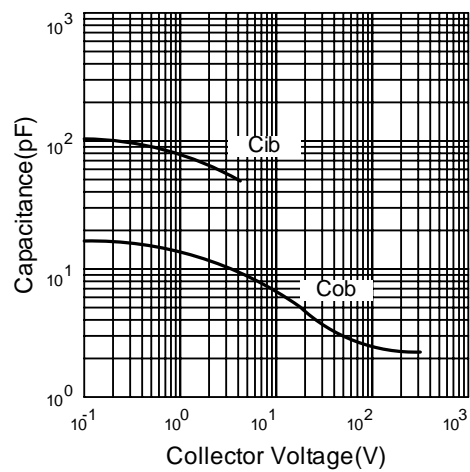

Fig.5 ON Voltage

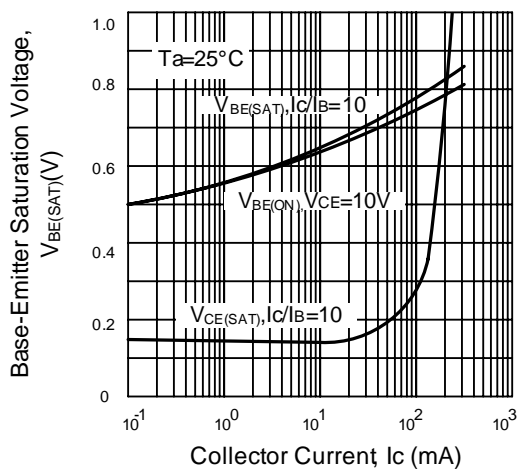
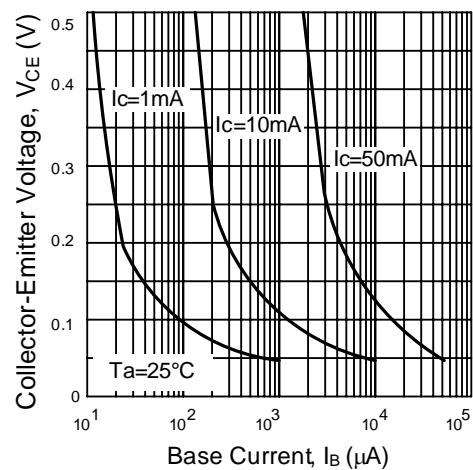

Fig.6 Collector Saturation Region



■ TYPICAL CHARACTERISTICS(Cont.)

Fig.7 High Frequency Current Gain

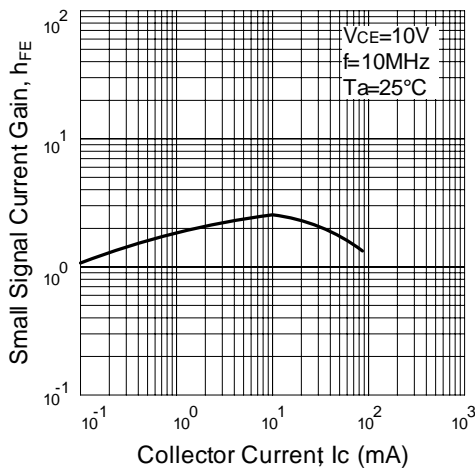
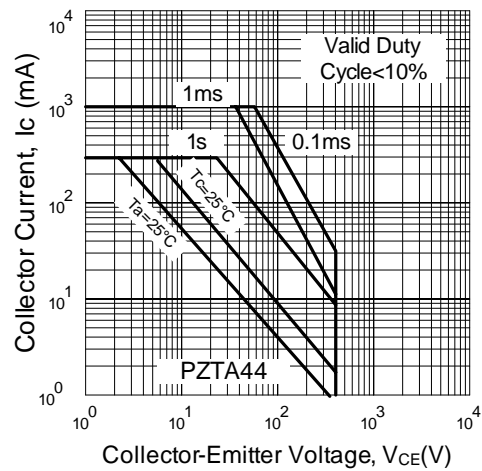

Fig.8 Safe Operating Area



UTC assumes no responsibility for equipment failures that result from using products at values that exceed, even momentarily, rated values (such as maximum ratings, operating condition ranges, or other parameters) listed in products specifications of any and all UTC products described or contained herein. UTC products are not designed for use in life support appliances, devices or systems where malfunction of these products can be reasonably expected to result in personal injury. Reproduction in whole or in part is prohibited without the prior written consent of the copyright owner. The information presented in this document does not form part of any quotation or contract, is believed to be accurate and reliable and may be changed without notice.