



RXXLD10

LINEAR INTEGRATED CIRCUIT

LOW VOLTAGE OPERATION LOW POWER-LOSS VOLTAGE REGULATORS

■ FEATURES

- * Operating under low voltage range (Minimum: 2.35V) input 2.5V, available output around 1.5 ~ 1.8V
- * Low dissipation current
- * Built-in overcurrent protection and over temperature protection functions

■ EQUIVALENT

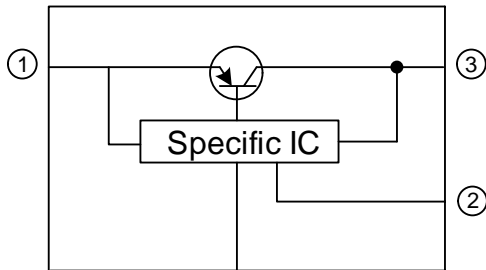

⑤ / ④ For TO-220F-4 Package

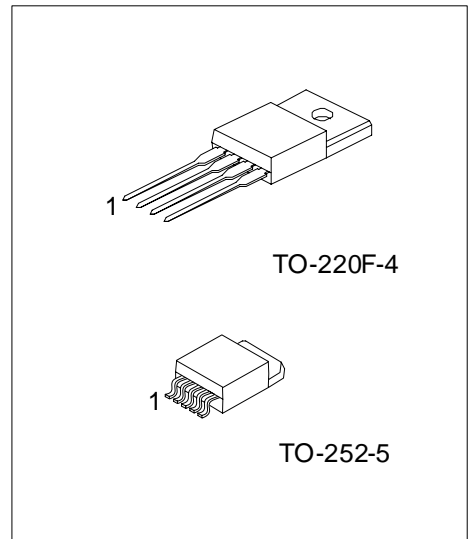

*Pb-free plating product number: RXXLD10L

■ ORDERING INFORMATION

Order Number		Package	Packing
Normal	Lead Free Plating		
RXXLD10-TF4-T	RXXLD10L-TF4-T	TO-220F-4	Tube
RXXLD10-TN5-R	RXXLD10L-TN5-R	TO-252-5	Tape Reel
RXXLD10-TN5-T	RXXLD10L-TN5-T	TO-252-5	Tube

<p>RXXLD10L-TF4-R</p>	<p>(1) Packing Type (2) Package Type (3) Lead Plating (4) Output Voltage Code</p> <p>(1) R: Tape Reel, T: Tube (2) TF4: TO-220F-4, TN5: TO-252-5 (3) L: Lead Free Plating, Blank: Pb/Sn (4) xx: refer to Marking Information</p>
-----------------------	--

■ PIN DESCRIPTION

PIN NO.		PIN NAME
TO-220F-4	TO-252-5	
1	1	INPUT
2	2	ON/OFF
3	3	OUTPUT
-	4	NC
4	5	GND

■ MARKING INFORMATION

PACKAGE	VOLTAGE CODE	MARKING
TO-220F-4	15:1.5V 18:1.8V 25:2.5V 03:3.0V 33:3.3V 05:5.0V	
TO-252-5		

■ ABSOLUTE MAXIMUM RATINGS (Ta = 25)

PARAMETER	SYMBOL	RATINGS	UNIT
Input Voltage	V _{IN}	10	V
ON/OFF Control Terminal Voltage (Note 2)	V _C	10	V
Output Current	I _{OUT}	1.0	A
Power Dissipation (with infinite heat sink)	P _D	8	W
Junction Temperature	T _J	+150	
Operating Temperature	T _{OPR}	-40 ~ +85	
Storage Temperature	T _{STG}	-40 ~ +150	

Note 1. Absolute maximum ratings are those values beyond which the device could be permanently damaged.

Absolute maximum ratings are stress ratings only and functional device operation is not implied.

2. All are open except GND and applicable terminals.

■ ELECTRICAL CHARACTERISTICS

(V_{IN} = V_{O(TYP)}+1V, I_{OUT} = 0.5A, V_C = 2.7V, Ta = 25 , unless otherwise specified.)

PARAMETER		SYMBOL	TEST CONDITIONS	MIN	TYP	MAX	UNIT
Input Voltage	R15LD10	V _{IN}		2.35		10	V
	R18LD10			2.35		10	V
	R25LD10			V _{OUT} +0.5		10	V
	R03LD10			V _{OUT} +0.5		10	V
	R33LD10			V _{OUT} +0.5		10	V
	R05LD10			V _{OUT} +0.5		10	V
Output Voltage	R15LD10	V _{OUT}		1.45	1.5	1.55	V
	R18LD10			1.75	1.8	1.85	V
	R25LD10			2.438	2.5	2.562	V
	R03LD10			2.925	3	3.075	V
	R33LD10			3.218	3.3	3.382	V
	R05LD10			4.875	5	5.125	V
Load Regulation		ΔV _{OUT}	I _{OUT} = 5mA ~ 1A		0.2	2	%
Line Regulation		ΔV _{OUT}	V _{IN} = V _{O(TYP)} +1V ~ V _{O(TYP)} +6V I _{OUT} = 5mA		0.1	1	%
Voltage for Control (Note 1)	ON	V _{C(ON)}		2			V
	OFF	V _{C(OFF)}				0.8	V
Current for Control	ON	I _{C(ON)}				200	μA
	OFF	I _{C(OFF)}	V _C = 0.4V			2	μA
Quiescent Current		I _Q	I _{OUT} = 0A		1	2	mA
Output Off-State Dissipation Current		I _{QS}	I _{OUT} = 0A, V _C = 0.4V			5	μA
Dropout Voltage (Note 2)		V _D	I _{OUT} = 1A		0.2	0.5	V
Temperature Coefficient of Output Voltage		T _C V _O	T _J = 0 ~ 125°C, I _{OUT} = 5mA		± 0.01		%/
Ripple Rejection		RR	Refer to Fig.2	45	60		dB

Note 1: In case of opening control terminal pin 2, output voltage turns off.

2: Input voltage shall be the value when output voltage is 95% in comparison with the initial value.

■ TEST CIRCUIT

TO-220F-4 Package:

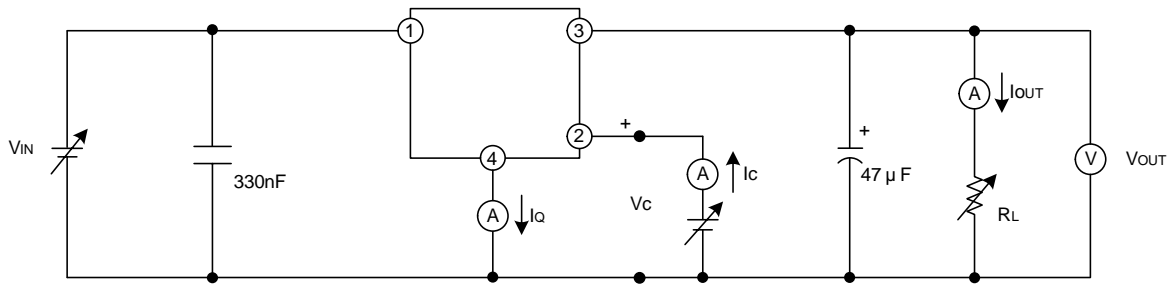

Fig.1

TO-252-5 Package:

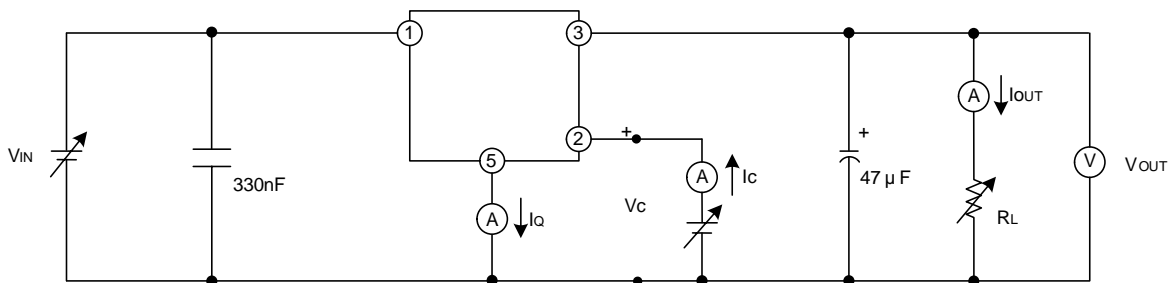
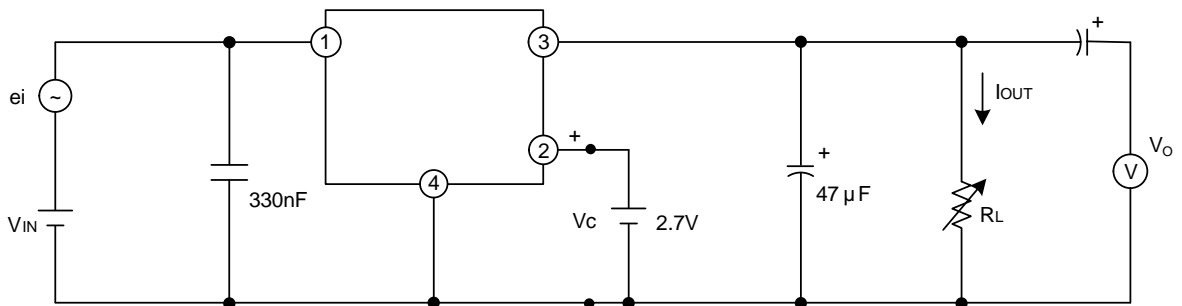

Fig.2

TO-220F-4 Package:



$f = 120\text{Hz}$ (sine wave), e_i (rms) = 0.5V , $V_{IN} = V_o$ (TYP)+ 2V , $I_{OUT} = 0.5\text{A}$, $RR = 20\log(e_i$ (rms) / V_o (rms))

Fig.3 For Ripple Rejection

TO-252-5 Package:

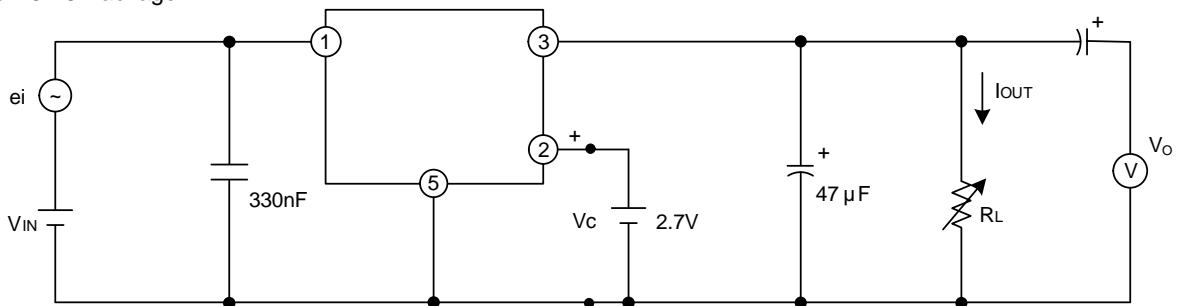

$f = 120\text{Hz}$ (sine wave), e_i (rms) = 0.5V , $V_{IN} = V_o$ (TYP)+ 2V , $I_{OUT} = 0.5\text{A}$, $RR = 20\log(e_i$ (rms) / V_o (rms))

Fig.4 For Ripple Rejection

■ TYPICAL APPLICATION CIRCUIT

TO-220F-4 Package:

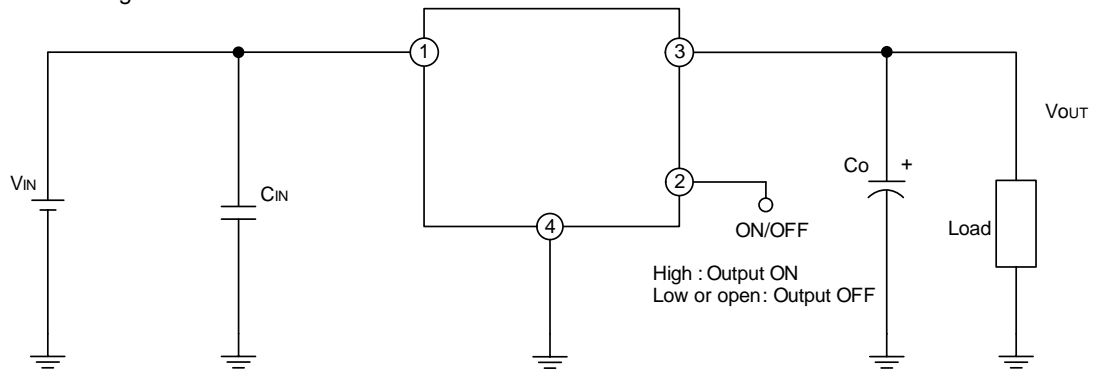

Fig. 5

TO-252-5 Package:

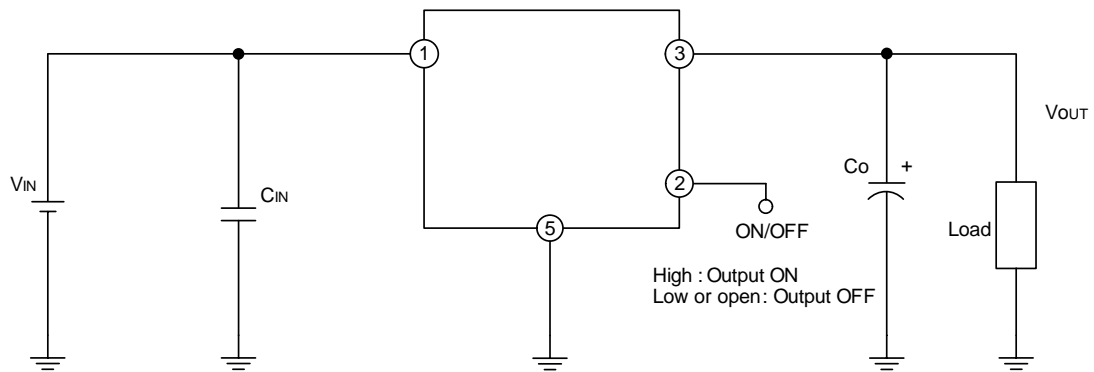
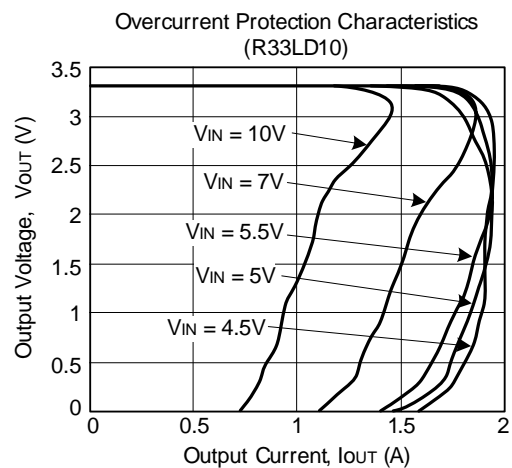
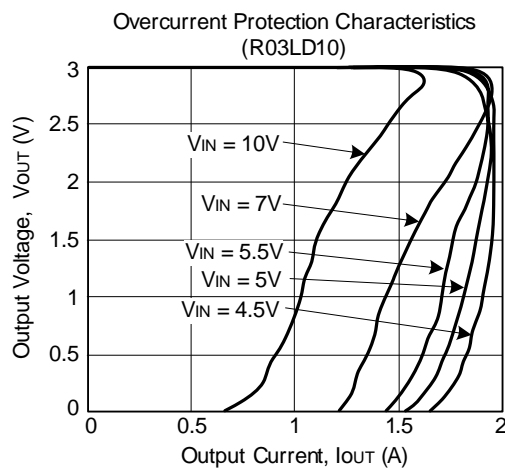
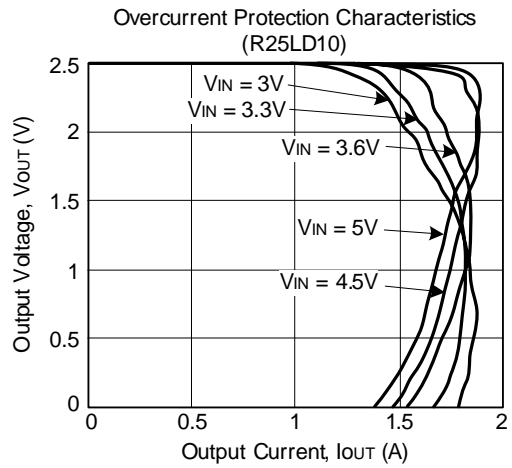
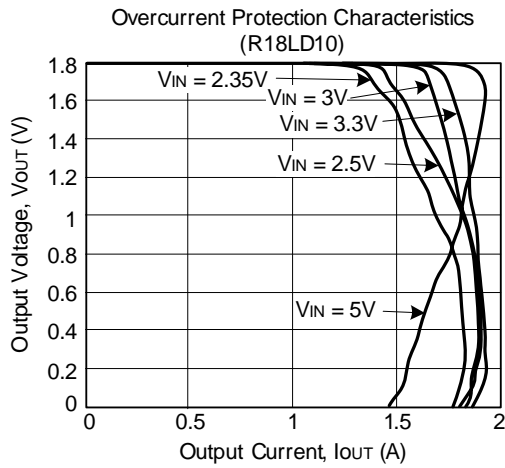
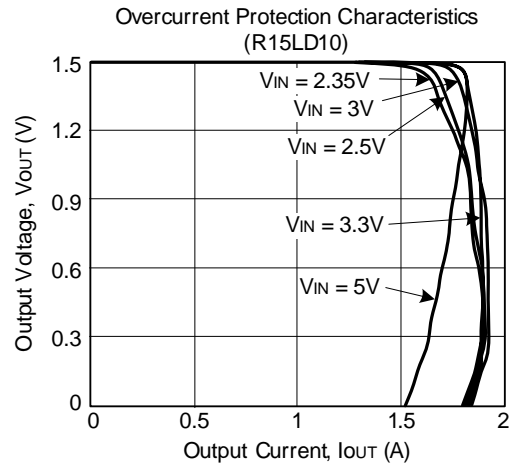
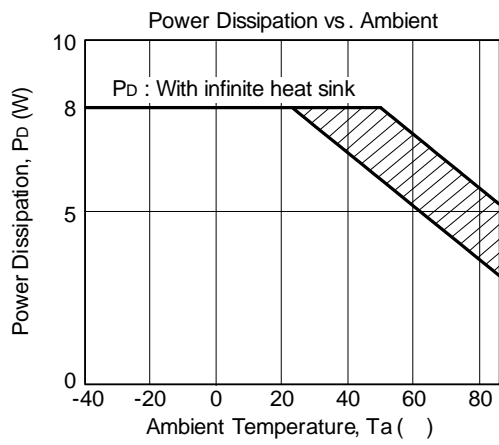
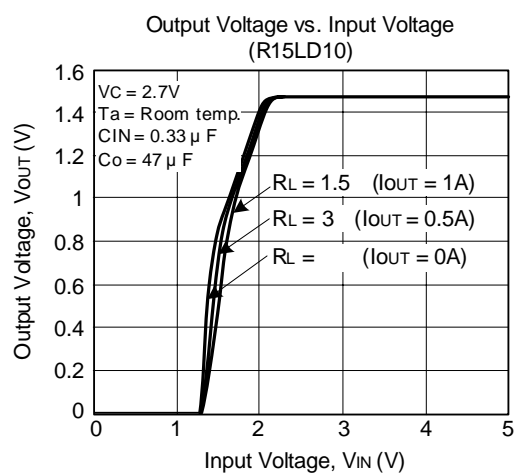
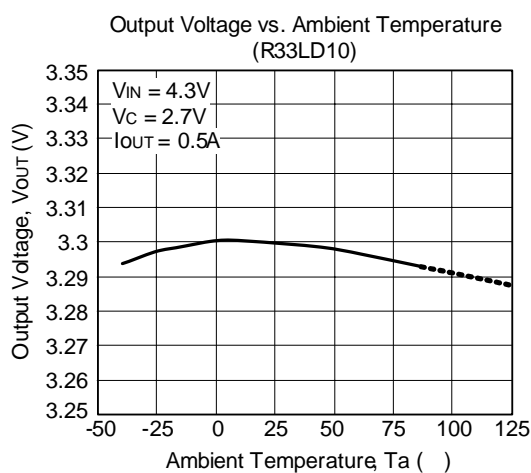
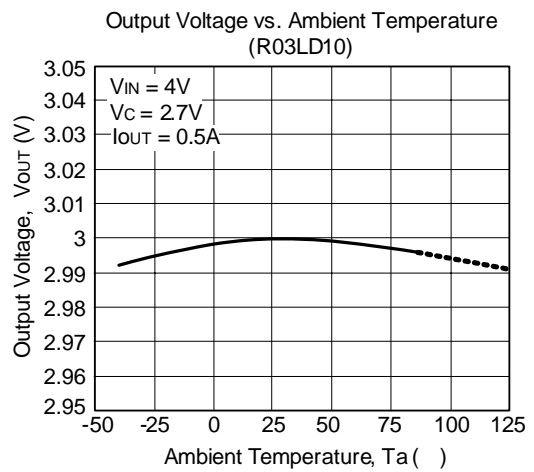
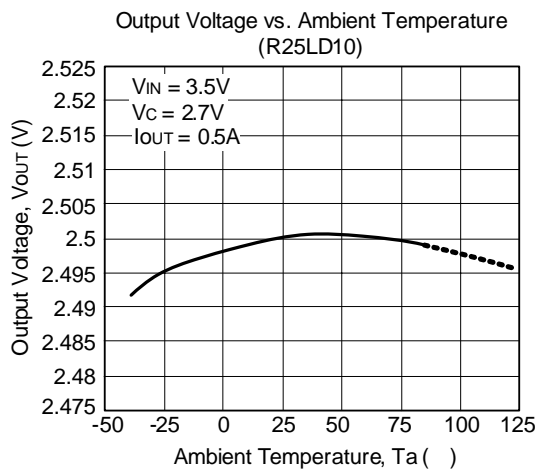
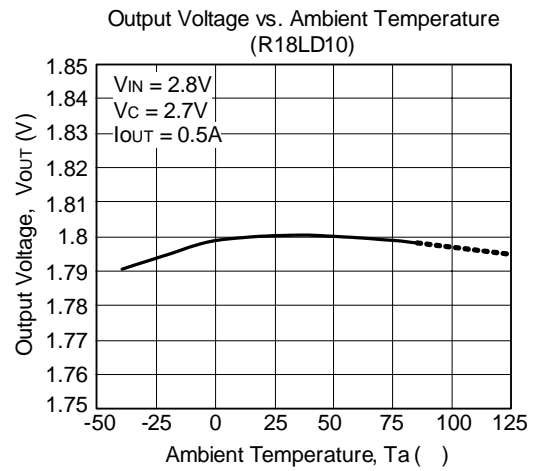
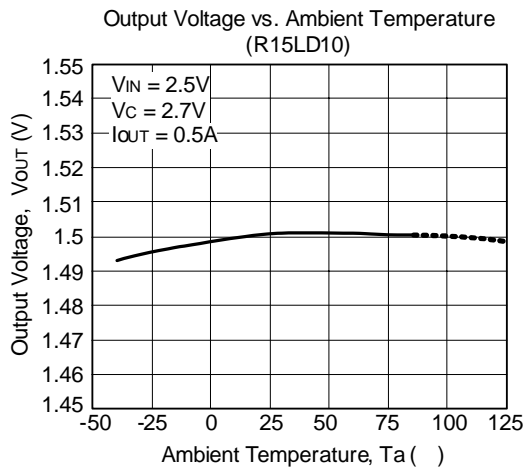

Fig. 6

TYPICAL CHARACTERISTICS



TYPICAL CHARACTERISTICS(Cont.)



TYPICAL CHARACTERISTICS(cont.)

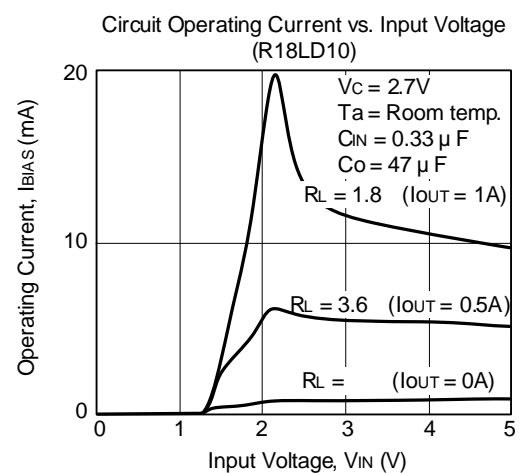
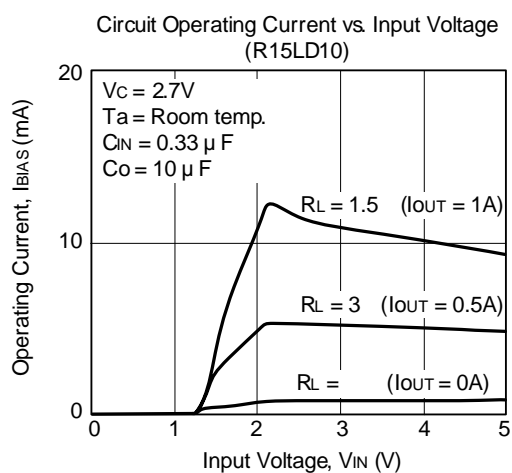
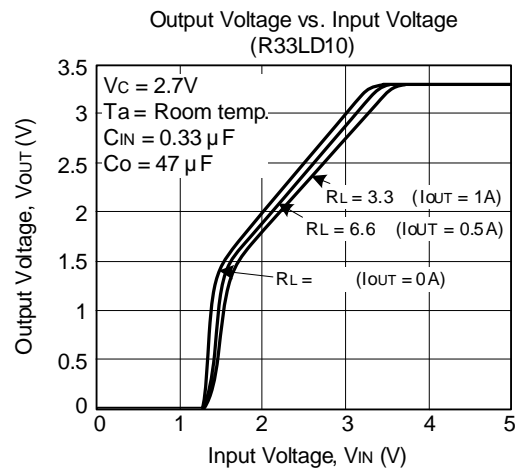
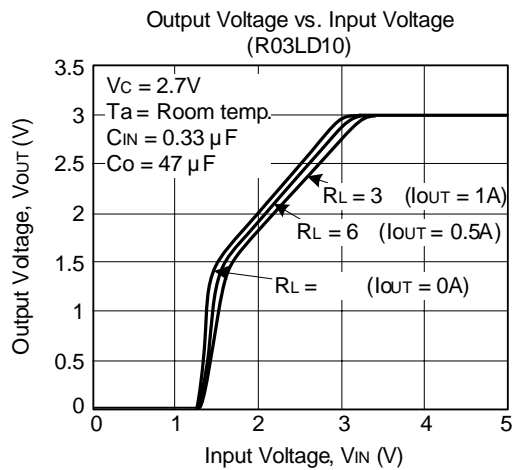
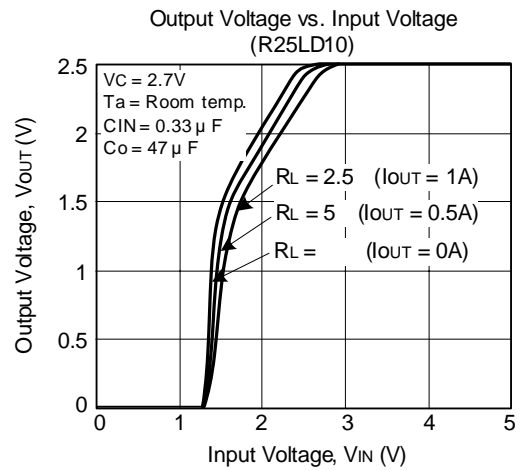
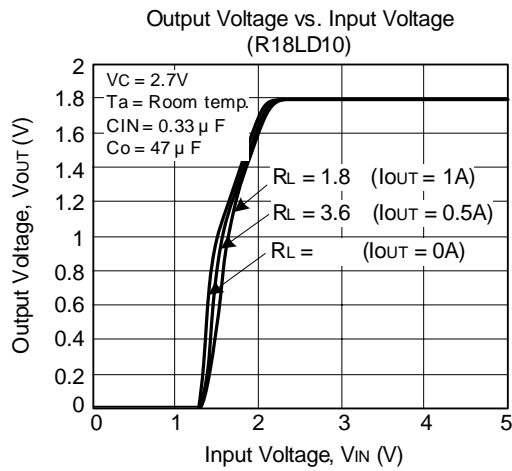

TYPICAL CHARACTERISTICS(Cont.)

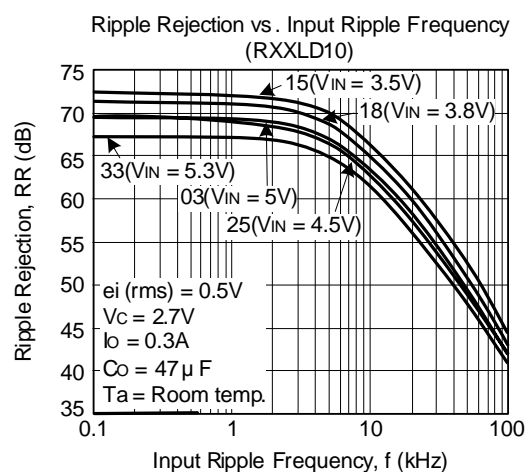
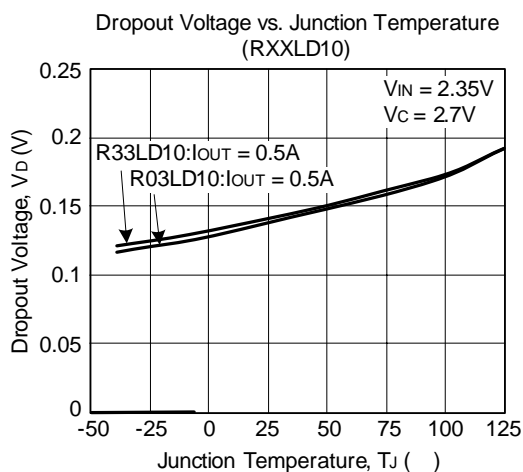
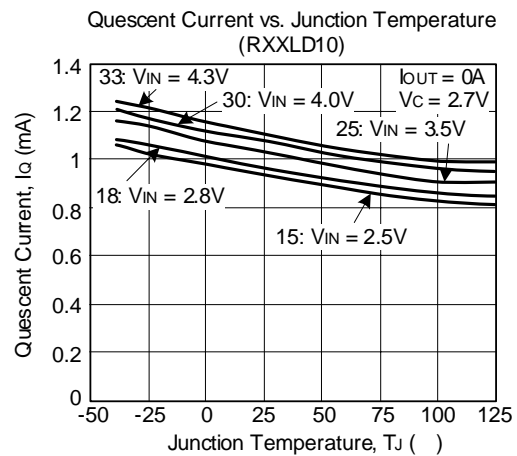
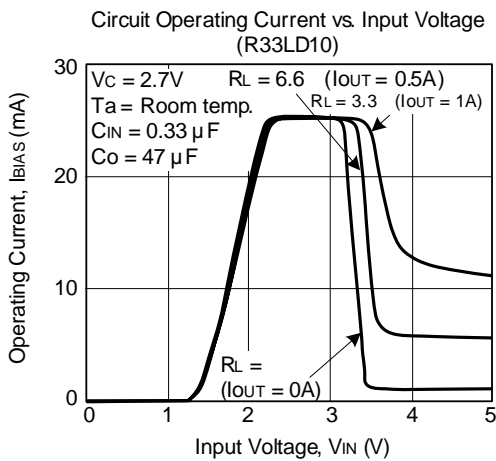
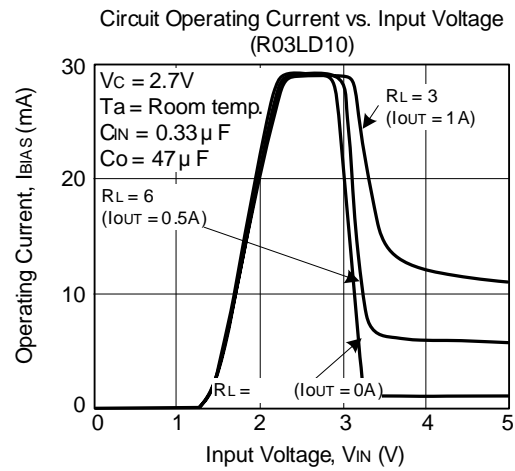
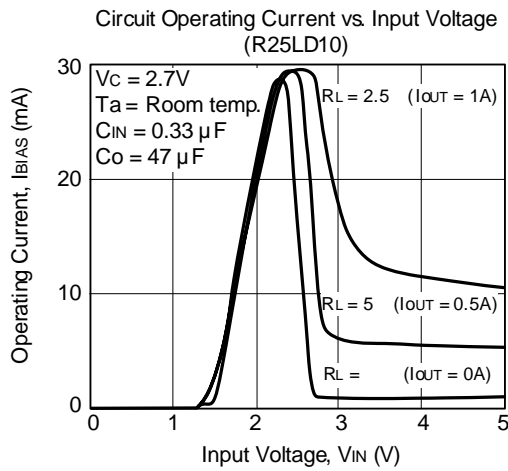

■ TYPICAL CHARACTERISTICS(Cont.)

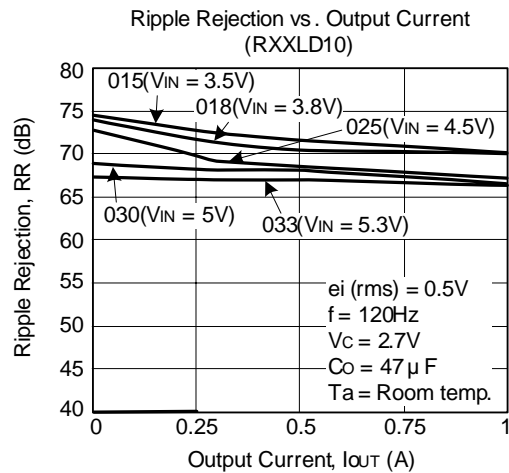

UTC assumes no responsibility for equipment failures that result from using products at values that exceed, even momentarily, rated values (such as maximum ratings, operating condition ranges, or other parameters) listed in products specifications of any and all UTC products described or contained herein. UTC products are not designed for use in life support appliances, devices or systems where malfunction of these products can be reasonably expected to result in personal injury. Reproduction in whole or in part is prohibited without the prior written consent of the copyright owner. The information presented in this document does not form part of any quotation or contract, is believed to be accurate and reliable and may be changed without notice.