

# UTC TA31001 LINEAR INTEGRATED CIRCUIT

## TELEPHONE TONE RINGER

### DESCRIPTION

The UTC TA31001 is a bipolar integrated circuit designed for telephone bell replacement. It can also be used as alarms or other alerting devices.

### FEATURES

- \*Designed for telephone bell replacement.
- \*Low current drain for multiple extension of lines.
- \*Adjustable 2-frequency tone.
- \*Adjustable warbling rate.
- \*Built-in hysteresis prevents false triggering and rotary dial 'CHIRPS'.
- \*Programmable for initiation voltage by simple external resistor.

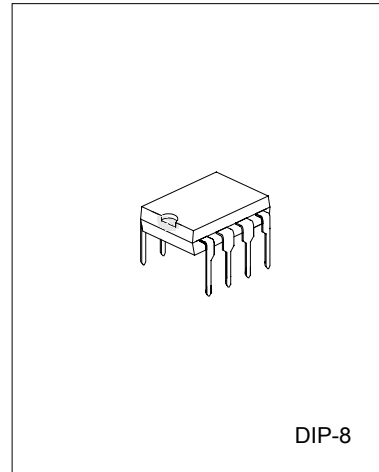

### BLOCK DIAGRAM

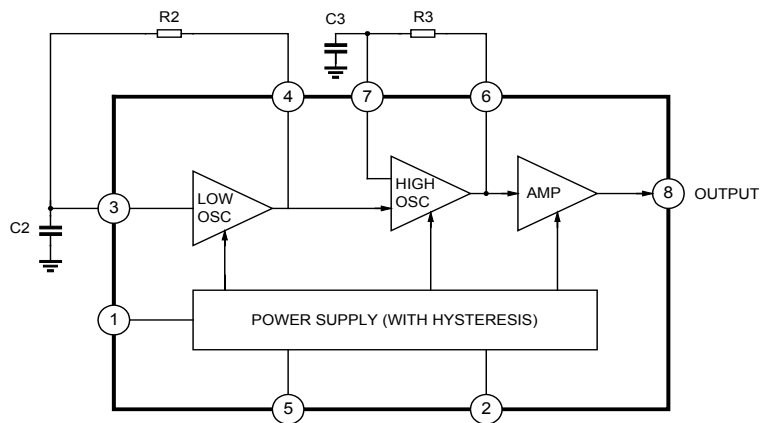

Note: R2, R3, C2 and C3 are parts externally mounted

# UTC TA31001 LINEAR INTEGRATED CIRCUIT

## ABSOLUTE MAXIMUM RATINGS(Ta=25°C )

PARAMETER	SYMBOL	VALUE	UNIT
Supply Voltage	V <sub>cc</sub>	30	V
Power Dissipation	P <sub>d</sub>	400	mW
Operating Temperature	T <sub>opr</sub>	-45 to 85	°C
Storage Temperature	T <sub>stg</sub>	-65 to 150	°C

## ELECTRICAL CHARACTERISTICS( Ta=25°C )

(All voltage referenced to GND unless otherwise specified)

PARAMETER	SYMBOL	TEST CONDITIONS	MIN	TYP	MAX	UNIT
Operating Supply Voltage	V <sub>cc</sub>				29	V
Initiation Supply Voltage (note 1)	V <sub>si</sub>	See Fig.1	17	19	21	V
Initiation Supply Current (note 1)	I <sub>si</sub>	6.8K-Pin 2 to GND	1.4	3.5	4.2	mA
Sustaining Voltage (note 2)	V <sub>sus</sub>	See Fig.1	9.7	11	12	V
Sustaining Current (note 2)	I <sub>sus</sub>	No Load V <sub>cc</sub> =V <sub>sus</sub> , See Fig.1	0.7	1.4	2.5	mA
Trigger Voltage (note 3)	V <sub>TRG</sub>	V <sub>cc</sub> =15V	9	10.5	12	V
Trigger Current (note 3)	I <sub>TRG</sub>	V <sub>cc</sub> =15V	10	20	1000 <sup>5</sup>	μA
Disable Voltage (note 4)	V <sub>DIS</sub>				0.8	V
Disable Current (note 4)	I <sub>DIS</sub>		-40	-50		μA
Output Voltage High	V <sub>OH</sub>	V <sub>cc</sub> =21V, I <sub>8</sub> =-15mA Pin6=6V, Pin7=GND	17.0	19	21	V
Output Voltage Low	V <sub>OL</sub>	V <sub>cc</sub> =21V, I <sub>8</sub> =15mA Pin6=GND, Pin7=6V			1.6	V
Input Current 1	I <sub>IN</sub> (Pin 3)	Pin3=6V, Pin4=GND			500	nA
Input Current 2	I <sub>IN</sub> (Pin 7)	Pin7=6V, Pin6=GND			500	nA
High Frequency 1	F <sub>H1</sub>	R3=191K, C3=6800pF	461	512	563	Hz
High Frequency 2	F <sub>H2</sub>	R3=191K, C3=6800pF	576	640	704	Hz
Low Frequency	F <sub>L</sub>	R2=165K, C2=0.47μF	9	10	11	Hz

\*NOTE (See electrical characteristics sheet)

1. Initiation supply voltage (V<sub>si</sub>) is the supply voltage required to start the tone ringer oscillating.
2. Sustaining voltage (V<sub>sus</sub>) is the supply voltage required to maintain oscillation.
3. V<sub>TR</sub> and I<sub>TR</sub> are the conditions applied to trigger in to start oscillation for V<sub>sus</sub> ≤ V<sub>cc</sub> ≤ V<sub>si</sub>
4. V<sub>DIS</sub> and I<sub>DIS</sub> are the conditions applied to trigger in to inhibit oscillation for V<sub>si</sub> ≤ V<sub>cc</sub>
5. Trigger current must be limited to this value externally.

# UTC TA31001 LINEAR INTEGRATED CIRCUIT

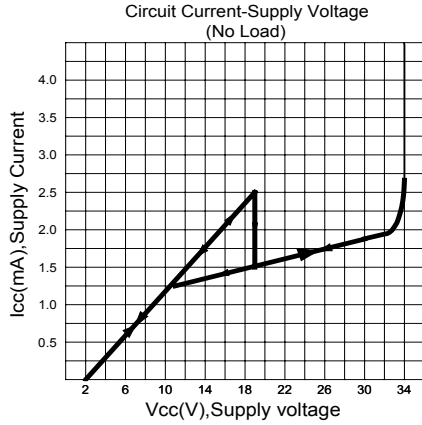

Fig. 1

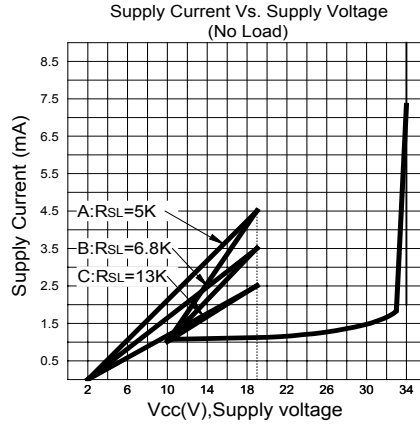

Fig. 2

## APPLICATION CIRCUIT

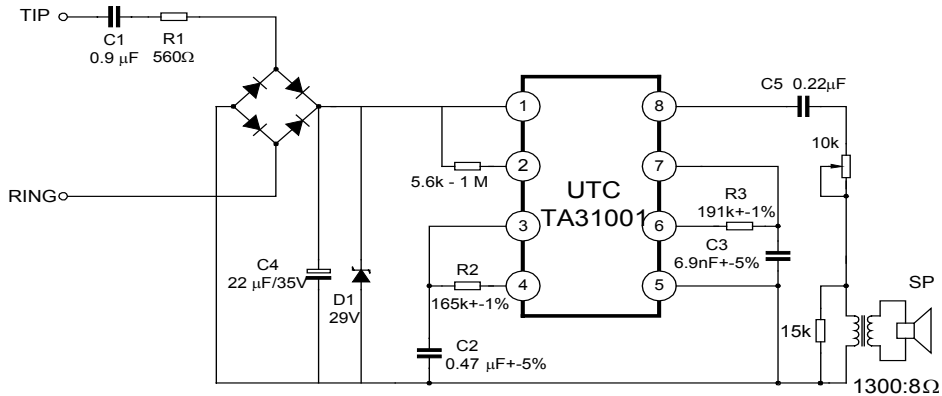

Fig. 3

UTC assumes no responsibility for equipment failures that result from using products at values that exceed, even momentarily, rated values (such as maximum ratings, operating condition ranges, or other parameters) listed in products specifications of any and all UTC products described or contained herein. UTC products are not designed for use in life support appliances, devices or systems where malfunction of these products can be reasonably expected to result in personal injury. Reproduction in whole or in part is prohibited without the prior written consent of the copyright owner. The information presented in this document does not form part of any quotation or contract, is believed to be accurate and reliable and may be changed without notice.