



## TF202

## N-CHANNEL JFET

### N-CHANNEL JFET CAPACITOR MICROPHONE APPLICATIONS

#### DESCRIPTION

The UTC **TF202** uses advanced trench technology to provide excellent  $R_{DS(ON)}$ , low gate charge and operation with low gate voltages. This device is suitable for use in capacitor microphone applications.

#### FEATURES

- \*Suited for use in audio, telephone capacitor microphones.
- \*Good voltage characteristic.
- \*Good transient characteristic.

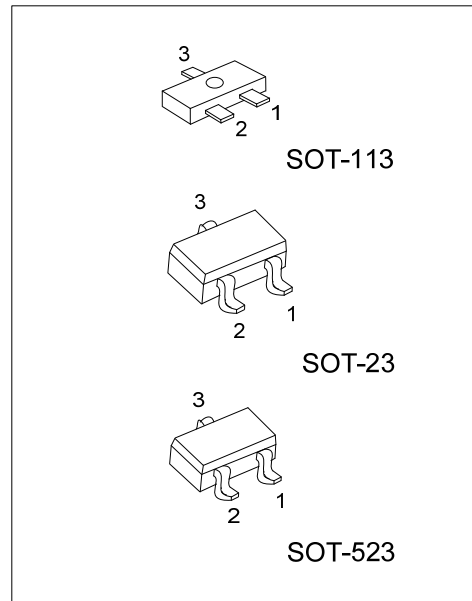

#### ORDERING INFORMATION

Ordering Number			Package	Pin Assignment			Packing
Normal	Lead Free	Halogen Free		1	2	3	
TF202-x-AC3-R	TF202L-x-AC3-R	TF202G-x-AC3-R	SOT-113	S	D	G	Tape Reel
TF202-x-AE3-R	TF202L-x-AE3-R	TF202G-x-AE3-R	SOT-23	S	D	G	Tape Reel
TF202-x-AN3-R	TF202L-x-AN3-R	TF202G-x-AN3-R	SOT-523	S	D	G	Tape Reel

<p>TF202L-x-AC3-R</p>	<p>(1) R: Tape Reel  (2) AC3: SOT-113, AE3: SOT-23, AN3: SOT-523  (3) x: refer to CLASSIFICATION OF <math>I_{DSS}</math>  (4) G: Halogen Free, L: Lead Free</p>
-----------------------	---

#### MARKING

TF202-E4	TF202-E5	TF202-E6

■ ABSOLUTE MAXIMUM RATINGS ( Ta=25°C, unless otherwise specified )

PARAMETER	SYMBOL	RATING	UNIT
Gate Drain Voltage	$V_{GDO}$	-20	V
Gate Current	$I_G$	10	mA
Drain Current	$I_D$	1	mA
Power Dissipation	$P_D$	100	mW
Junction Temperature	$T_J$	150	°C
Storage Temperature	$T_{STG}$	-55~+150	°C

Note: Absolute maximum ratings are those values beyond which the device could be permanently damaged. Absolute maximum ratings are stress ratings only and functional device operation is not implied.

■ ELECTRICAL CHARACTERISTICS ( Ta=25°C, unless otherwise specified)

PARAMETER	SYMBOL	TEST CONDITIONS	MIN	TYP	MAX	UNIT
Gate Drain Breakdown Voltage	$BV_{GDO}$	$I_G=-100\mu A$	-20			V
Gate Source Cut off Voltage	$V_{GS(OFF)}$	$V_{DS}=5V, I_D=1\mu A$	-0.2	-0.6	-1.2	V
Drain Current	$I_{DSS}$	$V_{DS}=5V, V_{GS}=0$	140		500	$\mu A$
Forward Transfer Admittance	$Y_{FSI}$	$V_{DS}=5V, V_{GS}=0, f=1KHz$	0.5	1.2		mS
Input Capacitance	$C_{ISS}$	$V_{DS}=5V, V_{GS}=0, f=1MHz$		3.5		pF
Output Capacitance	$C_{RSS}$	$V_{DS}=5V, V_{GS}=0, f=1MHz$		0.65		pF
Voltage Gain	$G_V$	$V_{IN}=10mV, f=1KHz$		-3		dB
Reduced Voltage Characteristic	$\Delta G_{VV}$	$V_{IN}=10mV, f=1KHz, V_{CC}=4.5V \rightarrow 1.5V$		-1.2	-3.5	dB
Frequency Characteristic	$\Delta G_{Vf}$	$f=1KHz$ to 110Hz			-1	dB
Input Resistance	$Z_{IN}$	$f=1KHz$	25			$M\Omega$
Output Resistance	$Z_O$	$f=1KHz$			700	$\Omega$
Total Harmonic distortion	THD	$V_{IN}=30mV, f=1KHz$		1		%
Output Noise Voltage	$V_{NO}$	$V_{IN}=0$			-110	dB

■ CLASSIFICATION OF  $I_{DSS}$

RANK	E4	E5	E6
RANGE	140-240	210-350	320-500

■ TEST CIRCUIT(Ta=25°C)

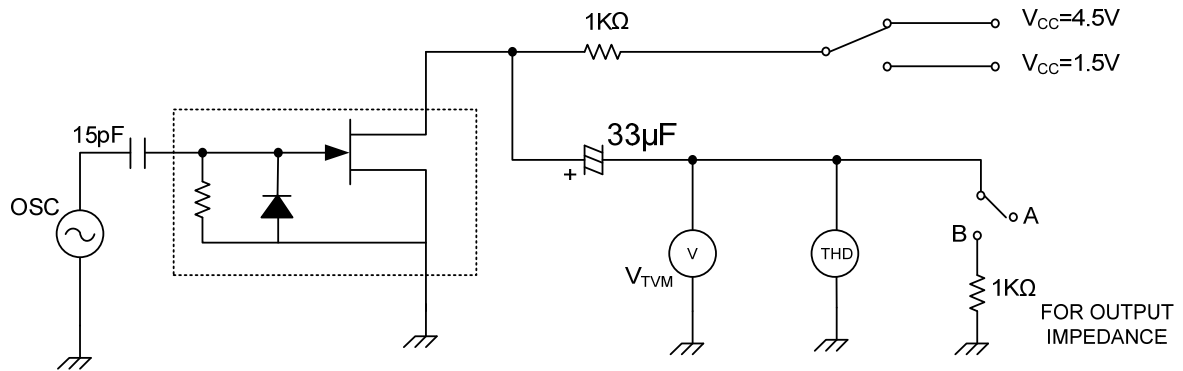

■ TYPICAL CHARACTERISTICS

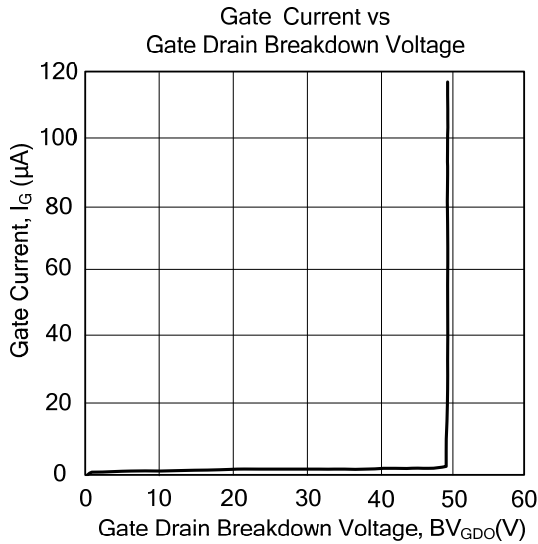
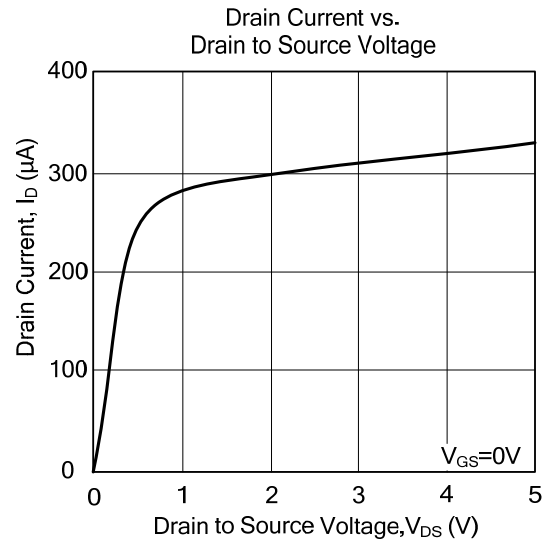
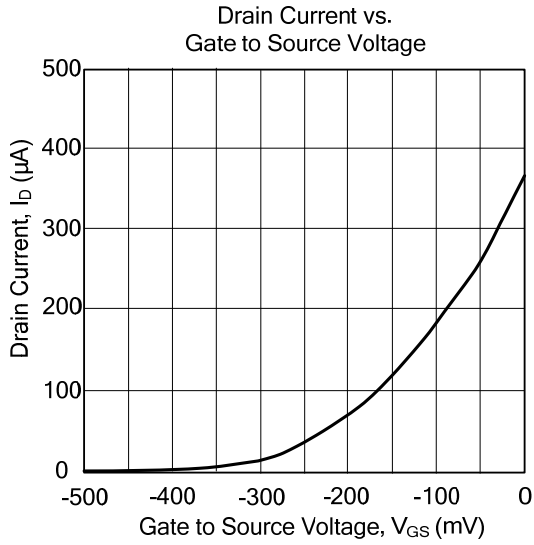

UTC assumes no responsibility for equipment failures that result from using products at values that exceed, even momentarily, rated values (such as maximum ratings, operating condition ranges, or other parameters) listed in products specifications of any and all UTC products described or contained herein. UTC products are not designed for use in life support appliances, devices or systems where malfunction of these products can be reasonably expected to result in personal injury. Reproduction in whole or in part is prohibited without the prior written consent of the copyright owner. The information presented in this document does not form part of any quotation or contract, is believed to be accurate and reliable and may be changed without notice.