



2.4V, 10uA ANALOG TEMPERATURE SENSOR

DESCRIPTION

The UTC **TS20** is a low-power analog precision output temperature sensor that operates over a supply voltage range from 2.4V to 5.5V, with a current consumption of only 10µA (max).

This device is particularly well suited for portable applications because minimizing battery cost and maximizing useful battery life are crucial.

The UTC **TS20** provides an analog voltage output proportional to temperature. Accuracy is ±1.5°C (max) at an ambient temperature of +30°C. The temperature error increases linearly and reaches a maximum of ±2.5°C at the temperature range extremes. Self-heating effects are negligible (less than 0.02°C in still air) due to the low current consumption.

The operating temperature range varies with the voltage supply. The UTC **TS20** can be used over a range of -55°C to +130°C with a supply voltage of 2.7V to 5.5V. For applications with a supply voltage of 2.4V, the UTC **TS20** can be used over a temperature range of -30°C to +130°C.

FEATURES

- * Power Supply Voltage: 2.4V ~ 5.5V
- * 2.5°C Accuracy
- * 10uA MAX. Current Consumption
- * Temperature Range -55°C to +130°C
- * Predictable Curvature Error
- * Suitable for Remote Applications

ORDERING INFORMATION

Ordering Number		Package	Pin Assignment					Packing
Lead Free	Halogen Free		1	2	3	4	5	
TS20L-AF5-R	TS20G-AF5-R	SOT-25	N	G	O	V _{CC}	G	Tape Reel

Note: Pin assignment: I:V_{IN} O:V_{OUT} G:GND N: No Connection

<p>TS20L-AF5-R</p> <p>(1) Packing Type (2) Package Type (3) Lead Free</p>	<p>(1) R: Tape Reel (2) AF5: SOT-25 (3) G: Halogen Free, L: Lead Free</p>
---	---

MARKING

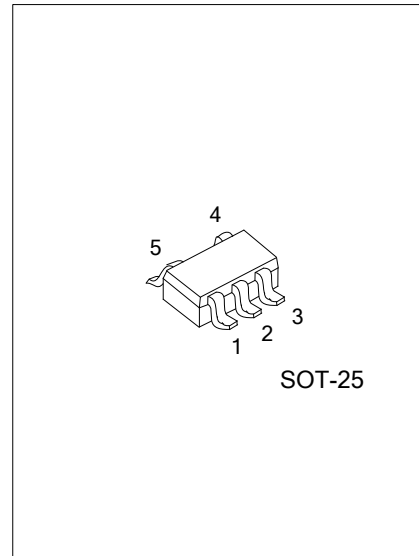
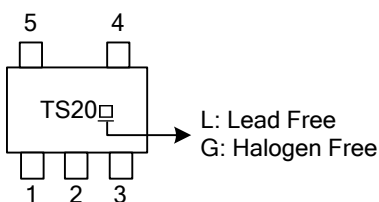

■ PIN CONFIGURATIONS

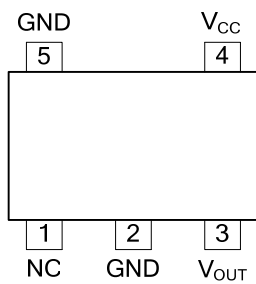

■ PIN DESCRIPTION

PIN	NAME	TYPE	PIN DESCRIPTION
1	NC	—	No Connection. (Must be connected to ground or left floating)
2	GND	I/O	Ground. (Should be connected to pin 5. May be left floating, if desired)
3	V _{OUT}	O	Voltage Output.
4	V _{CC}	I	Supply Voltage. (Bypass to GND with a 0.1uF capacitor)
5	GND	I/O	Ground.

■ BLOCK DIAGRAM

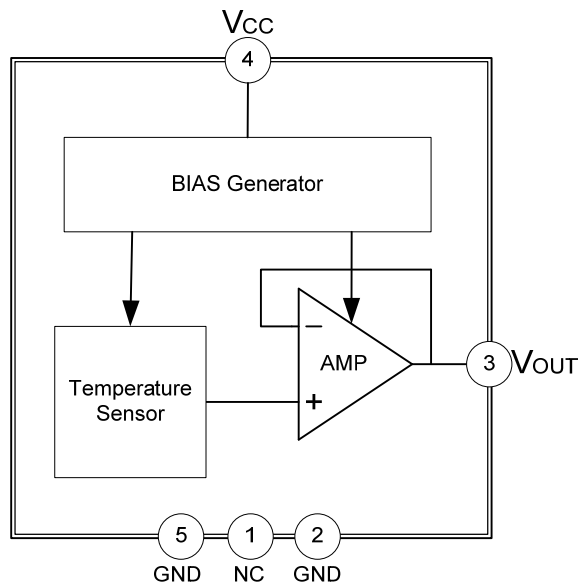

■ ABSOLUTE MAXIMUM RATING (unless otherwise specified)

PARAMETER	SYMBOL	RATINGS	UNIT
Power Supply Voltage	V _{CC}	-0.2 ~ +6.5	V
Output Voltage	V _{OUT}	-0.6 ~ (V _{CC} +0.6)	V
Output Current	I _{OUT}	10	mA
Input Current at any pin	I _{IN}	5	mA
Junction Temperature	T _J	+150	°C
Operating Temperature	T _{OPR}	-55 ~ +130	°C
Storage Temperature	T _{STG}	-65 ~ +150	°C

Note: Absolute maximum ratings are those values beyond which the device could be permanently damaged.
 Absolute maximum ratings are stress ratings only and functional device operation is not implied.

■ THERMAL DATA

PARAMETER	SYMBOL	RATINGS	UNIT
Junction to Ambient	θ _{JA}	415	°C/W

■ RECOMMENDED OPERATING CONDITIONS (unless otherwise specified)

PARAMETER	SYMBOL	MIN	TYP	MAX	UNIT
Power Supply Voltage	V _{CC}	2.4		5.5	V

■ ELECTRICAL CHARACTERISTICS (unless otherwise specified)

(V_{CC}=+2.7V, T_A = -55°C to +130°C. Typical values are at T_A = +25°C)

PARAMETER	SYMBOL	TEST CONDITIONS	MIN	TYP	MAX	UNIT	
Temperature-to-Voltage Error (Notes1,2)		T _A =+25°C~ +30°C	-1.5		+1.5	°C	
		T _A =+130°C	-2.5		+2.5	°C	
		T _A =+125°C	-2.5		+2.5	°C	
		T _A =+100°C	-2.2		+2.2	°C	
		T _A =+85°C	-2.1		+2.1	°C	
		T _A =+80°C	-2.0		+2.0	°C	
		T _A =0°C	-1.9		+1.9	°C	
		T _A =-30°C	-2.2		+2.2	°C	
		T _A =-40°C	-2.3		+2.3	°C	
		T _A =-55°C	-2.5		+2.5	°C	
Output Voltage	V _{OUT}	T _A = 0°C		1.8639		V	
Nonlinearity (Note3)		T _A = -20°C ~ +100°C		±0.4		%	
Variance from Curve				±1.0		°C	
Sensor Gain (Temperature Sensitivity or Average Slope) (Note4)		T _A = -30°C ~+100°C	-11.4	-11.77	-12.2	mV/°C	
Output Impedance	R _{OUT}	I _L =0uA ~ +16uA			160	Ω	
Load Regulation (Note5)	REG _{LOAD}	I _L =0uA ~ +16uA			-2.5	mV	
Line Regulation (Note6)	REG _{LINE}	V _{CC} =+2.4V ~ +5.0V			+3.3	mV/V	
		V _{CC} =+5.0V ~ +5.5V			+8.8	mV	
Quiescent Current	No Load	I _Q	V _{CC} =+2.4V ~ +5.5V		4.5	7	uA
			V _{CC} =+2.4V ~ +5.0V		4.5	10	uA
			V _{CC} =+2.4V ~ +5.5V		+0.7		uA
Change							
Temperature Coefficient of Quiescent Current	TC _{IQ}			-11		nA/°C	
Power-Down Supply Current	I _{SD}	V _{CC} ≤+0.8V		0.02		uA	

■ ELECTRICAL CHARACTERISTICS (Cont.)

Note1: $V_{OUT} = (-3.88 \times 10^{-6} \times T^2) + (-1.15 \times 10^{-2} \times T) + 1.8639V$ (T = temperature in degrees Celsius)

Note2: Accuracy is defined as the error between the measured and calculated output voltage at the specified conditions of voltage, current, and temperature (expressed in °C).

Note3: Nonlinearity is defined as the deviation of the calculated output-voltage-versus-temperature curve from the best-fit straight line, over the temperature range specified.

Note4: Linear Equation: $V_{OUT} = -11.77 \text{ mV/}^\circ\text{C} \times T + 1.860V$

Note5: Load regulation or output impedance specifications apply over the supply voltage range of +2.4V to +5.5V.

Note6: Line regulation is calculated by subtracting the output voltage at the highest supply input voltage from the output voltage at the lowest supply input voltage.

■ TYPICAL APPLICATIONS CIRCUITS

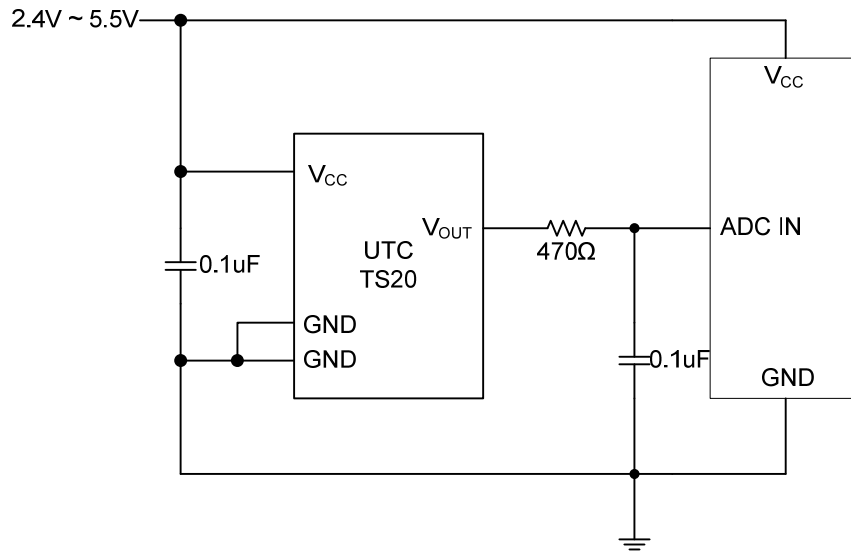

Note: $V_{OUT} = (-3.88 \cdot 10^{-6} \cdot T^2) + (-1.15 \cdot 10^{-2} \cdot T) + 1.8639$ (T=temperature in degrees Celsius)

$$\text{or } T = -1481.96 + \sqrt{2.1962 \cdot 10^6 + \frac{(1.8639 - V_{OUT})}{3.88 \cdot 10^6}}$$

Temperature(T)	Typical V_{OUT}
+130°C	303mV
+100°C	675mV
+80°C	919mV
+30°C	1515mV
+25°C	1574mV

Temperature(T)	Typical V_{OUT}
0°C	1863.9mV
-30°C	2205mV
-40°C	2318mV
-55°C	2485mV

■ TYPICAL CHARACTERISTICS($V_{CC}=+2.7V$, $T_A=25^{\circ}C$, unless otherwise specified)

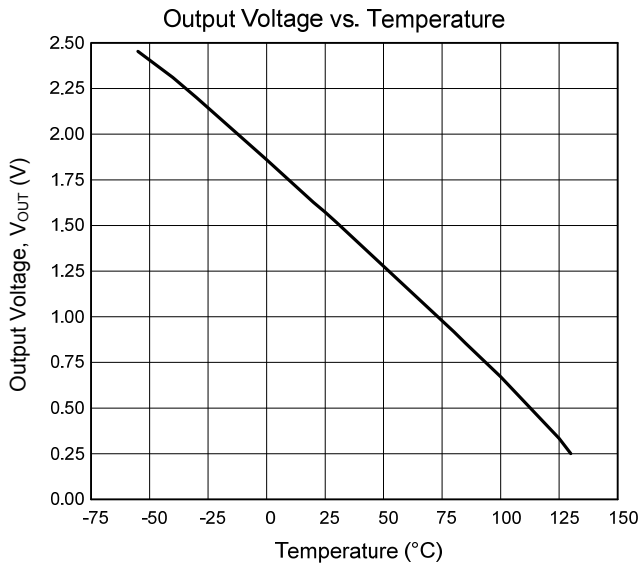

UTC assumes no responsibility for equipment failures that result from using products at values that exceed, even momentarily, rated values (such as maximum ratings, operating condition ranges, or other parameters) listed in products specifications of any and all UTC products described or contained herein. UTC products are not designed for use in life support appliances, devices or systems where malfunction of these products can be reasonably expected to result in personal injury. Reproduction in whole or in part is prohibited without the prior written consent of the copyright owner. The information presented in this document does not form part of any quotation or contract, is believed to be accurate and reliable and may be changed without notice.