

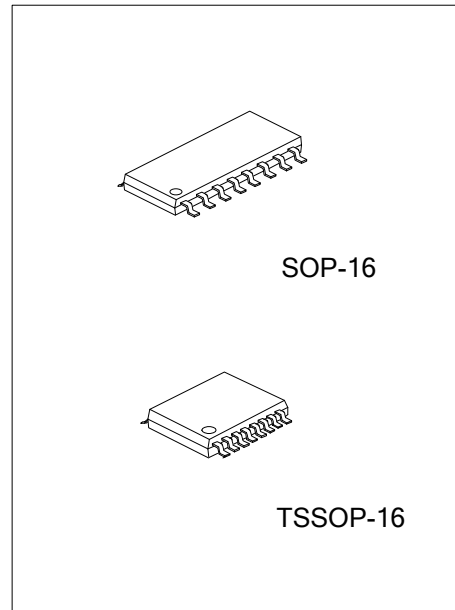

U74HC595A

CMOS IC

8-BIT SERIAL-IN SHIFT REGISTER WITH LATCHED 3-STATE PARALLEL OUTPUTS, PROVIDING SERIAL OUTPUT



DESCRIPTION

The UTC **74HC595A** contains an 8-bit register with asynchronous reset input and an 8-bit latch with output. The Serial Data Input (A) will shift into the internal shift register during every LOW-to-HIGH transition on the Shift Clock. The latch will latch the 8-bit data from the shift register during the LOW-to-HIGH transition on the Latch Clock. The shift register also provides a serial output.

FEATURES

- * Operation Voltage Range:2~6V
- * High Noise Immunity
- * Output Compatibility with CMOS and TTL
- * Specified from -40~+125°C

ORDERING INFORMATION

Ordering Number		Package	Packing
Lead Free	Halogen Free		
U74HC595AL-S16-R	U74HC595AG-S16-R	SOP-16	Tape Reel
U74HC595AL-P16-R	U74HC595AG-P16-R	TSSOP-16	Tape Reel

<p>U74HC595AL-S16-R</p> <p>(1) Packing Type</p> <p>(2) Package Type</p> <p>(3) Lead Free</p>	<p>(1) R: Tape Reel</p> <p>(2) S16: SOP-16, P16: TSSOP-16</p> <p>(3) G: Halogen Free, L: Lead Free</p>
--	--

■ PIN CONFIGURATION

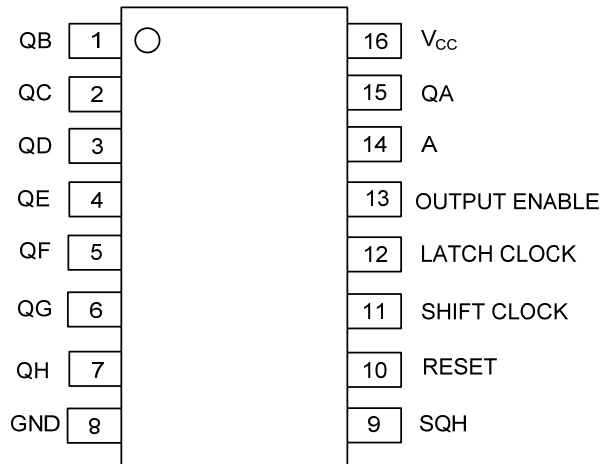

■ FUNCTION TABLE

Operation	INPUT					OUTPUT			
	Reset	Serial input A	Shift clock	Latch clock	Output enable	SR	LR	SQH	QA to QH
Reset shift register	L	X	X	L,H, ↓	L	L	NC	L	NC
Shift data into shift register	H	D	↑	L,H, ↓	L	D → SR _A SR _N → SR _{N+1}	NC	SR _G → SR _H	NC
Shift register remains unchanged	H	X	L,H, ↓	L,H, ↓	L	NC	NC	NC	NC
Transfer shift register contents to latch register	H	X	L,H, ↓	↑	L	NC	SR _N → LR _N	NC	SR _N
Latch register remains unchanged	X	X	X	L,H, ↓	L	*	NC	*	NC
Enable parallel outputs	X	X	X	X	L	*	**	*	Enabled
Force outputs into high impedance state	X	X	X	X	H	*	**	*	Z

SR: shift register contents LR: latch register contents NC: unchanged
 D: data(L,H) logic level ↑: low-to-high ↓: high-to-low
 *: depends on Reset and Shift Clock inputs **: depends on Latch Clock inputs

■ LOGIC DIAGRAM

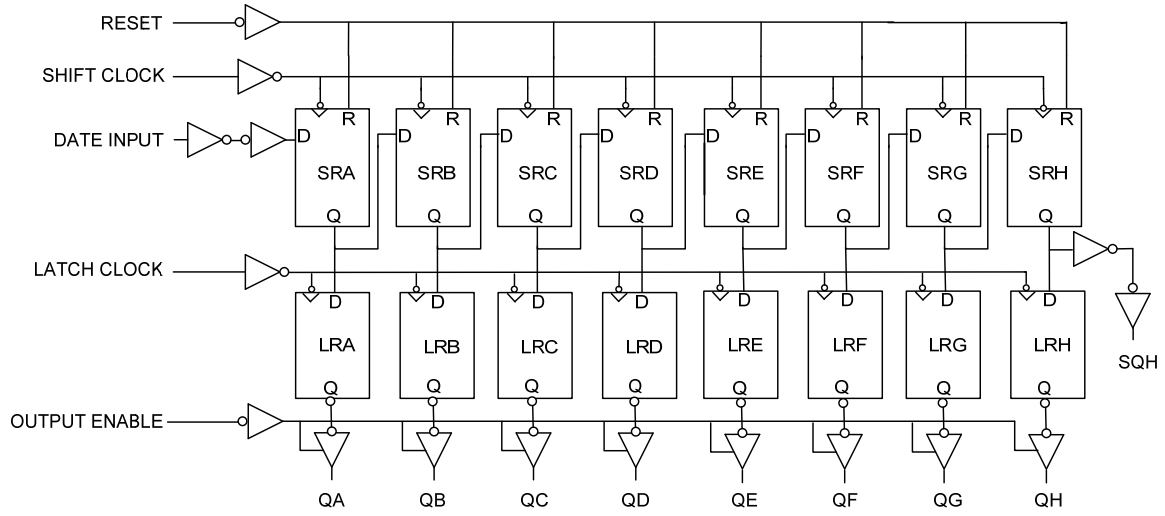

■ ABSOLUTE MAXIMUM RATING (unless otherwise specified)(Note 2)

PARAMETER		SYMBOL	RATINGS	UNIT	
Supply Voltage		V_{CC}	-0.5~7.0	V	
Input Voltage		V_{IN}	-0.5~ $V_{CC}+0.5$	V	
Output Voltage(active mode)		V_{OUT}	-0.5~ $V_{CC}+0.5$	V	
Input Clamp Current ($V_{IN} < 0$)		I_{IK}	± 20	mA	
Output Clamp Current ($V_{OUT} < 0$)		I_{OK}	± 20	mA	
Output Current		I_{OUT}	± 35	mA	
V_{CC} or GND Current		I_{CC}	± 75	mA	
Power Dissipation	SOP-16	P_D	500	mW	
	TSSOP-16		450		
Derate above 65°C~125°C	SOP-16		7	mW	
	TSSOP-16		6.1		
Storage Temperature			T_{STG}	-65 ~ +150	°C

Notes: 1. Absolute maximum ratings are those values beyond which the device could be permanently damaged.

Absolute maximum ratings are stress ratings only and functional device operation is not implied.

2. The input and output voltage ratings may be exceeded if the input and output current ratings are observed.

■ RECOMMENDED OPERATING COMDITIONS

PARAMETER		SYMBOL	MIN	TYP	MAX	UNIT
Supply Voltage		V_{CC}	2		6	V
Input Voltage		V_{IN}	0		V_{CC}	V
Output Voltage		V_{OUT}	0		V_{CC}	V
Operating Temperature		T_{OPR}	-40		125	°C
Input Transition Rise or Fall Rate	$V_{CC} = 2V$	t_R / t_F			1000	ns
	$V_{CC} = 4.5V$				500	ns
	$V_{CC} = 6V$				400	ns

■ ELECTRICAL CHARACTERISTICS

PARAMETER	SYMBOL	TEST CONDITIONS	MIN	TYP	MAX	UNIT
HIGH-level input voltage	V_{IH}	$V_{CC}=2V$	1.5			V
		$V_{CC}=3V$	2.1			V
		$V_{CC}=4.5V$	3.15			V
		$V_{CC}=6V$	4.2			V
LOW-level output voltage	V_{IL}	$V_{CC}=2V$			0.5	V
		$V_{CC}=3V$			0.9	V
		$V_{CC}=4.5V$			1.35	V
		$V_{CC}=6V$			1.8	V
High-Level Output Voltage, QA-QH	V_{OH}	$V_{CC}=2V, I_{OH}=-20\mu A$	1.9			V
		$V_{CC}=4.5V, I_{OH}=-20\mu A$	4.4			V
		$V_{CC}=6V, I_{OH}=-20\mu A$	5.9			V
		$V_{CC}=3V, I_{OH}=-2.4mA$	2.48			V
		$V_{CC}=4.5V, I_{OH}=-6mA$	3.98			V
		$V_{CC}=6V, I_{OH}=-7.8mA$	5.48			V
Low-Level Output Voltage, QA-QH	V_{OL}	$V_{CC}=2V, I_{OL}=20\mu A$			0.1	V
		$V_{CC}=4.5V, I_{OL}=20\mu A$			0.1	V
		$V_{CC}=6V, I_{OL}=20\mu A$			0.1	V
		$V_{CC}=3V, I_{OL}=2.4mA$			0.26	V
		$V_{CC}=4.5V, I_{OL}=6mA$			0.26	V
		$V_{CC}=6V, I_{OL}=7.8mA$			0.26	V
High-Level Output Voltage, SQH	V_{OH}	$V_{CC}=2V, I_{OH}=-20\mu A$	1.9			V
		$V_{CC}=4.5V, I_{OH}=-20\mu A$	4.4			V
		$V_{CC}=6V, I_{OH}=-20\mu A$	5.9			V
		$V_{CC}=3V, I_{OH}=-2.4mA$	2.48			V
		$V_{CC}=4.5V, I_{OH}=-4mA$	3.98			V
		$V_{CC}=6V, I_{OH}=-5.2mA$	5.48			V
Low-Level Output Voltage, SQH	V_{OL}	$V_{CC}=2V, I_{OL}=20\mu A$			0.1	V
		$V_{CC}=4.5V, I_{OL}=20\mu A$			0.1	V
		$V_{CC}=6V, I_{OL}=20\mu A$			0.1	V
		$V_{CC}=3V, I_{OL}=2.4mA$			0.26	V
		$V_{CC}=4.5V, I_{OL}=4mA$			0.26	V
		$V_{CC}=6V, I_{OL}=5.2mA$			0.26	V
Input Leakage Current	$I_{I(LEAK)}$	$V_{CC}=6V, V_{IN}=V_{CC}$ or GND			± 0.1	μA
Output OFF -state current	I_{OZ}	$V_{CC}=6V, V_{OUT}=V_{CC}$ or GND			± 0.5	μA
Quiescent Supply Current	I_Q	$V_{CC}=6V, V_{IN}=V_{CC}$ or GND, $I_{OUT}=0$			4	μA
Input Capacitance	C_{IN}	$V_{CC}=6V, V_{IN}=V_{CC}$ or GND			10	pF

■ DYNAMIC CHARACTERISTICS

PARAMETER	SYMBOL	TEST CONDITIONS	MIN	TYP	MAX	UNIT
Maximum clock pulse frequency	f_{max}	$V_{CC}=2V$			6	MHz
		$V_{CC}=3V$			15	MHz
		$V_{CC}=4.5V$			30	MHz
		$V_{CC}=6V$			35	MHz
Propagation delay from input (Latch Clock) to output(Qn)	t_{PHL}/t_{PLH}	$V_{CC}=2V$			140	ns
		$V_{CC}=3V$			100	ns
		$V_{CC}=4.5V$			28	ns
		$V_{CC}=6V$			24	ns
Propagation delay from input (Output Enable) to output(Qn)	t_{PZL}/t_{PZH}	$V_{CC}=2V$			135	ns
		$V_{CC}=3V$			90	ns
		$V_{CC}=4.5V$			27	ns
		$V_{CC}=6V$			23	ns
Propagation delay from input (Output Enable) to output(Qn)	t_{PLZ}/t_{PHZ}	$V_{CC}=2V$			150	ns
		$V_{CC}=3V$			100	ns
		$V_{CC}=4.5V$			30	ns
		$V_{CC}=6V$			26	ns
Output transition time, SQH	t_{TLH}/t_{THL}	$V_{CC}=2V$			75	ns
		$V_{CC}=3V$			27	ns
		$V_{CC}=4.5V$			15	ns
		$V_{CC}=6V$			13	ns
Propagation delay from input (Reset) to output(SQH)	t_{PHL}	$V_{CC}=2V$			145	ns
		$V_{CC}=3V$			100	ns
		$V_{CC}=4.5V$			29	ns
		$V_{CC}=6V$			25	ns
Propagation delay from input (Shift Clock) to output(SQH)	t_{PLH}/t_{PHL}	$V_{CC}=2V$			140	ns
		$V_{CC}=3V$			100	ns
		$V_{CC}=4.5V$			28	ns
		$V_{CC}=6V$			24	ns
Output transition time, Qn	t_{TLH}/t_{THL}	$V_{CC}=2V$			60	ns
		$V_{CC}=3V$			23	ns
		$V_{CC}=4.5V$			12	ns
		$V_{CC}=6V$			10	ns

■ OPERATING CHARACTERISTICS

PARAMETER	SYMBOL	TEST CONDITIONS	MIN	TYP	MAX	UNIT
Power Dissipation Capacitance	Cpd	No load		300		pF

■ TIMING DIAGRAM

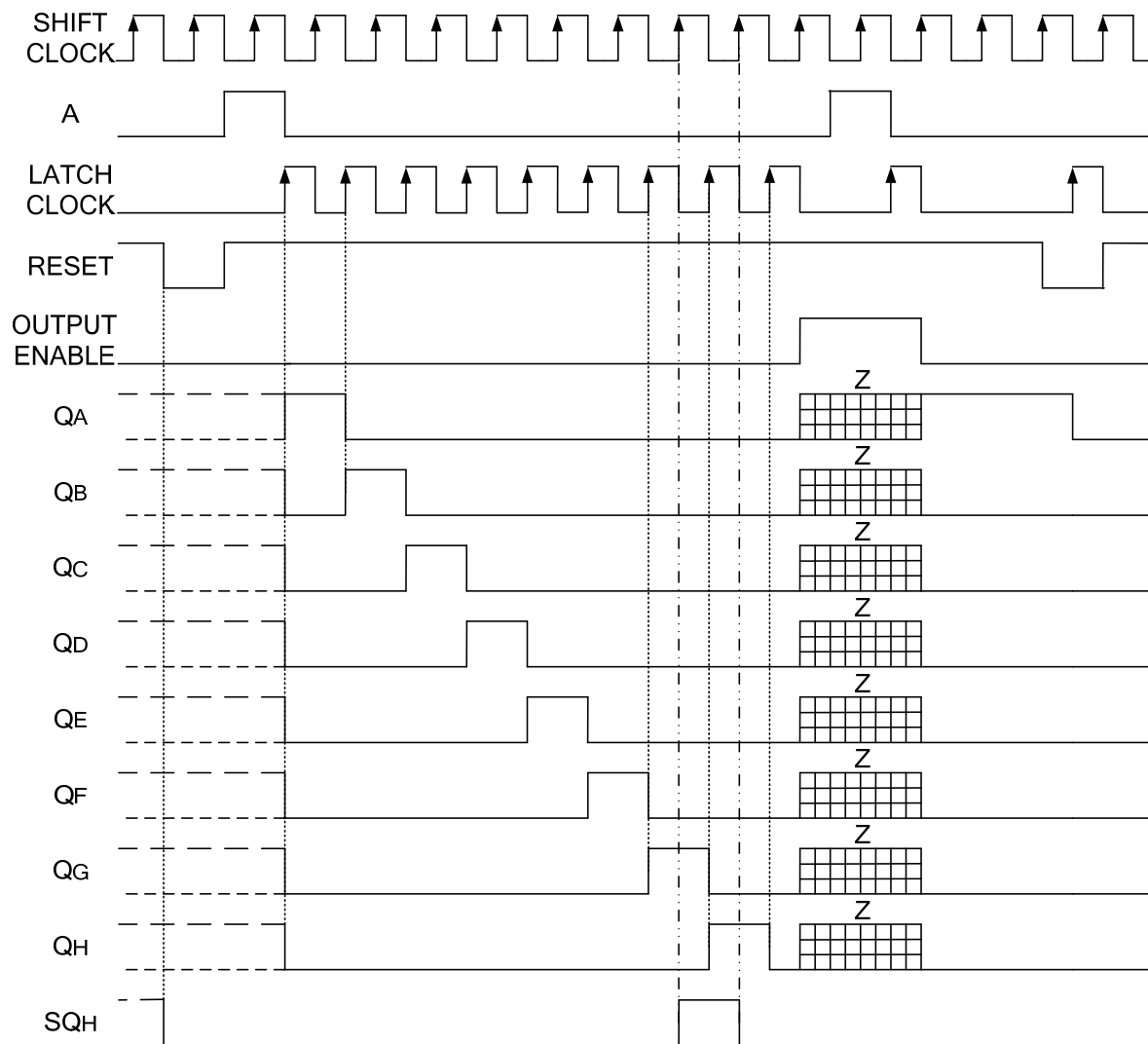

TEST CIRCUIT AND WAVEFORMS

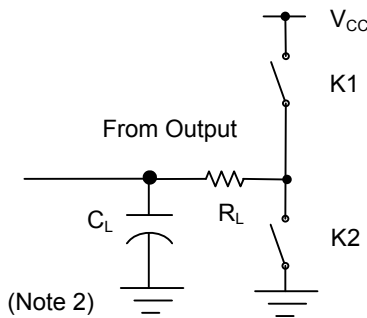

TEST	K1	K2
t_{PLH}/t_{PHL}	Open	Open
t_{PHZ}/t_{PZH}	Close	Open
t_{PLZ}/t_{PZL}	Open	Close

Note 2: CL includes probe and jig capacitance. $C_L=50pF$, $R_L=1K\Omega$

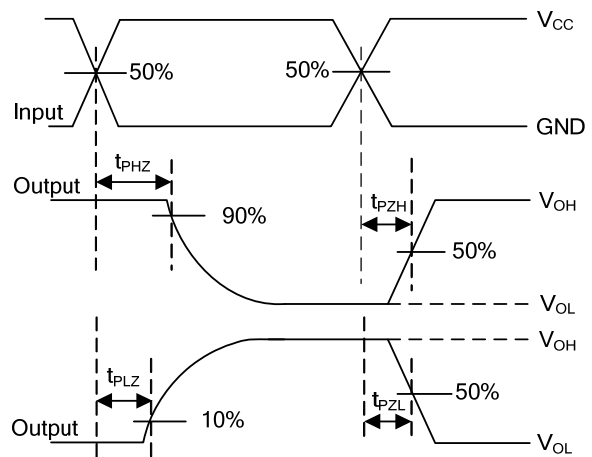
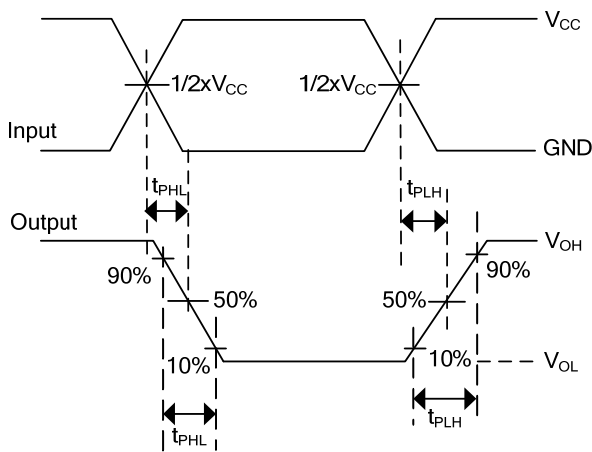

UTC assumes no responsibility for equipment failures that result from using products at values that exceed, even momentarily, rated values (such as maximum ratings, operating condition ranges, or other parameters) listed in products specifications of any and all UTC products described or contained herein. UTC products are not designed for use in life support appliances, devices or systems where malfunction of these products can be reasonably expected to result in personal injury. Reproduction in whole or in part is prohibited without the prior written consent of the copyright owner. The information presented in this document does not form part of any quotation or contract, is believed to be accurate and reliable and may be changed without notice.