



# UM605A/B

## LINEAR INTEGRATED CIRCUIT

### OPERATIONAL AMPLIFIERS WITH 2.5V/1.25V SHUNT REGULATOR

■ DESCRIPTION

UTC **UM605A/B** that is designed to include 2 op amp and one shunt regulator for battery charger and AC adapter application.

■ FEATURES

- \* Small SOT-25 package
- \* Internal accurate 2.5V / 1.25V  $V_{REF}$
- \* Reduced external components

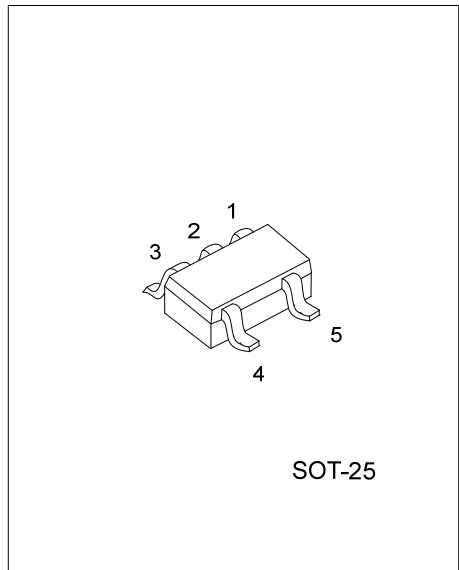

■ ORDERING INFORMATION

Ordering Number		Package	Packing
Lead Free	Halogen Free		
UM605AL-AF5-R	UM605AG-AF5-R	SOT-25	Tape Reel
UM605BL-AF5-R	UM605BG-AF5-R	SOT-25	Tape Reel

<p>UM605AL-AF5-R</p> <p>(1)Packing Type (2)Package Type (3)Lead Free</p>	<p>(1) R: Tape Reel (2) AF5: SOT-25 (3) G: Halogen Free, L: Lead Free</p>
--	---

## MARKING AND PIN DESCRIPTION

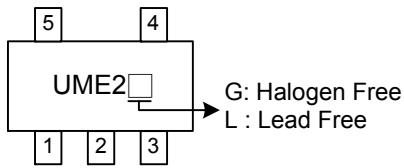

PIN NO.	PIN NAME	FUNCTION	INTERNAL CIRCUIT DIAGRAM
1	OUT	Output Pin	
2	GND	Ground	
3	IN <sub>A</sub>	Input Pin	
4	IN <sub>B</sub>		
5	V <sub>CC</sub>	Supply Voltage	

## BLOCK DIAGRAM

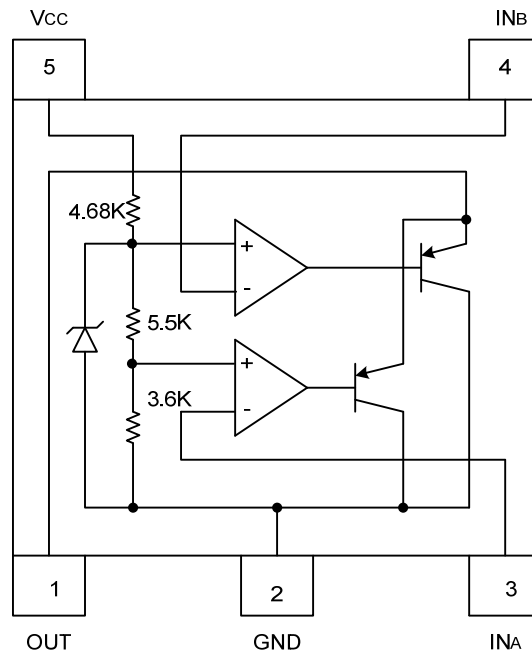

■ ABSOLUTE MAXIMUM RATINGS ( $T_A = 25^\circ\text{C}$ , unless otherwise specified.)

PARAMETER	SYMBOL	RATINGS	UNIT
Supply Voltage	$V_{CC}$	-0.3 ~ +20	V
Recommended Operating Voltage	$V_{OPR}$	+4 ~ +20	V
Power Dissipation	$P_D$	250	mW
Operating Temperature	$T_{OPR}$	-25 ~ +85	$^\circ\text{C}$
Storage Temperature	$T_{STG}$	-40 ~ +125	$^\circ\text{C}$

Note: Absolute maximum ratings are those values beyond which the device could be permanently damaged. Absolute maximum ratings are stress ratings only and functional device operation is not implied.

■ ELECTRICAL CHARACTERISTICS ( $V_{CC}=5\text{V}$ ,  $T_A=25^\circ\text{C}$ , unless otherwise specified.)

**FOR UM605A**

PARAMETER	SYMBOL	TEST CONDITIONS	MIN	TYP	MAX	UNIT
Current Consumption	$I_{CC}$	$IN_A=0\text{V}$ , $IN_B=0\text{V}$ , $R_L=\infty$		2.4	3.4	mA
<b>A AMPLIFIER</b>						
Output Inverting Voltage	$V_A$	$IN_A=0\text{V}$ , $R_L=4.3\text{k}$	2.45	2.50	2.55	V
Output Sink Current	$I_{O(SINK A)}$	$IN_B=2.7\text{V}$ , $IN_A=0\text{V}$ , $V_{OUT}=1.5\text{V}$	5			mA
Input Bias Current	$I_{I(BIAS A)}$	$IN_A=0\text{V}$ , $R_L=4.3\text{k}$		50	140	nA
PSRR	PSRR(A)	$IN_A=0\text{V}$ , $R_L=4.3\text{k}$	50			dB
<b>B AMPLIFIER</b>						
Output Inverting Voltage	$V_B$	$IN_B=0\text{V}$ , $R_L=4.3\text{k}$	152		160	mV
Output Sink Current	$I_{O(SINK B)}$	$IN_B=0\text{V}$ , $IN_A=0.17\text{V}$ , $V_{OUT}=1.5\text{V}$	5			mA
Input Bias Current	$I_{I(BIAS B)}$	$IN_B=0\text{V}$ , $R_L=4.3\text{k}$		50	140	nA
PSRR	PSRR(B)	$IN_B=0\text{V}$ , $R_L=4.3\text{k}$	65			dB

**FOR UM605B**

PARAMETER	SYMBOL	TEST CONDITIONS	MIN	TYP	MAX	UNIT
Current Consumption	$I_{CC}$	$IN_A=0\text{V}$ , $IN_B=0\text{V}$ , $R_L=\infty$		1.2	1.7	mA
<b>A AMPLIFIER</b>						
Output Inverting Voltage	$V_A$	$IN_A=0\text{V}$ , $R_L=4.3\text{k}$	1.225	1.25	1.275	V
Output Sink Current	$I_{O(SINK A)}$	$IN_B=2.7\text{V}$ , $IN_A=0\text{V}$ , $V_{OUT}=1.5\text{V}$	5			mA
Input Bias Current	$I_{I(BIAS A)}$	$IN_A=0\text{V}$ , $R_L=4.3\text{k}$		50	140	nA
PSRR	PSRR(A)	$IN_A=0\text{V}$ , $R_L=4.3\text{k}$	62			dB
<b>B AMPLIFIER</b>						
Output Inverting Voltage	$V_B$	$IN_B=0\text{V}$ , $R_L=4.3\text{k}$	152		160	mV
Output Sink Current	$I_{O(SINK B)}$	$IN_B=0\text{V}$ , $IN_A=0.17\text{V}$ , $V_{OUT}=1.5\text{V}$	5			mA
Input Bias Current	$I_{I(BIAS B)}$	$IN_B=0\text{V}$ , $R_L=4.3\text{k}$		50	140	nA
PSRR	PSRR(B)	$IN_B=0\text{V}$ , $R_L=4.3\text{k}$	65			dB

