



LM317L

LINEAR INTEGRATED CIRCUIT

LOW CURRENT 1.25V TO 37V ADJUSTABLE VOLTAGE REGULATOR

DESCRIPTION

The UTC **LM317L** is a monolithic integrated circuit, designed to supply 100mA of output current with voltage adjustable from 1.25V ~ 37V.

FEATURES

- *Output voltage adjustable from 1.25V ~ 37V.
- *Output current in excess of 100mA
- *Internal thermal overload protection
- *Internal short circuit current limiting
- *Output transistor safe area compensation

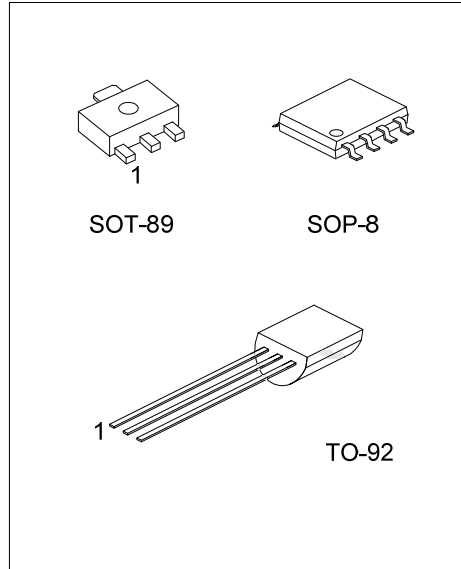

ORDERING INFORMATION

Ordering Number		Package	Pin Assignment								Packing
Lead Free	Halogen Free		1	2	3	4	5	6	7	8	
LM317LK-AB3-R	LM317LG-AB3-R	SOT-89	A	O	I	-	-	-	-	-	Tape Reel
LM317LK-T92-B	LM317LG-T92-B	TO-92	A	O	I	-	-	-	-	-	Tape Box
LM317LK-T92-K	LM317LG-T92-K	TO-92	A	O	I	-	-	-	-	-	Bulk
LM317LK-S08-R	LM317LG-S08-R	SOP-8	I	O	O	A	N	O	O	N	Tape Reel
LM317LK-S08-T	LM317LG-S08-T	SOP-8	I	O	O	A	N	O	O	N	Tube

Note: Pin Assignment: A: ADJ I: V_{IN} O: V_{OUT} N: No Connection

<p>LM317LG-AB3-R</p> <p>(1)Packing Type (2)Package Type (3)Green Package</p>	<p>(1) R: Tape Reel, B: Tape Box, K: Bulk, T: Tube (2) AB3: SOT-89, T92: TO-92, S08: SOP-8 (3) G: Halogen Free and Lead Free, K: Lead Free</p>
--	--

MARKING

SOT-89	SOP-8	TO-92
<p>□□□□ → Date Code LM317L□ → K: Lead Free G: Halogen Free 1</p>	<p>8 7 6 5 → Date Code UTC □□□□ → K: Lead Free LM317L□ → G: Halogen Free □□□ → Lot Code 1 2 3 4</p>	<p>UTC LM317L□ → K: Lead Free □□□ → G: Halogen Free □□□ → Date Code 1</p>

■ BLOCK DIAGRAM

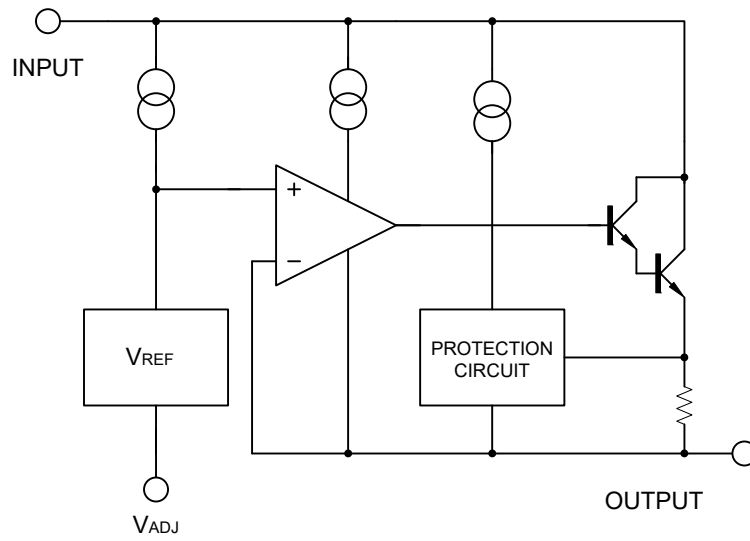

■ ABSOLUTE MAXIMUM RATINGS

PARAMETER	SYMBOL	RATING	UNIT
Input-Output Differential Voltage	$V_{IN}-V_{OUT}$	40	V
Power Dissipation	P_D	Internally Limited	
Operating Junction Temperature	T_{OPR}	-40 ~ +150	°C
Storage Temperature Range	T_{STR}	-40 ~ +150	°C

Note: Absolute maximum ratings are those values beyond which the device could be permanently damaged. Absolute maximum ratings are stress ratings only and functional device operation is not implied.

■ THERMAL CHARACTERISTICS

PARAMETER	SYMBOL	RATINGS	UNIT
Junction to Ambient	SOT-89	180	°C/W
	SOP-8	175	°C/W
	TO-92	190	°C/W
Junction to Case	SOT-89	50	°C/W
	SOP-8	27	°C/W
	TO-92	83	°C/W

■ ELECTRICAL CHARACTERISTICS

($V_{IN}-V_{OUT}=5V$, $I_{OUT}=40mA$, $T_a=25^{\circ}C$, unless otherwise specified.)

PARAMETER	SYMBOL	TEST CONDITIONS	MIN	TYP	MAX	UNIT	
Line Regulation	$\Delta V_{OUT}/V_{OUT}$	$3V \leq V_{IN}-V_{OUT} \leq 40V$, $I_{LOAD} < 20mA$		0.01	0.04	%/V	
Load Regulation	ΔV_{OUT}	$5mA \leq I_{OUT} \leq 100mA$	$V_{OUT} \leq 5V$	5	25	mV	
			$V_{OUT} \geq 5V$	0.1	0.5	%	
Adjustable Pin Current	I_{ADJ}			50	100	μA	
Adjustable Pin Current Change	ΔI_{ADJ}	$3V \leq V_{IN}-V_{OUT} \leq 40V$, $5mA \leq I_{OUT} \leq 100mA$, $P_D < 625mW$		0.2	5	μA	
Reference Voltage	V_{REF}	$3V \leq V_{IN}-V_{OUT} \leq 40V$, $5mA \leq I_{OUT} \leq 100mA$, $P_D < 625mW$	1.20	1.25	1.30	V	
Temperature Stability		$T_{MIN} \leq T_J \leq T_{MAX}$		0.7		%/V _{OUT}	
Minimum Load Current for Regulation	$I_{L(MIN)}$	$V_{IN}-V_{OUT}=40V$		3.5	10	mA	
Maximum Output Current	$I_{O(MAX)}$	$V_{IN}-V_{OUT} \leq 40V$, $P_D < 625mW$		15		mA	
RMS Noise vs. % of V_{OUT}	eN	$10Hz \leq f \leq 10KHz$		0.003	0.01	%/V _{OUT}	
Ripple Rejection	RR	$V_{OUT}=10V, f=120Hz$,	$C_{ADJ}=0$		65		dB
			$C_{ADJ}=10\mu F$	66	80		dB

Note: C_{ADJ} is connected between Adjust pin and Ground.

APPLICATION CIRCUITS

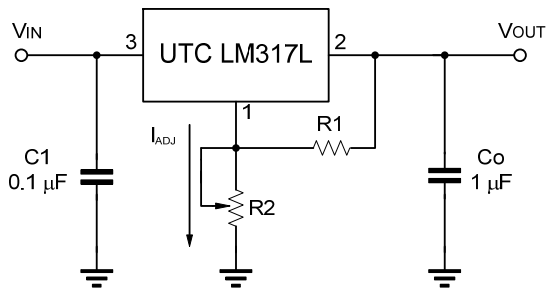

Fig.1 Programmable voltage regulator

$$V_{OUT} = 1.25V * (1 + R2/R1) + I_{ADJ} * R2$$

C1 is required when regulator is located an appreciated distance from power supply. Co is needed to improve transient response.

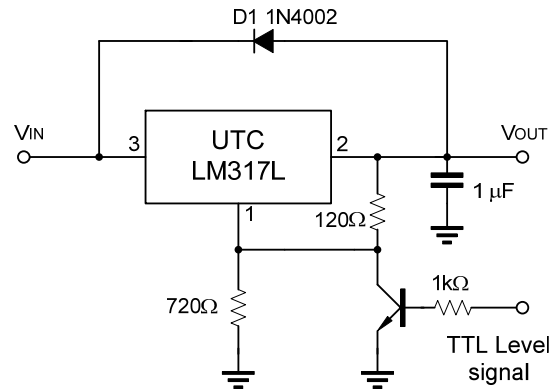

Fig.2 Regulator with On-off control

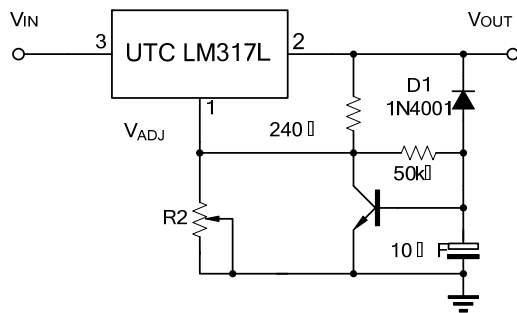
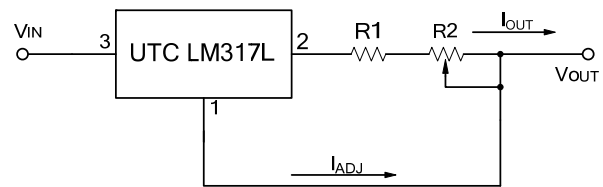

Fig.3 Soft Start Application



$$I_{O(MAX)} = \left(\frac{V_{REF}}{R1} \right) + I_{ADJ} = \frac{1.25V}{R1}$$

$$I_{O(MIN)} = \left(\frac{V_{REF}}{R1 + R2} \right) + I_{ADJ} = \frac{1.25V}{R1 + R2}$$

Fig.4 Constant Current Application

■ TYPICAL CHARACTERISTICS

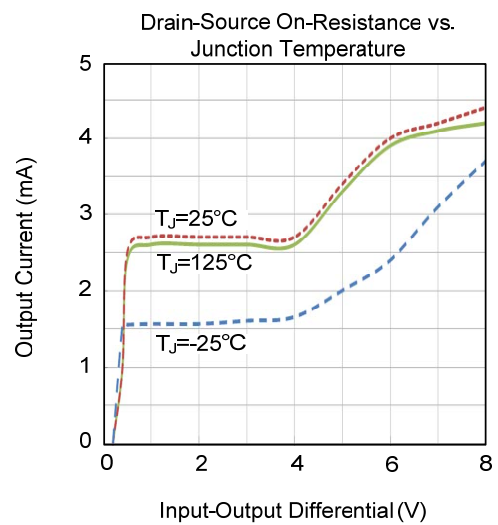
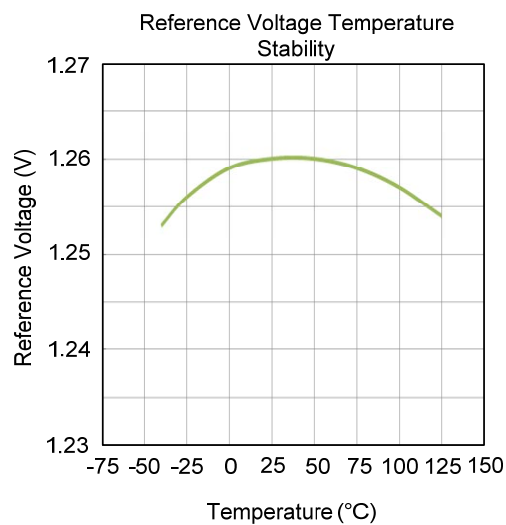
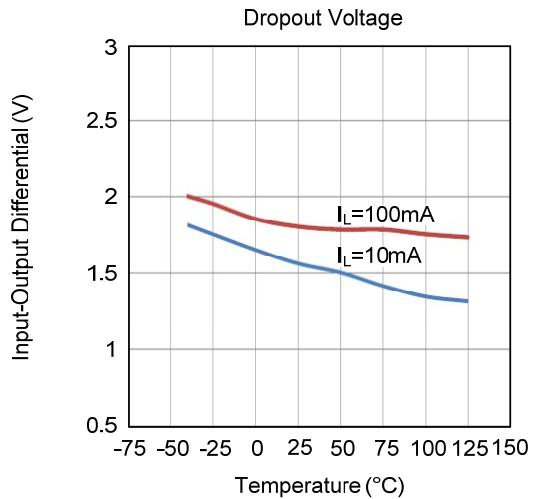
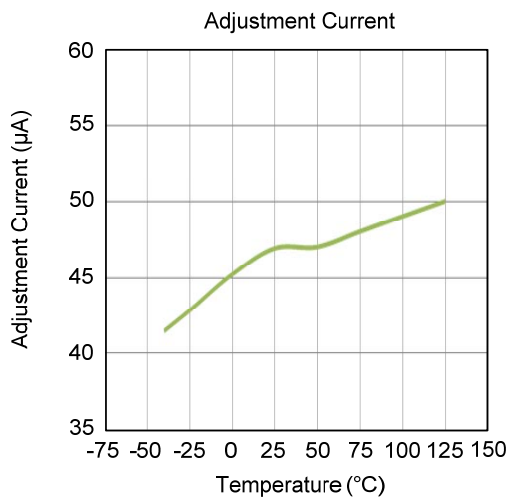
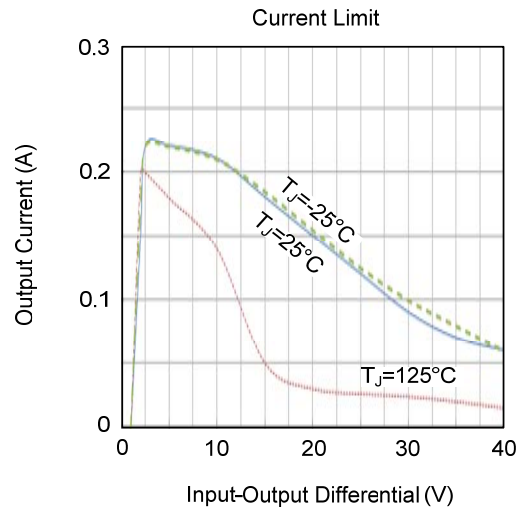
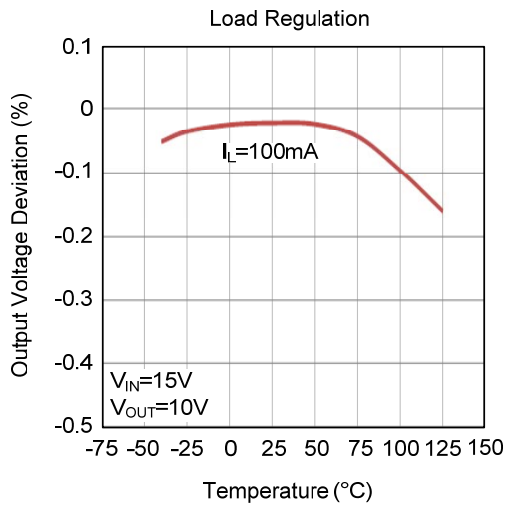

UTC assumes no responsibility for equipment failures that result from using products at values that exceed, even momentarily, rated values (such as maximum ratings, operating condition ranges, or other parameters) listed in products specifications of any and all UTC products described or contained herein. UTC products are not designed for use in life support appliances, devices or systems where malfunction of these products can be reasonably expected to result in personal injury. Reproduction in whole or in part is prohibited without the prior written consent of the copyright owner. UTC reserves the right to make changes to information published in this document, including without limitation specifications and product descriptions, at any time and without notice. This document supersedes and replaces all information supplied prior to the publication hereof.