



UC5301

CMOS IC

SWITCHED-CAPACITOR VOLTAGE INVERTERS

DESCRIPTION

The UTC **UC5301** is an unregulated charge-pump voltage inverter. It can be used to generate a negative supply from positive input. Input voltages varying from +1.8V to +5V can be inverted into a -1.8V ~ -5V output supply.

The device can be operated on a 0.45mA typical current from supplies 3.3V, which meets the requirements of battery-powered and board level voltage conversion applications.

The UTC **UC5301** can deliver 25mA output current with a voltage drop of 250mV. The parts are over-temperature protected.

The UTC **UC5301** is generally used in cell phones, PDAs, and other portable equipments, small LCD panels, handy-terminals.

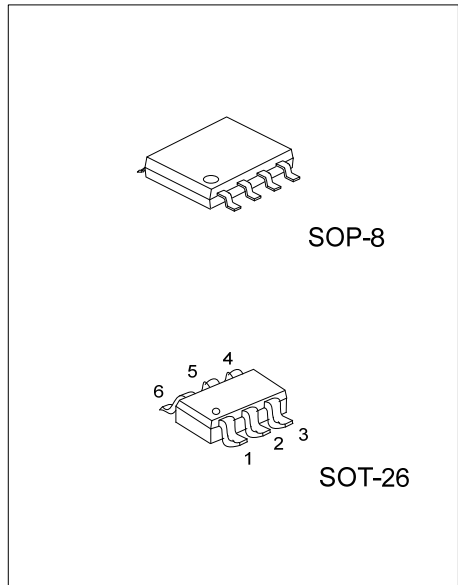

FEATURES

- * Operating voltage range: 1.8V ~ 5V
- * Inverts input supply voltage
- * 25mA output current with a voltage drop of 250mV
- * Quiescent current 0.45mA from supplis 3.3V
- * Voltage conversion efficiency up to 99%
- * Only two capacitors needed
- * Over-temperature circuit
- * 2KV ESD rating

ORDERING INFORMATION

Ordering Number		Package	Packing
Lead Free	Halogen Free		
UC5301L-AL6-R	UC5301G-AG6-R	SOT-26	Tape Reel
UC5301L-S08-R	UC5301G-S08-R	SOP-8	Tape Reel

<p>UC5301G-AG6-R</p> <p>(1) Packing Type (2) Package Type (3) Green Package</p>	<p>(1) R: Tape Reel (2) AG6: SOT-26, S08: SOP-8 (3) G: Halogen Free and Lead Free, L: Lead Free</p>
---	---

MARKING

SOT-26	SOP-8
	<p>Date Code L: Lead Free G: Halogen Free Lot Code</p>

■ PIN CONFIGURATION

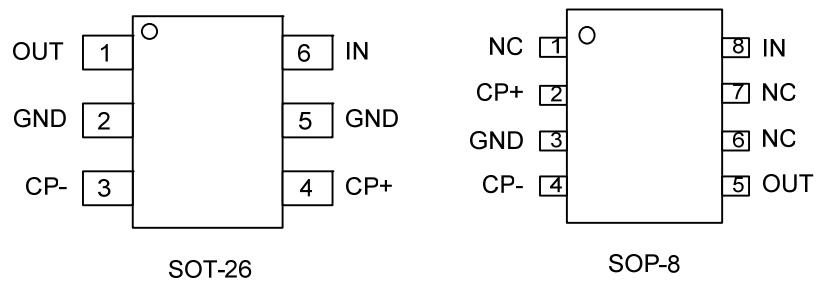

■ PIN DESCRIPTION

PIN NO.		PIN NAME	DESCRIPTION
SOT-26	SOP-8		
1	5	OUT	Inverting Charge-Pump Output
2, 5	3	GND	Ground
3	4	CP-	Flying Capacitor's Negative Terminal
4	2	CP+	Flying Capacitor's Positive Terminal
6	8	IN	Power-Supply Positive Voltage Input
-	1,6,7	NC	Not Internally Connected

■ BLOCK DIAGRAM

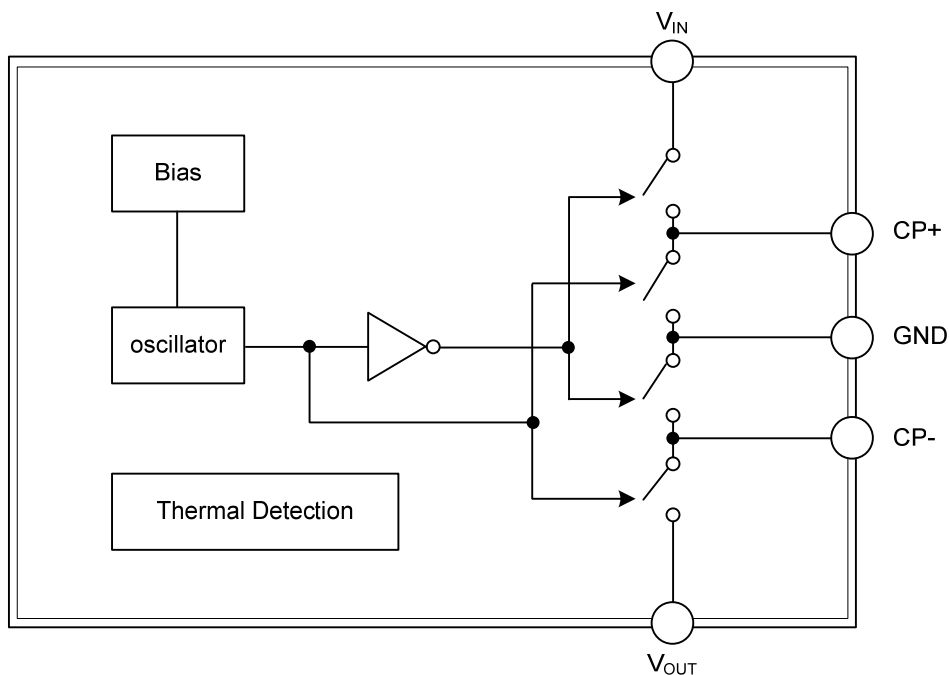

■ ABSOLUTE MAXIMUM RATING ($T_A=25^\circ\text{C}$ unless otherwise specified.)

PARAMETER	SYMBOL	RATINGS	UNIT
IN to GND Voltage	V_{IN}	-0.3V ~ +5.5V	V
OUT to GND Voltage	V_{OUT}	-5.5V ~ +0.3V	V
C1+ to GND Voltage	V_{C+}	-0.3V ~ ($V_{IN}+0.3V$)	V
C1- to GND Voltage	V_{C-}	($V_{OUT}-0.3V$) ~ +0.3V	V
OUT Output Current	I_{OUT}	100mA	mA
OUT Short Circuit to GND		Indefinite	
Junction Temperature	T_J	+150	$^\circ\text{C}$
Storage Temperature	T_S	-65 ~ +150	$^\circ\text{C}$
Operating Temperature	T_{OPR}	-40 ~ +85	$^\circ\text{C}$

Notes: 1. Absolute maximum ratings are those values beyond which the device could be permanently damaged.

Absolute maximum ratings are stress ratings only and functional operation is not implied.

2. Human body model is a 100pF capacitor discharged through a 1.5k Ω resistor into each pin.

■ THERMAL DATA

PARAMETER	SYMBOL	RATINGS	UNIT
Junction to Ambient	SOT-26	280	$^\circ\text{C}/\text{W}$
	SOP-8	160	$^\circ\text{C}/\text{W}$

■ ELECTRICAL CHARACTERISTICS

($V_{IN}=+3.3V/5.0V$, $C1 = C2 = C3= 1\mu\text{F}$, $T_A= -40 \sim +85^\circ\text{C}$ unless otherwise specified. Typical values is at $T_A=25^\circ\text{C}$.)

PARAMETER	SYMBOL	TEST CONDITIONS	MIN	TYP	MAX	UNIT
Input Voltage	V_{IN}	$R_{LOAD}=10k\Omega$	1.8		5	V
Supply Current	I_Q	$V_{IN}=+3.3V$, $T_A=25^\circ\text{C}$		0.42	0.5	mA
		$V_{IN}=+5.0V$, $T_A=25^\circ\text{C}$		0.9		
Charge Pump Frequency	F_{SW}	$V_{IN}=3.3V$	200	250	300	kHz
		$V_{IN}=5.0V$		260		
Output Resistance (Note)	R_{OUT}	$V_{IN}=3.3V$, $I_{LOAD}=5mA$		9		Ω
		$V_{IN}=5.0V$, $I_{LOAD}=5mA$		9.5		
Output Ripple	V_{RIPPLE}	$V_{IN}=3.3V$, $I_{LOAD}=5mA$		13		mV _{P-P}
		$V_{IN}=3.3V$, $I_{LOAD}=25mA$		55		
		$V_{IN}=5.0V$, $I_{LOAD}=5mA$		23		
		$V_{IN}=5.0V$, $I_{LOAD}=25mA$		96		
Voltage Conversion Efficiency		$V_{IN}=3.3V/5.0V$ No Load	99			%
Power Efficiency		$V_{IN}=3.3V$, $I_{LOAD}=5mA$		93		%
		$V_{IN}=5.0V$, $I_{LOAD}=10mA$		90		%

Note: Capacitor contribution ($\text{ESR component plus } (1/F_{SW}) \cdot C$) is approximately 20% of output.

■ DETAILED DESCRIPTION

Four switches (S1, S2, S3, and S4) incorporated in the device, which are switched in a sequence to invert the input supply voltage. The external capacitors determine the energy transfer and storage.

The course of voltage conversion is show in Figure. 1. When S1 and S3 are closed, C1 charges to the supply voltage V_{IN} . During this time interval, switches S2 and S4 are open. In the second time interval, S1 and S3 are open; at the same time, S2 and S4 are closed, C1 is charging C2. After a number of cycles, the voltage across C2 will be pumped to V_{IN} . Since the anode of C2 is connected to ground, the output at the cathode of C2 equals $-(V_{IN})$ under o load current condition.

The UTC **UC5301** is mainly to generate a negative supply voltage. The input supply voltage is varying from 1.8V to 5V. The output characteristics of this circuit can be approximated by an ideal voltage source in series with a resistance. The voltage source equals $-(V_{IN})$.

The output resistance, R_{OUT} , is a function of the ON resistance of the internal MOSFET switches, the oscillator frequency, the capacitance and the ESR of both C1 and C2. Since the switching current charging and discharging C1 is approximately twice as the output current, the effect of the ESR of the pumping capacitor C1 will be multiplied by four in the output resistance. The output capacitor C2 is charging and discharging at a current approximately equal to the output current, therefore, this ESR term only counts once in the output resistance. The value of R_{OUT} is approximately calculated in the following equation:

$$R_{OUT} \cong 2R_{SW} + \frac{2}{f_{OSC} \times C_1} + 4ESR_{C1} + ESR_{C2}$$

(R_{SW} is the sum of the ON resistance of the internal MOSFET switches shown in Figure 1.)

Lower output resistance is dependent on higher capacitance and lower ESR capacitors.

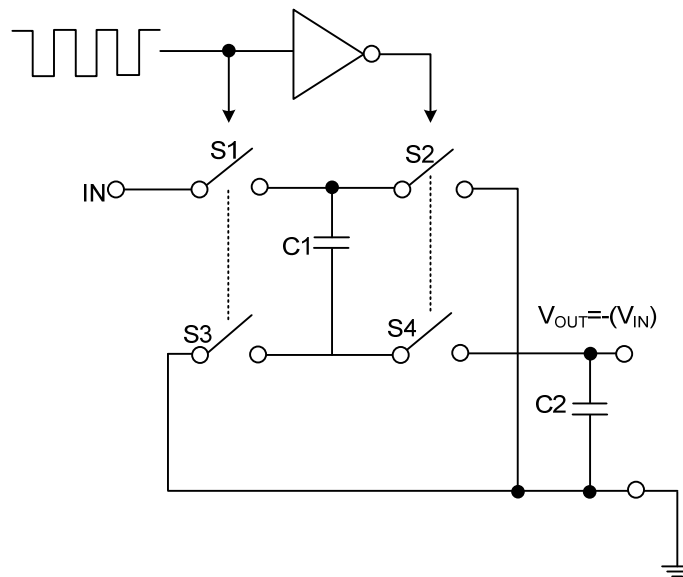

Figure 1. Ideal Voltage Inverter

■ APPLICATION INFORMATION

Table 1. Low-ESR Capacitor Manufacturers

PRODUCTION METHOD	MANUFACTURER	SERIES
Surface-Mount Ceramic	AVX	X7R
	Matsuo	X7R

Capacitor Selection

Proper selection of external capacitor in applications is critical to keep the lowest output resistance; the capacitors should be with low ESR (Table 1). Minimizing the charge-pump capacitor’s ESR minimizes the total output resistance because the charge-pump output resistance is a function of C1’s and C2’s ESR.

Flying Capacitor (C1)

Increasing the flying capacitor’s value reduces the output resistance. Above a certain point, increasing C1’s capacitance has a negligible effect because the output resistance becomes dominated by the internal switch resistance and capacitor ESR.

Output Capacitor (C2)

Increasing the output capacitor’s value reduces the output ripple voltage. Decreasing its ESR reduces both output resistance and ripple. Lower capacitance values can be used with light loads if higher output ripple can be tolerated. The peak-to-peak ripple is determined by the following equations:

$$V_{RIPPLE} = \frac{I_L}{f_{OSC} \times C2} + 2XI_L + ESR_{C2}$$

The output voltage drop is the load current times the output resistance, and the power efficiency is calculated as:

$$\eta = \frac{P_{OUT}}{P_{IN}} = \frac{I_L^2 R_L}{I_L^2 R_L + I_L^2 R_{OUT} + I_Q (V_{IN})}$$

($I_Q(V_{IN})$ is the quiescent power loss of the IC device, and $I_L^2 R_{OUT}$ is the conversion loss associated with the switch on-resistance, the two external capacitors and their ESRs.)

Input Bypass Capacitor (C3)

Input bypass capacitor is used to bypass the incoming supply to reduce its AC impedance and the impact of the UTC **UC5301**’s switching noise. The value of a bypass capacitor is recommended to be equal to the C1.

Voltage Inverter

The device is mainly for application as a charge-pump voltage inverter (Figure 2). Less external capacitors are required. (C1, C2 and a bypass capacitor, if necessary.)

Layout and Grounding

For a better noise performance, a good layout is necessary. Therefore, it’s best to mount all components as close together as possible, keep traces short to minimize parasitic inductance and capacitance and use a ground plane.

■ TYPICAL OPERATING CIRCUIT

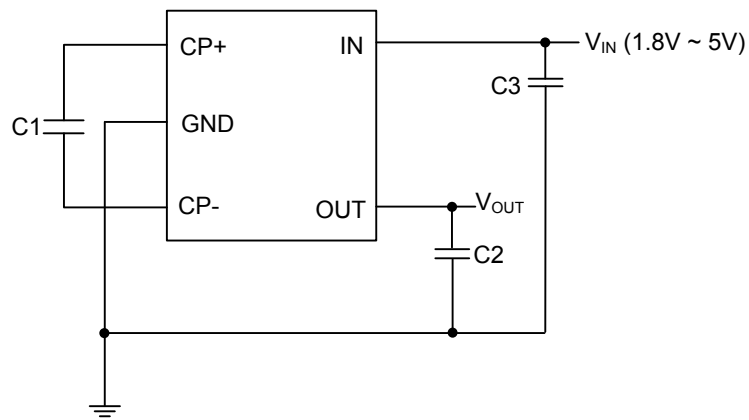

C1,C2,C3: 1 μ F MLCC

■ TYPICAL APPLICATION CIRCUIT

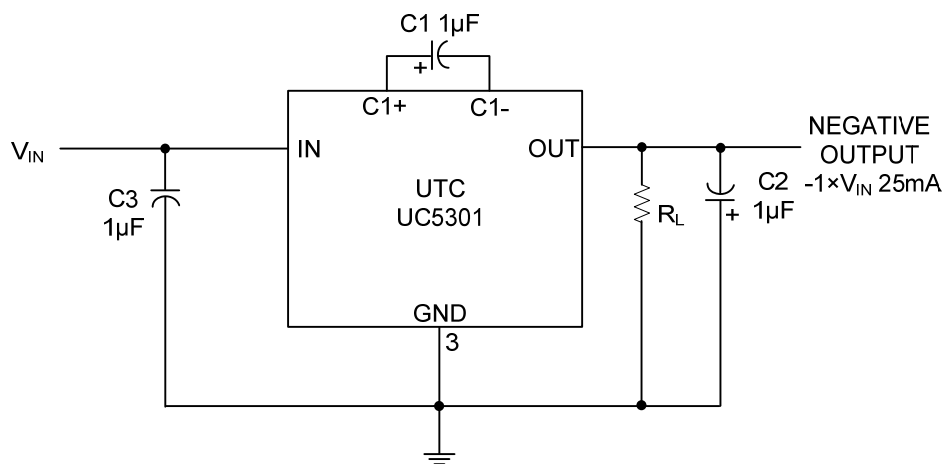
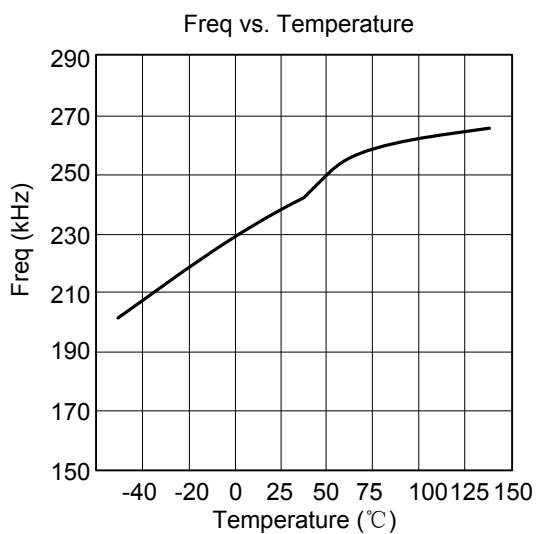
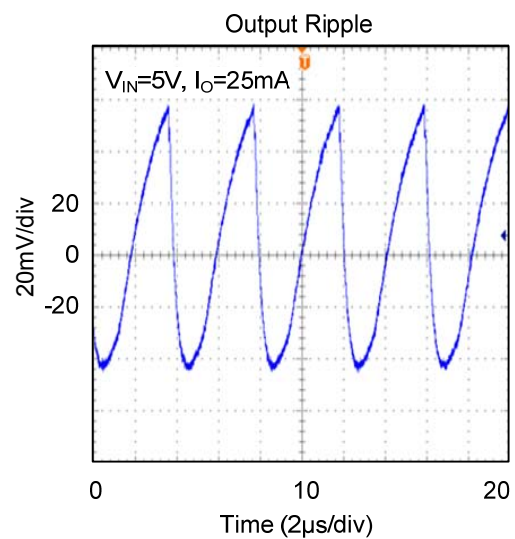
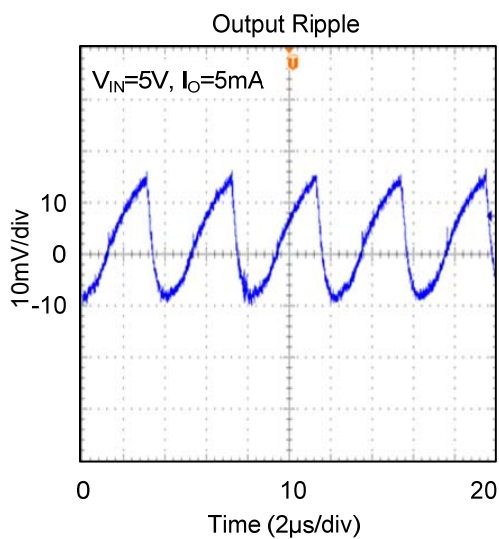
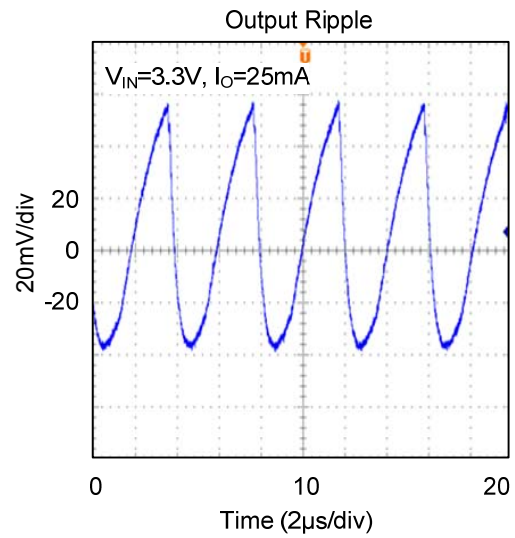
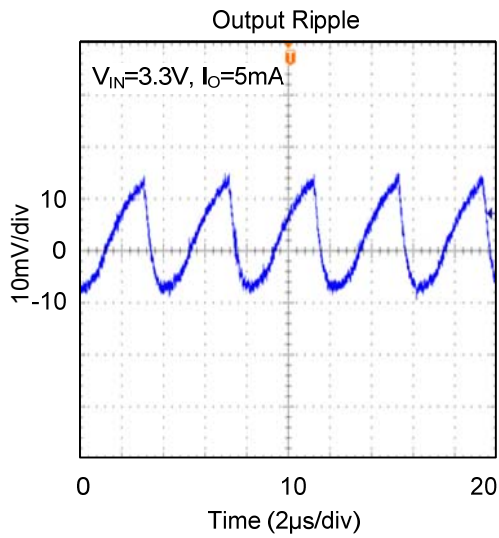

Figure 2. Typical Application Circuit

■ TYPICAL CHARACTERISTICS



UTC assumes no responsibility for equipment failures that result from using products at values that exceed, even momentarily, rated values (such as maximum ratings, operating condition ranges, or other parameters) listed in products specifications of any and all UTC products described or contained herein. UTC products are not designed for use in life support appliances, devices or systems where malfunction of these products can be reasonably expected to result in personal injury. Reproduction in whole or in part is prohibited without the prior written consent of the copyright owner. UTC reserves the right to make changes to information published in this document, including without limitation specifications and product descriptions, at any time and without notice. This document supersedes and replaces all information supplied prior to the publication hereof.