



LM339

LINEAR INTEGRATED CIRCUIT

QUAD DIFFERENTIAL COMPARATOR

DESCRIPTION

The UTC **LM339** consists of four independent voltage comparators, designed specifically to operate from a single power supply over a wide voltage range.

FEATURES

- * Signal or Dual Supply Operation
- * Wide Operating Supply Range ($V_{CC}=2V\sim 36V$)
- * Input Common-Mode Voltage Includes Ground.
- * Low Supply Current $I_{CC}=1.1mA$ (Typical)
- * Open Collector Outputs for Wired and Connection
- * Low Input Bias Current $I_{BIAS}=25nA$ (Typical)
- * Low Output Saturation Voltage
- * Output Compatible with TTL, DTL, and CMOS Logic System

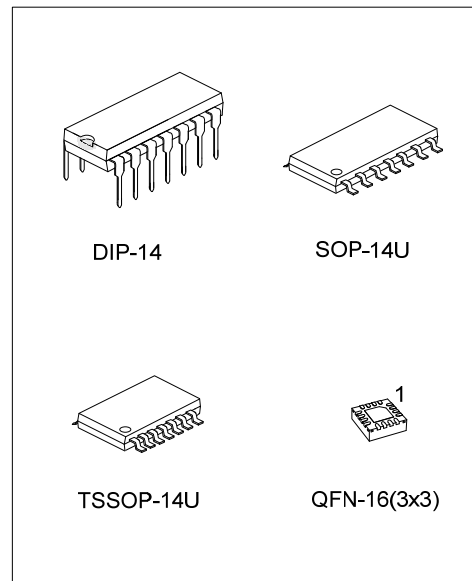

ORDERING INFORMATION

Ordering Number		Package	Packing
Lead Free	Halogen-Free		
LM339L-D14-T	LM339G-D14-T	DIP-14	Tube
LM339L-UEA-R	LM339G-UEA-R	SOP-14U	Tape Reel
LM339L-UEB-R	LM339G-UEB-R	TSSOP-14U	Tape Reel
LM339L-Q16-3030-R	LM339G-Q16-3030-R	QFN-16(3x3)	Tape Reel

<p>LM339G-D14-T</p> <p>(1)Packing Type (2)Package Type (3)Green Package</p>	<p>(1) T: Tube, R: Tape Reel (2) DIP: DIP-14, UEA: SOP-14U, UEB: TSSOP-14U Q16-3030: QFN-16(3x3) (3) G: Halogen Free and Lead Free, L: Lead Free</p>
---	--

MARKING

PACKAGE	MARKING
DIP-14	<p> UTC □□□□ → Date Code L: Lead Free G: Halogen Free □□□□ → Lot Code </p>
SOP-14U TSSOP-14U	<p> UTC □□□□ → Date Code L: Lead Free G: Halogen Free □□□□ → Lot Code </p>
QFN-16(3×3)	<p> L: Lead Free G: Halogen Free □□□□ → Date Code Lot Code ← □□□□ </p>

PIN CONFIGURATION

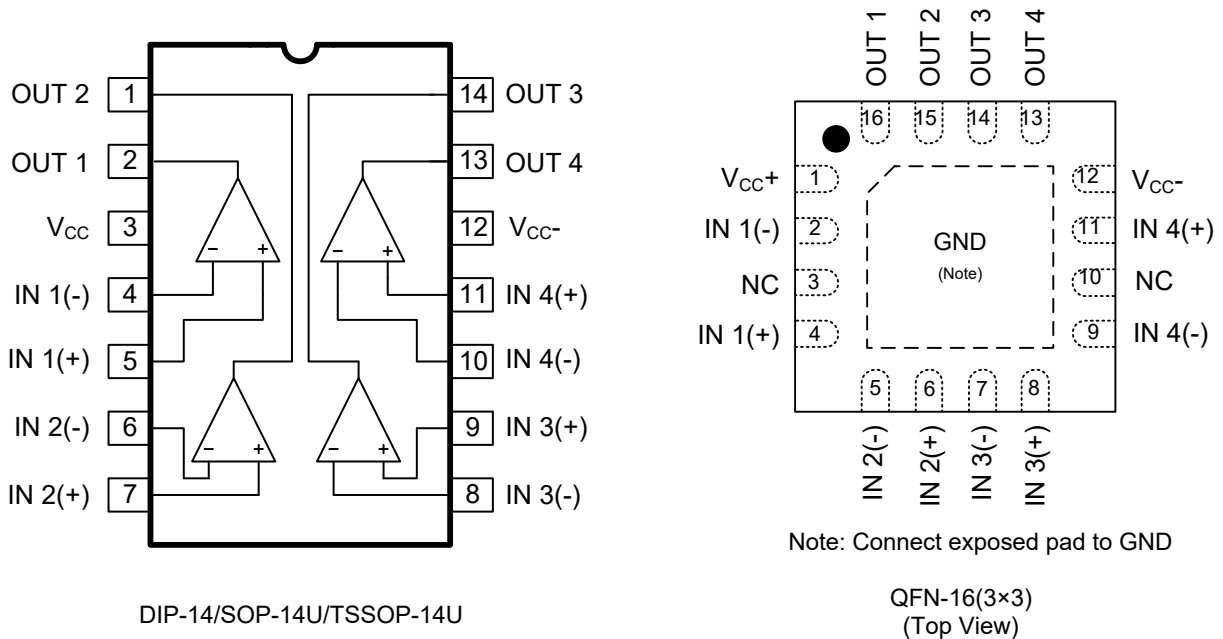

■ ABSOLUTE MAXIMUM RATINGS ($T_A=25^\circ\text{C}$, unless otherwise specified)

PARAMETER		SYMBOL	RATINGS	UNIT
Supply Voltage		V_{CC}	± 18 or 36	V
Differential input Voltage		$V_{I(DIFF)}$	36	V
Input Voltage		V_{IN}	-0.3 ~ 36	V
Power Dissipation	DIP-14	P_D	800	mW
	SOP-14U		480	mW
	TSSOP-14U		360	mW
	QFN-16(3×3)		1300	mW
Junction Temperature		T_J	+150	$^\circ\text{C}$
Operating Temperature		T_{OPR}	-20 ~ +85	$^\circ\text{C}$
Storage Temperature		T_{STG}	-65 ~ +150	$^\circ\text{C}$

Notes: 1. Absolute maximum ratings are those values beyond which the device could be permanently damaged.

Absolute maximum ratings are stress ratings only and functional device operation is not implied.

2. It is guarantee by design, not 100% be tested.

■ ELECTRICAL CHARACTERISTICS

($V_{CC}=5.0\text{V}$, All voltage referenced to GND unless otherwise specified)

PARAMETER	SYMBOL	TEST CONDITIONS	MIN	TYP	MAX	UNIT
Input Offset Voltage	$V_{I(OFF)}$	$V_{CM}=0\sim V_{CC}-1.5$, $V_{OUT(P)}=1.4\text{V}$, $R_S=0$		± 1.5	± 3.0	mV
		$T_A=25^\circ\text{C}$			± 9.0	mV
Input Offset Current	$I_{I(OFF)}$	$T_A=25^\circ\text{C}$		± 2.3	± 50	nA
		$T_A=-20\sim+85^\circ\text{C}$			± 150	nA
Input Bias Current	I_{BIAS}	$T_A=25^\circ\text{C}$		25	250	nA
		$T_A=-20\sim+85^\circ\text{C}$			400	nA
Input Common Mode Voltage	$V_{I(CM)}$	$T_A=25^\circ\text{C}$	0		$V_{CC}-1.5$	V
		$T_A=-20\sim+85^\circ\text{C}$	0		$V_{CC}-2.0$	V
Supply Current	I_{CC}	$R_L=\infty$		1.7	2.0	mA
		$T_A=25^\circ\text{C}$			3.0	mA
Large Signal Voltage Gain	G_V	$T_A=-20\sim+85^\circ\text{C}$				
		$V_{CC}=15\text{V}$, $R_L>15\text{k}\Omega$, $T_A=25^\circ\text{C}$	50	200		V/mV
Large Signal Response Time	t_{RES}	$V_{IN}=\text{TTL logic wing}$ $V_{REF}=1.4\text{V}$, $V_{RL}=5\text{V}$, $R_L=5.1\text{k}\Omega$, $T_A=25^\circ\text{C}$		350		ns
		$V_{RL}=5\text{V}$, $R_L=5.1\text{k}\Omega$, $T_A=25^\circ\text{C}$		1400		ns
Response Time	t_{RES}	$V_{RL}=5\text{V}$, $R_L=5.1\text{k}\Omega$, $T_A=25^\circ\text{C}$		1400		ns
Output Sink Current	I_{SINK}	$V_{IN(-)}>1\text{V}$, $V_{IN(+)}=0\text{V}$, $V_{OUT(P)}<1.5\text{V}$	6	18		mA
Output Saturation Voltage	V_{SAT}	$V_{IN(-)}>1\text{V}$, $V_{IN(+)}=0\text{V}$, $I_{SINK}=4\text{mA}$		140	400	mV
		$T_A=25^\circ\text{C}$			700	mV
Output Leakage Current	I_{LEAK}	$V_{IN(+)}=1\text{V}$, $V_{IN(-)}=0\text{V}$, $T_A=25^\circ\text{C}$		0.1		nA
		$V_{OUT(P)}=5\text{V}$ $V_{OUT(P)}=30\text{V}$			1	μA
Differential Input Voltage	$V_{I(DIFF)}$	$T_A=-20\sim+85^\circ\text{C}$			V_{CC}	V

TYPICAL CHARACTERISTICS

Fig.1 Supply Current

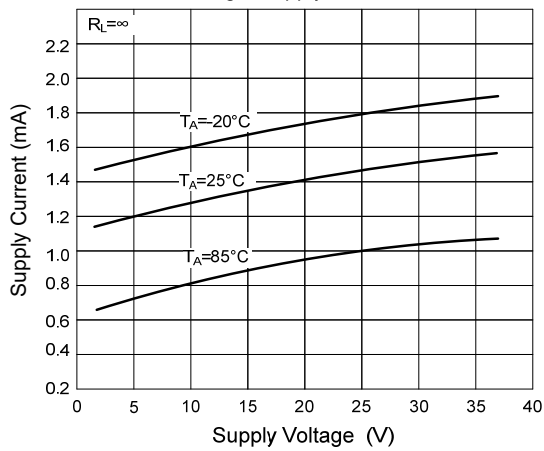

Fig.2 Input Bias Current

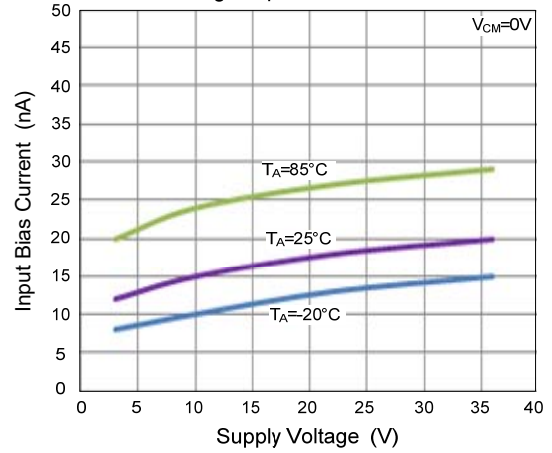

Fig.3 Output Saturation Voltage

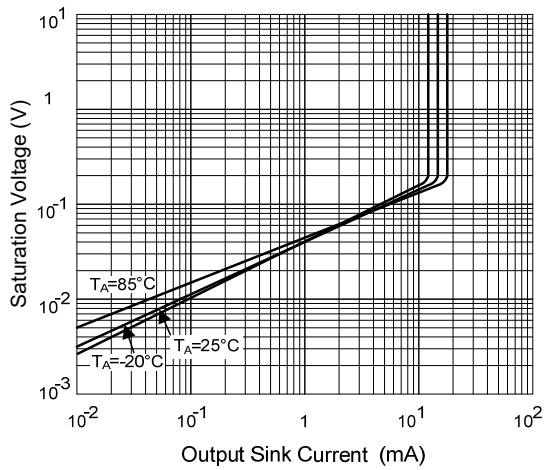

Fig.4 Reponse Time For Various Input Overdrive Negative Transition

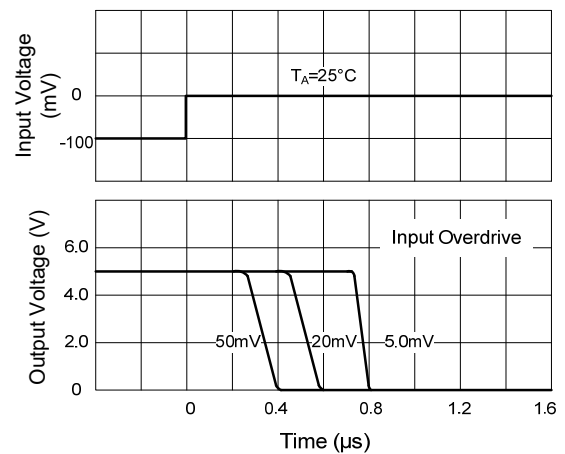
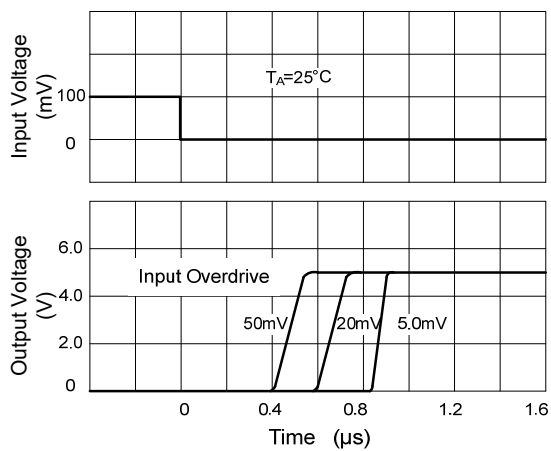

Fig.5 Reponse Time For Various Input Overdrive Positive Transition



UTC assumes no responsibility for equipment failures that result from using products at values that exceed, even momentarily, rated values (such as maximum ratings, operating condition ranges, or other parameters) listed in products specifications of any and all UTC products described or contained herein. UTC products are not designed for use in life support appliances, devices or systems where malfunction of these products can be reasonably expected to result in personal injury. Reproduction in whole or in part is prohibited without the prior written consent of the copyright owner. UTC reserves the right to make changes to information published in this document, including without limitation specifications and product descriptions, at any time and without notice. This document supersedes and replaces all information supplied prior to the publication hereof.