



## LR6401

CMOS IC

### DUAL CHANNEL LDO REGULATORS WITH ENABLE FUNCTION

#### DESCRIPTION

The UTC **LR6401** is a low noise and high accuracy LDO voltage regulator which has enable soft start function. Designers can reduce power consumption more easily by applying EN function that can turn off the output of each device and control the in rush current through the soft the start function.

The UTC **LR6401** comes with low design cost and outstanding output stability and its compatibility of working with low ESR ceramic capacitors is undoubted. Besides, and this level of stability is ensured by the perfect transient response and PSRR derived from a large frequency range.

#### FEATURES

- \*  $V_D=150mV @100mA$  (Typ.),  $V_{OUT} \geq 2.8V$
- \* Range of Operating Voltage:  $2.5V \sim 6.0V$
- \* Range of Output Voltage Range:  $1.2V \sim 4.0V$
- \* Range of Output Current:  $300mA / Channel$
- \* Low Power Consumption:  $30\mu A$  (Typ.) for Each Channel
- \* Standby Current:  $0.1\mu A$  (Typ.)
- \* Accurate :  $\pm 2\%$
- \* High PSRR: 65 dB
- \* Each Channel Output Current Limit Protection:  $450mA$
- \* With Short Circuit Protection
- \* Output ON/OFF Control Function

#### ORDERING INFORMATION

Ordering Number		Package	Packing
Lead Free	Halogen Free		
LR6401xL-AL6-R	LR6401xG-AG6-R	SOT-26	Tape Reel
LR6401xL-K06-1820U-R	LR6401xG-K06-1820U-R	UDFN1820-6	Tape Reel
LR6401xL-K06-1820X2-R	LR6401xG-K06-1820X2-R	X2DFN1820-6	Tape Reel

Note: x: Output Voltage, refer to Marking Information.

<p>LR6401xG-AG6-R</p>	<p>(1) R: Tape Reel  (2) AG6: SOT-26, K06-1820U: UDFN1820-6  K06-1820X2: X2DFN1820-6  (3) G: Halogen Free and Lead Free, L: Lead Free  (4) x: Refer to Marking Information</p>
-----------------------	--

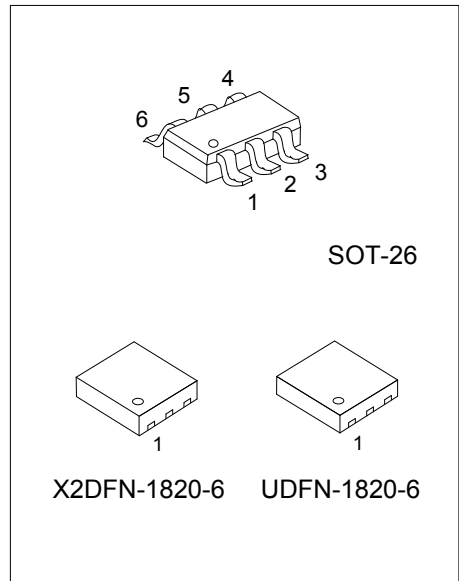

## MARKING INFORMATION

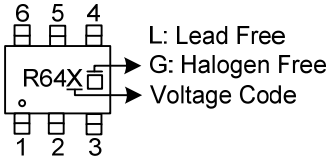
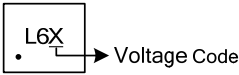
PACKAGE	VOLTAGE	VOLTAGE CODE	MARKING
SOT-26	1.8V + 3.3V 1.8V + 2.8V 2.5V + 3.3V 2.8V + 3.3V 2.8V + 1.8V	A B C D E	
UDFN1820-6 X2DFN1820-6	3.3V + 2.8V 2.85V + 2.85V 1.2V + 2.8V 1.5V + 2.8V 1.2V + 1.8V	F H M N P	

## PIN CONFIGURATION

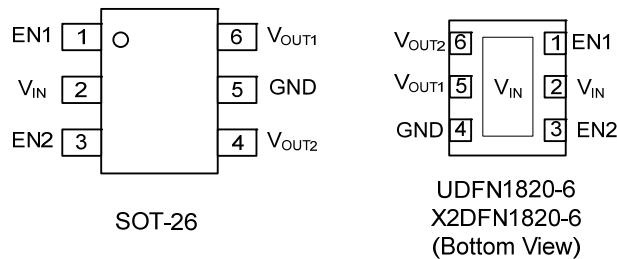

## PIN DESCRIPTION

PIN NO.		PIN NAME	DESCRIPTION
SOT-26	UDFN1820-6 X2DFN1820-6		
1	1	EN1	Channel 1's output enable control Pin
2	2	V <sub>IN</sub>	Voltage Input pin
3	3	EN2	Channel 2's output enable control Pin
4	6	V <sub>OUT2</sub>	Channel 2's voltage output
5	4	GND	Ground
6	5	V <sub>OUT1</sub>	Channel 1's voltage output
-	Exposed Pad	V <sub>IN</sub>	Connect exposed pad to V <sub>IN</sub> .

## ■ BLOCK DIAGRAM

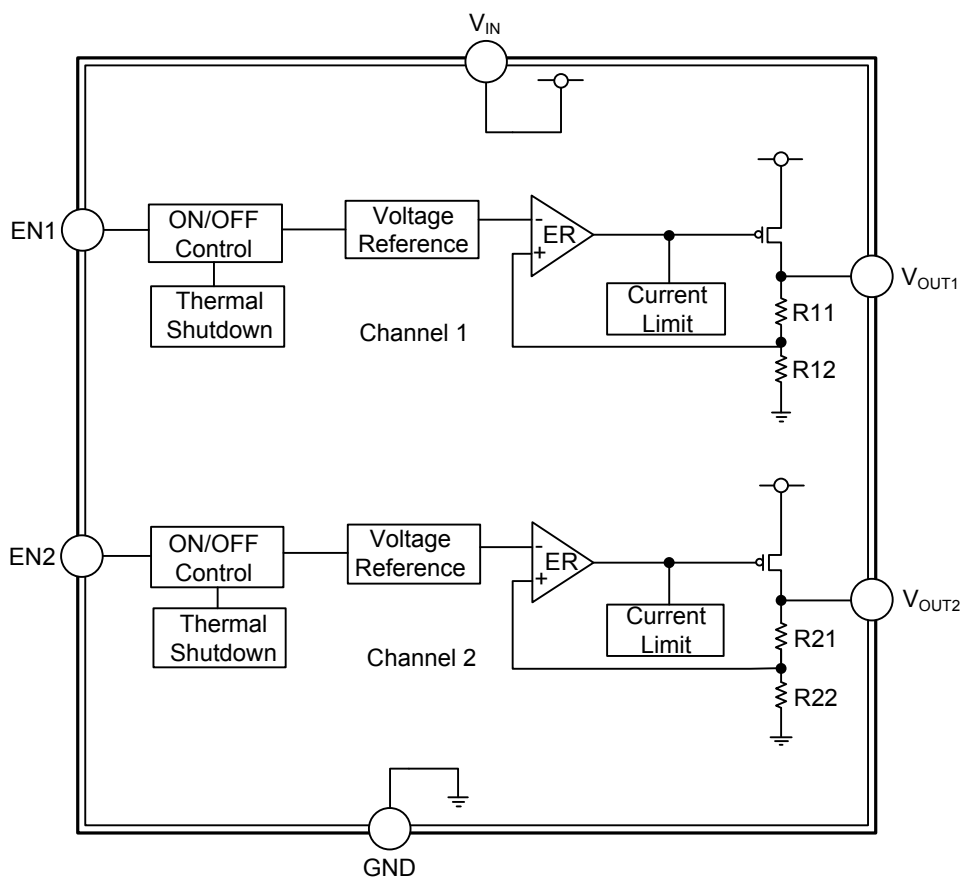

## ■ ABSOLUTE MAXIMUM RATING

PARAMETER		SYMBOL	RATINGS	UNIT
Input Voltage		$V_{IN}$	7.0	V
EN Pin Voltage		$V_{EN}$	$V_{SS}-0.3 \sim V_{IN}+0.3$	V
Output Voltage		$V_{OUT}$	$V_{SS}-0.3 \sim V_{IN}+0.3$	V
Output Current		$I_{OUT1}+I_{OUT2}$	700	mA
Power Dissipation	SOT-26	$P_D$	400	mW
	UDFN1820-6		1000 (Note 2)	
	X2DFN1820-6			
Junction Temperature		$T_J$	150	°C
Operating Temperature		$T_{OPR}$	-40 ~ +85	°C
Storage Temperature		$T_{STG}$	-55 ~ +125	°C

Notes: 1. Absolute maximum ratings are those values beyond which the device could be permanently damaged. Absolute maximum ratings are stress ratings only and functional device operation is not implied.  
 2. The data tested by surface mounted on a 2 inch<sup>2</sup> FR-4 board with 2OZ copper.

## ■ THERMAL DATA

PARAMETER		SYMBOL	RATINGS	UNIT
Junction to Ambient	SOT-26	$\theta_{JA}$	250	°C/W
	UDFN1820-6		100 (Note)	
	X2DFN1820-6			

Note: The data tested by surface mounted on a 2 inch<sup>2</sup> FR-4 board with 2OZ copper.

## ■ ELECTRICAL CHARACTERISTICS ( $T_A = 25^\circ\text{C}$ , unless otherwise specified.) (Note 3)

PARAMETER	SYMBOL	TEST CONDITIONS	MIN	TYP	MAX	UNIT
Input Voltage	$V_{IN}$		2.5		6.0	V
Output Voltage	$V_{OUT}$	$V_{IN}=V_{OUT}+1.0V, I_{OUT}=30mA$	$V_{OUT} \times 0.98$	$V_{OUT}$	$V_{OUT} \times 1.02$	V
Line Regulation	$\frac{\Delta V_{OUT}}{\Delta V_{IN} \times V_{OUT}}$	$V_{OUT}+1.0V \leq V_{IN} \leq 6.0V$ $I_{OUT}=1mA$		0.02	0.1	%/V
Load Regulation	$\Delta V_{OUT}$	$V_{IN}=V_{OUT}+1.0V,$ $1mA \leq I_{OUT} \leq 150mA$		13	60	mV
		$V_{IN}=V_{OUT}+1.0V,$ $1mA \leq I_{OUT} \leq 300mA$		30	90	mV
Output Current	$I_{OUT}$	$V_{OUT}+1.0V \leq V_{IN} \leq 6V$ (Note 1)		300		mA
Supply Current	$I_{SS}$	$V_{IN}=V_{EN}=V_{OUT}+1.0V, I_{OUT}=0mA$		60	90	μA
Standby Current	$I_{STN-BY}$	$V_{IN}=V_{OUT}+1.0V, V_{EN}=V_{SS}$		0.1	1	μA
Current Limite	$I_{LIMIT}$	$V_{IN}=V_{OUT}+1.0V, V_{IN}=V_{EN}$		450		mA
Short-Circuit Current	$I_{SC}$	$V_{IN}=V_{OUT}+1.0V, V_{IN}=V_{EN}$		150		mA
Dropout Voltage	$V_D$	$I_{OUT}=100mA$	$V_{OUT}=1.2V$	310	350	mV
			$V_{OUT}>1.2V$	150	250	mV
		$I_{OUT}=300mA$		450	750	mV
EN Pin Input Voltage	High	$V_{IH}$	(Note 2)	1.2		V
	Low	$V_{IL}$	(Note 2)		0.4	V
Temperature Coefficient of Output Voltage	$T_C V_O$	$I_{OUT}=30mA, -25^\circ\text{C} \leq T_{OPR} \leq +85^\circ\text{C}$		±100		ppm/°C
Over Temperature Shutdown	OTS			150		°C
Over Temperature Hysteresis	OTH			40		°C
Power Supply Rejection Rate	PSRR	$I_{OUT}=30mA, F=100Hz$		65		dB

Notes: 1. Measured using a double sided board with 1" x 2" square inches of copper area connected to the GND pins for "heat spreading".  
 2. EN pin input voltage must be always less than or equal to input voltage.  
 3. The minimum operating  $V_{IN}$  Value is equal to  $[V_{OUT} (NOM) + V_{DROPOUT}]$  or 2.5V, just the greater.

## ■ TYPICAL APPLICATION CIRCUIT

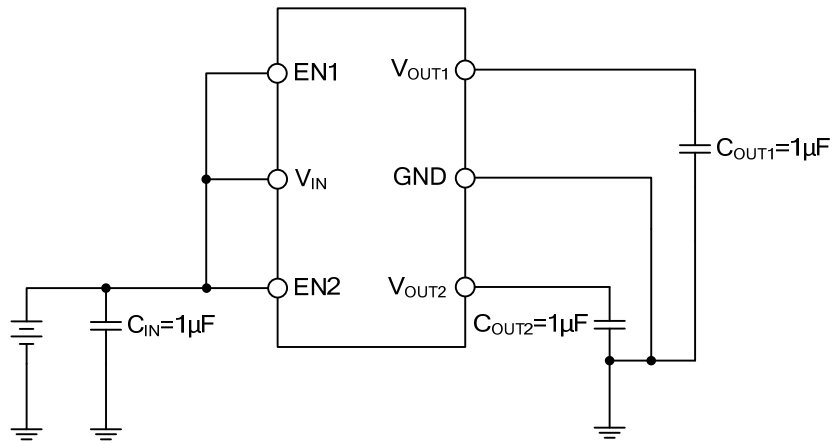

## TYPICAL CHARACTERISTICS

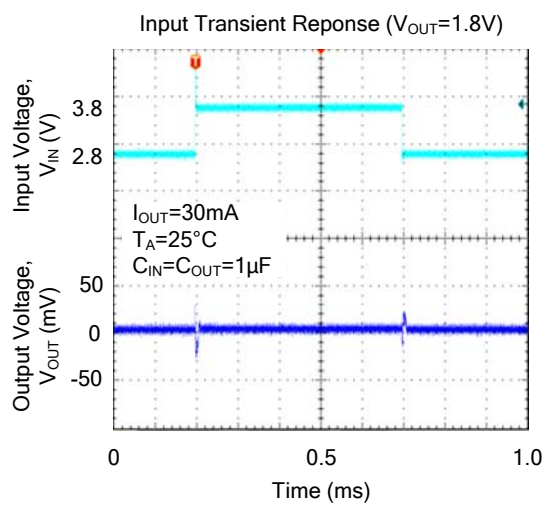
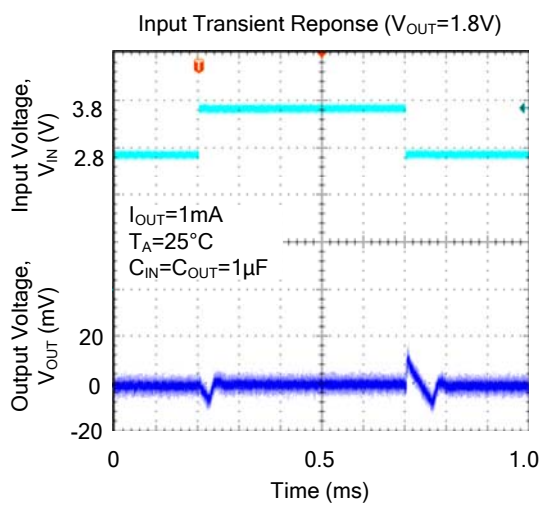
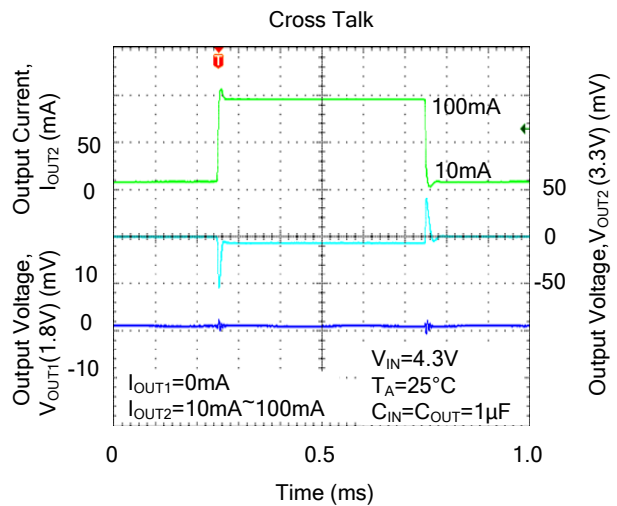
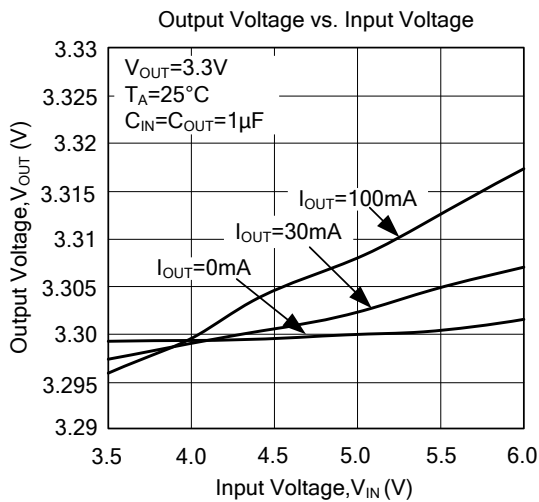
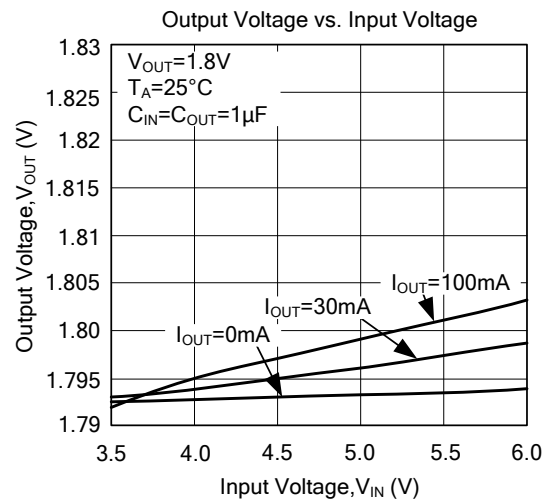
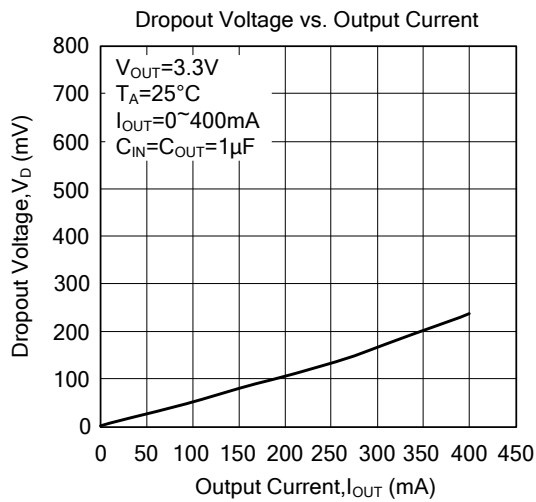

## ■ TYPICAL CHARACTERISTICS(Cont.)

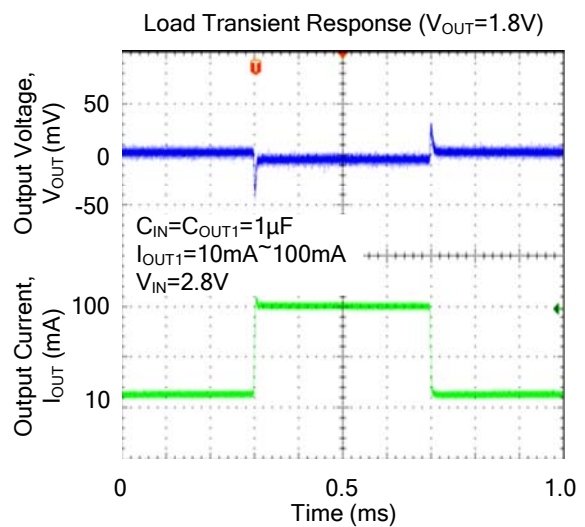
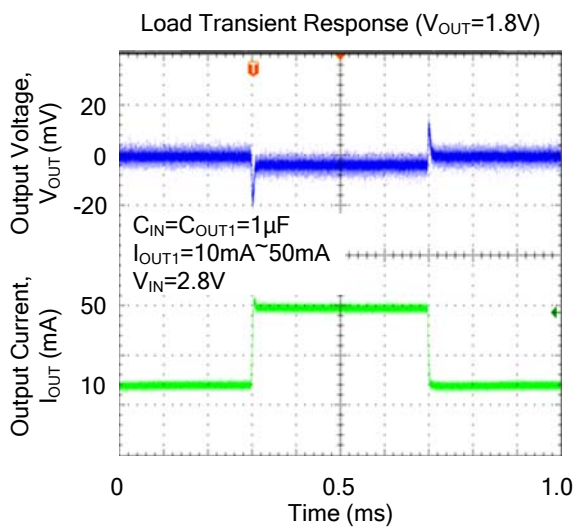
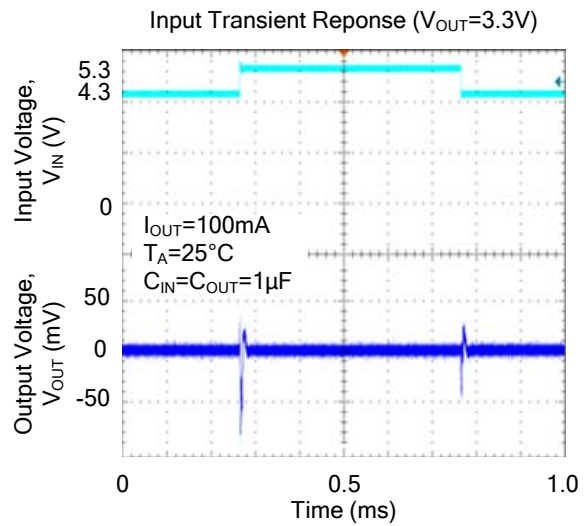
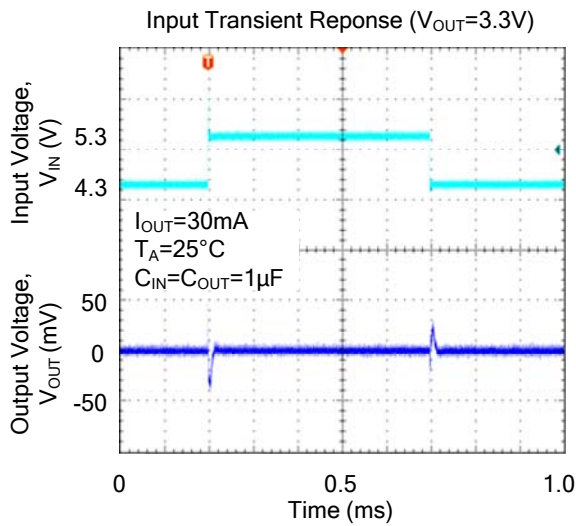
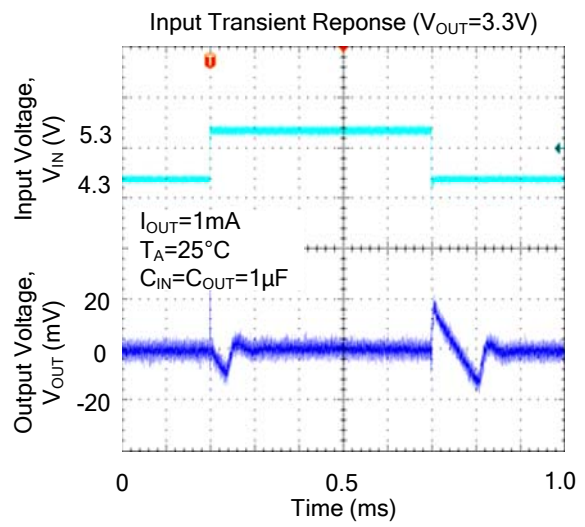
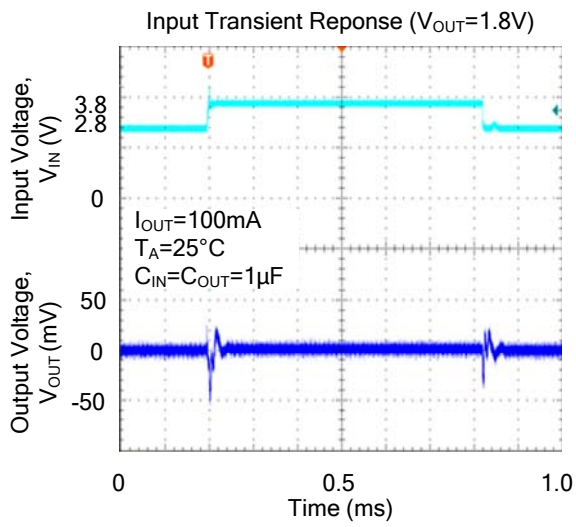

■ TYPICAL CHARACTERISTICS(Cont.)

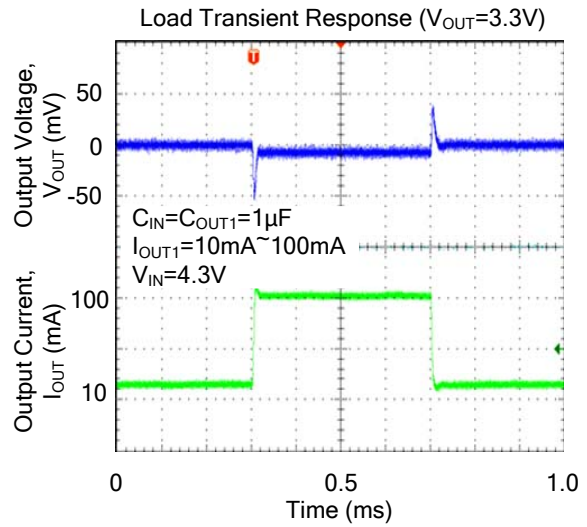
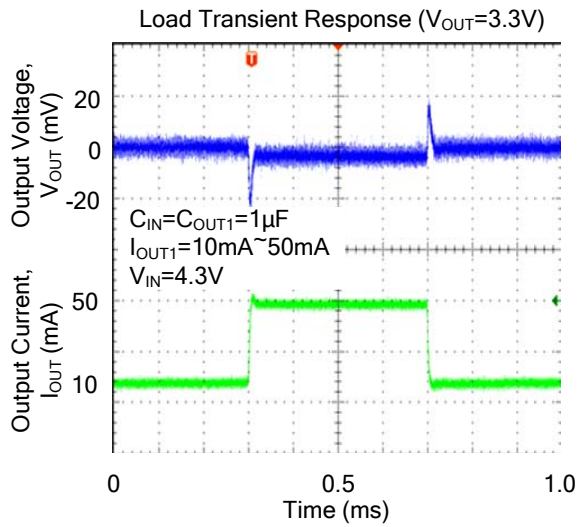

UTC assumes no responsibility for equipment failures that result from using products at values that exceed, even momentarily, rated values (such as maximum ratings, operating condition ranges, or other parameters) listed in products specifications of any and all UTC products described or contained herein. UTC products are not designed for use in life support appliances, devices or systems where malfunction of these products can be reasonably expected to result in personal injury. Reproduction in whole or in part is prohibited without the prior written consent of the copyright owner. UTC reserves the right to make changes to information published in this document, including without limitation specifications and product descriptions, at any time and without notice. This document supersedes and replaces all information supplied prior to the publication hereof.