



RXXLD30

Linear Integrated Circuit

**3A OUTPUT TYPE LOW
POWER-LOSS VOLTAGE
REGULATOR**

■ **FEATURES**

- *Low power-loss(Dropout voltage: 0.5V (max.) at Io=3.0A)
- *3.0A output type
- *Output voltage precision:±3.0%
- *Built-in ON/OFF control function and over-current protection circuit.
- *Thermal shutdown protection.

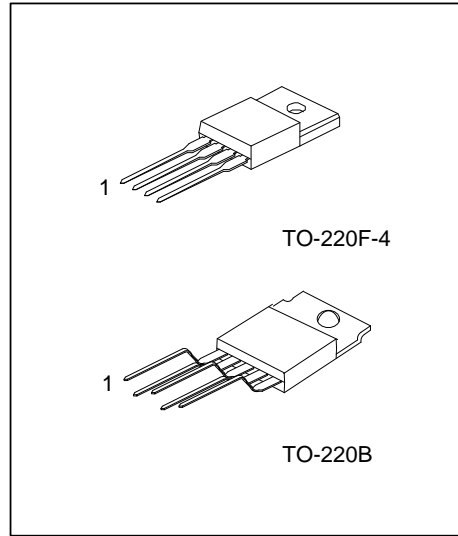

■ **ORDERING INFORMATION**

Ordering Number		Package	Pin Assignment					Packing
Lead Free	Halogen Free		1	2	3	4	5	
RXXLD30L-TB5-T	RXXLD30G-TB5-T	TO-220B	N	I	O	G	F	Tube
RXXLD30L-TF4-T	RXXLD30G-TF4-T	TO-220F-4	I	O	G	F	-	Tube

Note: Pin Assignment: N: NC I: INPUT O: OUTPUT G: GND F: ON/OFF

<p>RXXLD30G-TB5-T</p>	<p>(1) T: Tube (2) TB5: TO-220B, TF4: TO-220F-4 (3) G: Halogen Free and Lead Free, L: Lead Free (4) XX: refer to Marking Information</p>
-----------------------	--

■ ABSOLUTE MAXIMUM RATINGS (T_A=25°C, unless otherwise specified.)

PARAMETER		SYMBOL	RATINGS	UNIT
Input Voltage		V _{IN}	20	V
ON/OFF Control Terminal Voltage		V _C	20	V
Output Current		I _{OUT}	3.0	A
Power Dissipation	No Heat Sink	P _D	1.4	W
	With Heat Sink		15	W
Junction Temperature		T _J	+150	°C
Operating Temperature		T _{OPR}	-40 ~ +85	°C
Storage Temperature		T _{STG}	-40 ~ +150	°C

Notes: 1. Absolute maximum ratings are those values beyond which the device could be permanently damaged.

Absolute maximum ratings are stress ratings only and functional device operation is not implied.

2. All are open except GND and applicable terminals.

3. This condition is only determined from design. It can't be 100% tested in mass production.

■ THERMAL DATA

PARAMETER	SYMBOL	RATING	UNIT
Junction to Ambient	θ _{JA}	89.3	°C/W
Junction to Case	θ _{JC}	8.3	°C/W

■ ELECTRICAL CHARACTERISTICS (Refer to the test circuits, unless otherwise specified, T_A=25°C)

For R33LD30(3.3V)

PARAMETER	SYMBOL	TEST CONDITIONS	MIN	TYP	MAX	UNIT
Output Voltage	V _{OUT}	V _{IN} =5V, I _{OUT} =2A	3.201	3.3	3.399	V
Line Regulation	ΔV _{OUT}	V _{IN} =4 ~ 10V, I _{OUT} =5mA		0.1	2.5	%
Load Regulation	ΔV _{OUT}	V _{IN} =5V, I _{OUT} =5mA ~ 3.0A		0.1	2.0	%
Temperature Coefficient of Output Voltage	TcVo	T _J =0 ~ 125°C, I _{OUT} =5mA		±0.02		%/°C
Ripple Rejection	RR	Refer to Fig.2	45	55		dB
Dropout Voltage	V _D	(Note1), I _{OUT} =3A			0.5	V
Voltage for Control(Note2)	ON	V _{C(ON)} V _{IN} =5V	2.0			V
	OFF	V _{C(OFF)} V _{IN} =5V			0.8	V
Current for Control	ON	I _{C(ON)} V _C =2.7V, V _{IN} =5V			20	μA
	OFF	I _{C(OFF)} V _C =0.4V, V _{IN} =5V			-0.4	mA
Quiescent Current	I _D	I _{OUT} =0A, V _{IN} =5V			10	mA

For R05LD30(5V)

PARAMETER	SYMBOL	TEST CONDITIONS	MIN	TYP	MAX	UNIT
Output Voltage	V _{OUT}	V _{IN} =7V, I _{OUT} =2A	4.85	5.0	5.15	V
Line Regulation	ΔV _{OUT}	V _{IN} =6 ~ 12V, I _{OUT} =5mA		0.5	2.5	%
Load Regulation	ΔV _{OUT}	V _{IN} =7V, I _{OUT} =5mA ~ 3.0A		0.1	2.0	%
Temperature Coefficient of Output Voltage	TcVo	T _J =0 ~ 125°C, I _{OUT} =5mA		±0.02		%/°C
Ripple Rejection	RR	Refer to Fig.2	45	55		dB
Dropout Voltage	V _D	(Note1), I _{OUT} =3A			0.5	V
Voltage for Control(Note2)	ON	V _{C(ON)} V _{IN} =7V	2.0			V
	OFF	V _{C(OFF)} V _{IN} =7V			0.8	V
Current for Control	ON	I _{C(ON)} V _C =2.7V, V _{IN} =7V			20	μA
	OFF	I _{C(OFF)} V _C =0.4V, V _{IN} =7V			-0.4	mA
Quiescent Current	I _D	I _{OUT} =0A, V _{IN} =7V			10	mA

■ ELECTRICAL CHARACTERISTICS (Cont.)

For R09LD30(9V)

PARAMETER	SYMBOL	TEST CONDITIONS	MIN	TYP	MAX	UNIT
Output Voltage	V_{OUT}	$V_{IN} = 11V, I_{OUT} = 2A$	8.73	9.0	9.27	V
Line Regulation	ΔV_{OUT}	$V_{IN} = 10 \sim 16V, I_{OUT} = 5mA$		0.5	2.5	%
Load Regulation	ΔV_{OUT}	$V_{IN} = 11V, I_{OUT} = 5mA \sim 3.0A$		0.1	2.0	%
Temperature Coefficient of Output Voltage	$TcVo$	$T_J = 0 \sim 125^\circ C, I_{OUT} = 5mA$		± 0.02		%/ $^\circ C$
Ripple Rejection	RR	Refer to Fig.2	45	55		dB
Dropout Voltage	V_D	(Note1), $I_{OUT} = 3A$			0.5	V
Voltage for Control(Note2)	ON	$V_{C(ON)}$	$V_{IN} = 11V$	2.0		V
	OFF	$V_{C(OFF)}$	$V_{IN} = 11V$		0.8	V
Current for Control	ON	$I_{C(ON)}$	$V_C = 2.7V, V_{IN} = 11V$		20	μA
	OFF	$I_{C(OFF)}$	$V_C = 0.4V, V_{IN} = 11V$		-0.4	mA
Quiescent Current	I_D	$I_{OUT} = 0A, V_{IN} = 11V$			10	mA

For R12LD30(12V)

PARAMETER	SYMBOL	TEST CONDITIONS	MIN	TYP	MAX	UNIT
Output Voltage	V_{OUT}	$V_{IN} = 14V, I_{OUT} = 2A$	11.64	12.0	12.36	V
Line Regulation	ΔV_{OUT}	$V_{IN} = 13 \sim 19V, I_{OUT} = 5mA$		0.5	2.5	%
Load Regulation	ΔV_{OUT}	$V_{IN} = 14V, I_{OUT} = 5mA \sim 3.0A$		0.1	2.0	%
Temperature Coefficient of Output Voltage	$TcVo$	$T_J = 0 \sim 125^\circ C, I_{OUT} = 5mA$		± 0.02		%/ $^\circ C$
Ripple Rejection	RR	Refer to Fig.2	45	55		dB
Dropout Voltage	V_D	(Note1), $I_{OUT} = 3A$			0.5	V
Voltage for Control(Note2)	ON	$V_{C(ON)}$	$V_{IN} = 14V$	2.0		V
	OFF	$V_{C(OFF)}$	$V_{IN} = 14V$		0.8	V
Current for Control	ON	$I_{C(ON)}$	$V_C = 2.7V, V_{IN} = 14V$		20	μA
	OFF	$I_{C(OFF)}$	$V_C = 0.4V, V_{IN} = 14V$		-0.4	mA
Quiescent Current	I_D	$I_{OUT} = 0A, V_{IN} = 14V$			10	mA

Note: 1. Input voltage shall be the value when output voltage is 95% in comparison with the initial value.

2. In case of opening control terminal (pin 5 of TO-220B, pin 4 of TO-220F-4), output voltage turns on.

TEST CIRCUIT

Note : ○: TO-220F-4, (): TO-220B

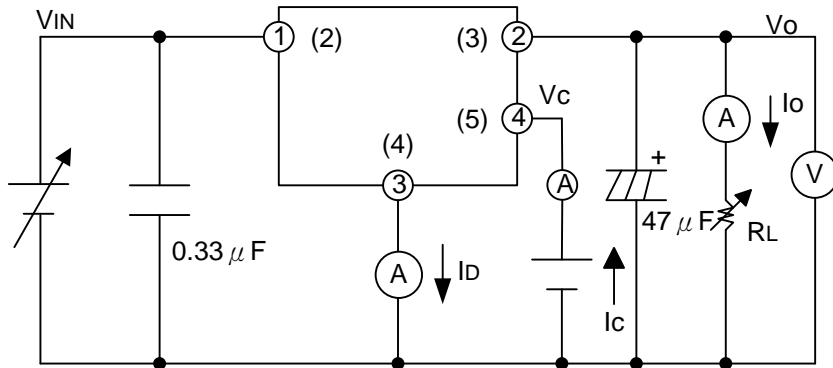
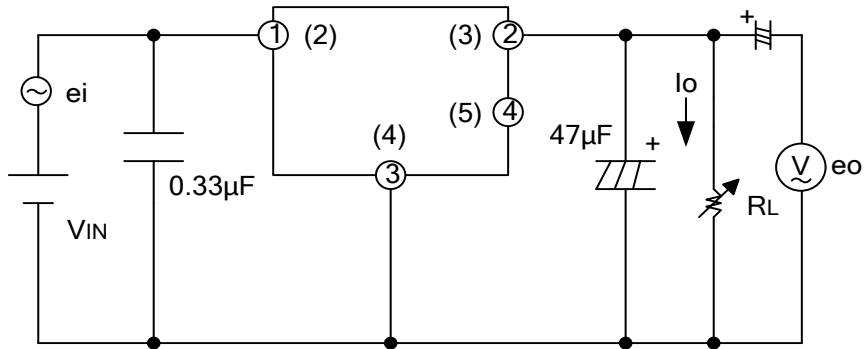

Fig.1



$V_{IN}=5V(R33LD30)$ $f=120Hz$
 $7V(R05LD30)$ $e_i=0.5V_{rms}$
 $11V(R09LD30)$ $I_o=0.5A$
 $14V(R12LD30)$ $RR=20\log(e_i/e_o)$

Fig.2 For Ripple Rejection

TYPICAL APPLICATION

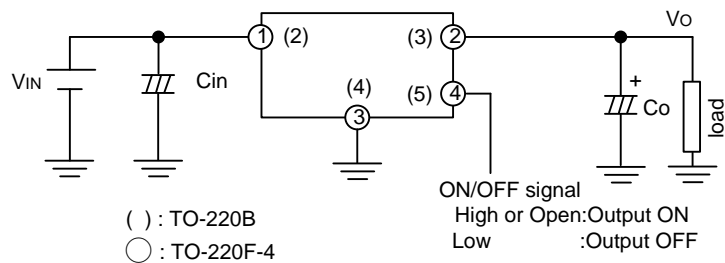

TYPICAL CHARACTERISTICS

Fig.3 Power Dissipation vs. Ambient Temperature

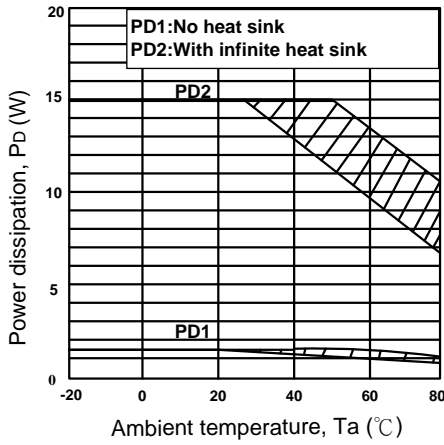

Note: Oblique line portion: Overheat protection may operate in this area.

Fig.4 Overcurrent Protection Characteristics(Typical Value) (R33LD30)

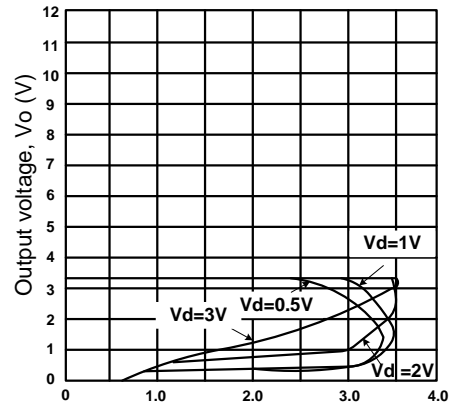

Fig.5 Overcurrent Protection Characteristics (Typical Value)(R05LD30)

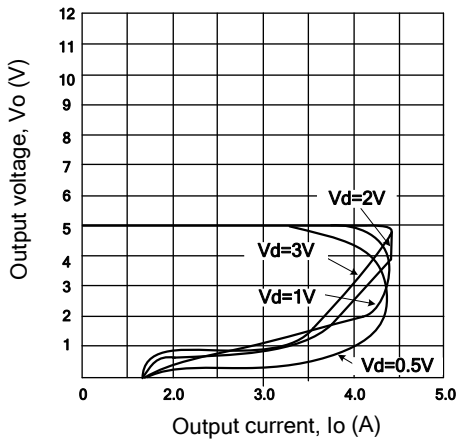

Fig.6 Overcurrent Protection Characteristics (Typical Value)(R09LD30)

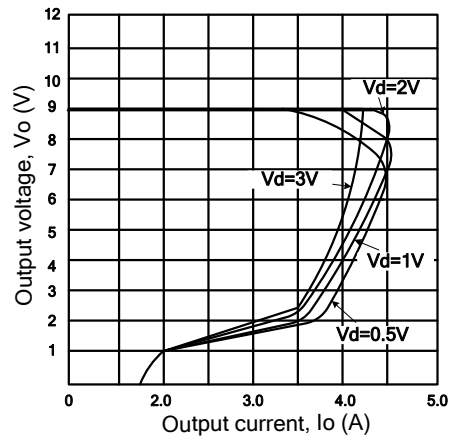

Fig.7 Overcurrent Protection Characteristics (Typical Value)(R12LD30)

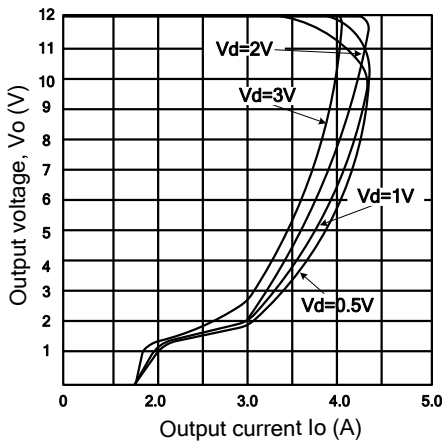
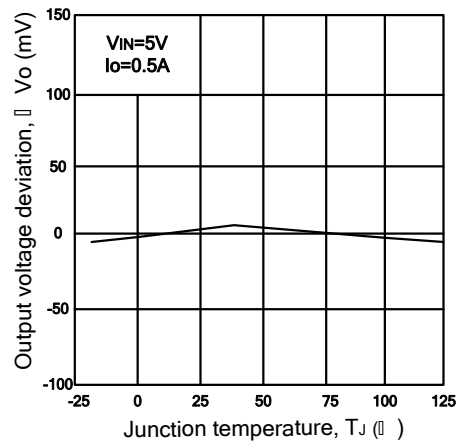

Fig.8 Output Voltage Deviation vs. Junction Temperature (R03LD30)



■ TYPICAL CHARACTERISTICS (cont.)

Fig.9 Output Voltage Deviation vs .Junction Temperature (R05LD30)

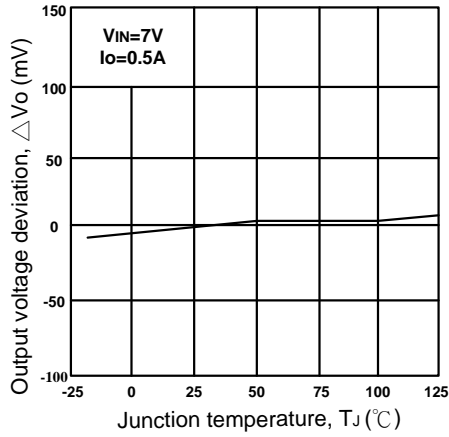

Fig.10 Output Voltage Deviation vs .Junction Temperature (R09LD30)

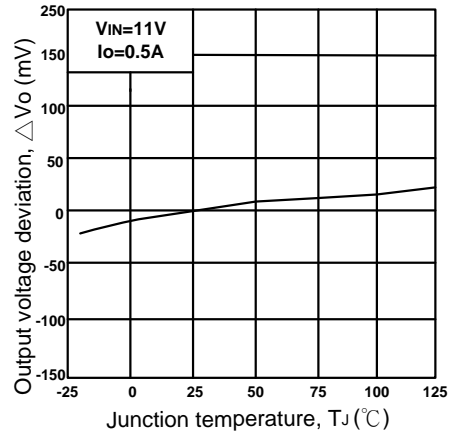

Fig.11 Output Voltage Deviation vs .Junction Temperature (R12LD30)

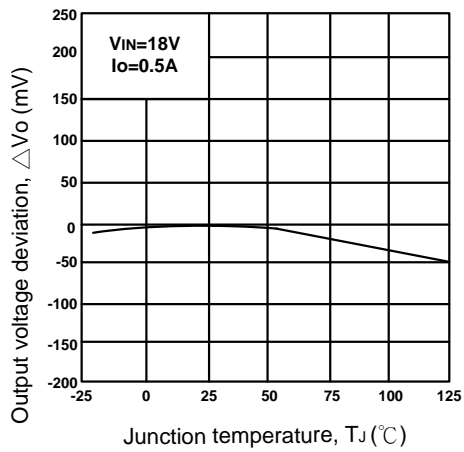

Fig.12 Output Voltage vs .Input Voltage (R33LD30)

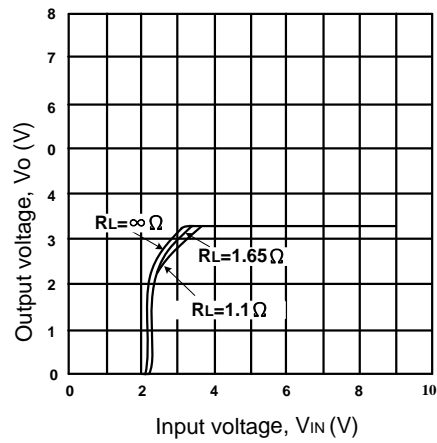

Fig.13 Output Voltage vs .Input Voltage (R05LD30)

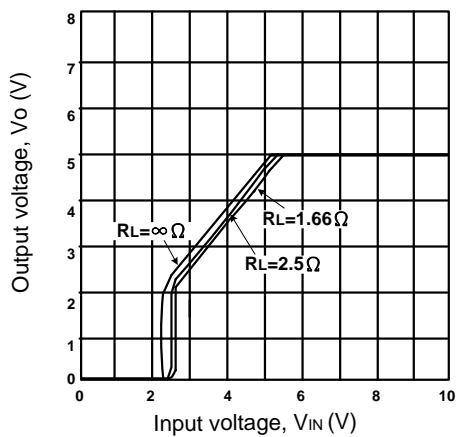
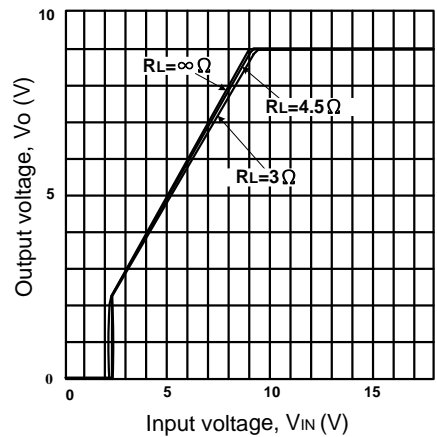

Fig.14 Output Voltage vs .Input Voltage (R09LD30)



■ TYPICAL CHARACTERISTICS (cont.)

Fig.15 Output Voltage vs .Input Voltage (R12LD30)

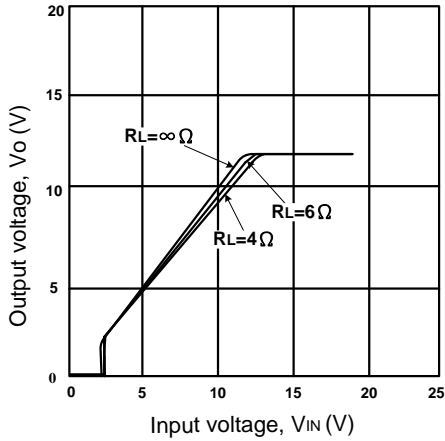

Fig.16 Circuit Operating Current vs .Input Voltage (R33LD30)

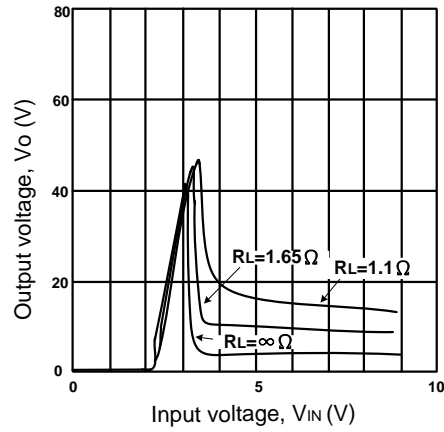

Fig.17 Circuit Operating Current vs .Input Voltage (R05LD30)

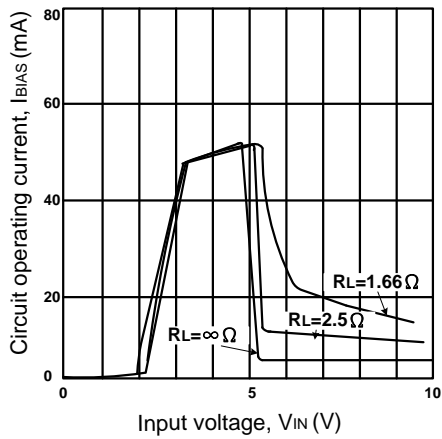

Fig.18 Circuit Operating Current vs .Input Voltage (R09LD30)

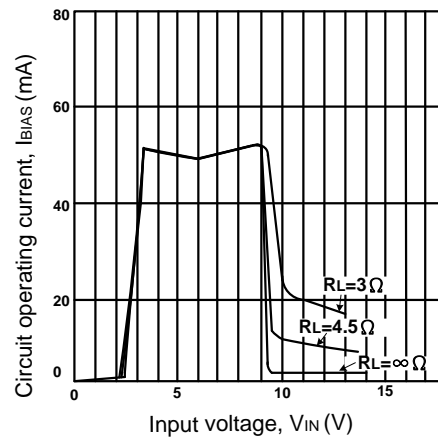

Fig.19 Circuit Operating Current vs .Input Voltage (R12LD30)

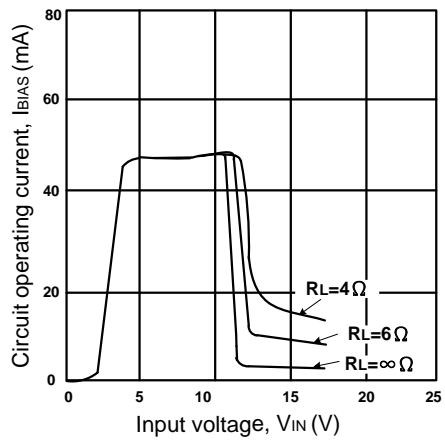
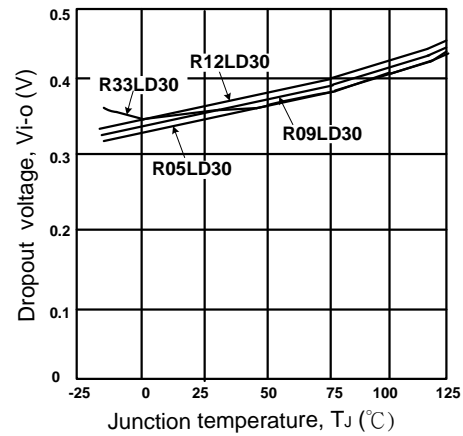

Fig.20 Dropout Voltage vs .Junction Temperature



■ TYPICAL CHARACTERISTICS (cont.)

Fig.21 Quiescent Current vs Junction Temperature

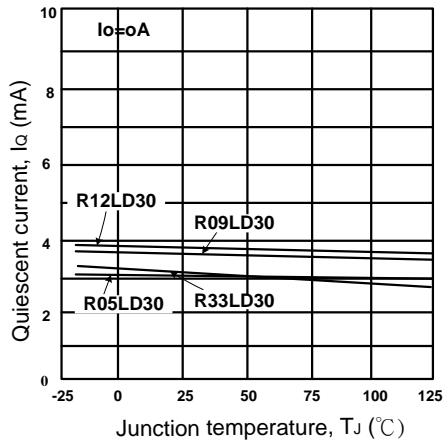
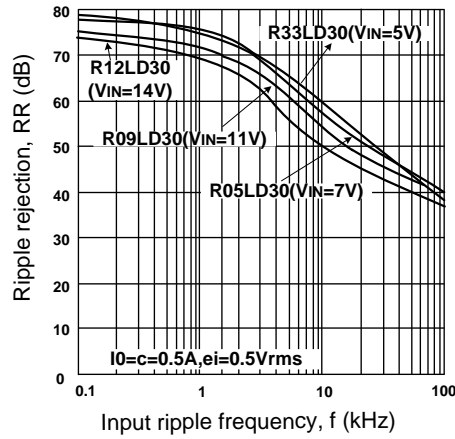

Fig.22 Ripple Rejection vs Input Ripple Frequency



UTC assumes no responsibility for equipment failures that result from using products at values that exceed, even momentarily, rated values (such as maximum ratings, operating condition ranges, or other parameters) listed in products specifications of any and all UTC products described or contained herein. UTC products are not designed for use in life support appliances, devices or systems where malfunction of these products can be reasonably expected to result in personal injury. Reproduction in whole or in part is prohibited without the prior written consent of the copyright owner. UTC reserves the right to make changes to information published in this document, including without limitation specifications and product descriptions, at any time and without notice. This document supersedes and replaces all information supplied prior to the publication hereof.