



RXXLD20

LINEAR INTEGRATED CIRCUIT

2A OUTPUT TYPE LOW POWER-LOSS VOLTAGE REGULATOR

FEATURES

- * Low power-loss(Dropout voltage: 0.5V (max.) at I_{OUT}=2.0A)
- * 2.0A output type
- * Output voltage precision: ±3.0%
- * Built-in ON/OFF control function and over-current protection circuit.
- * Thermal shutdown protection.

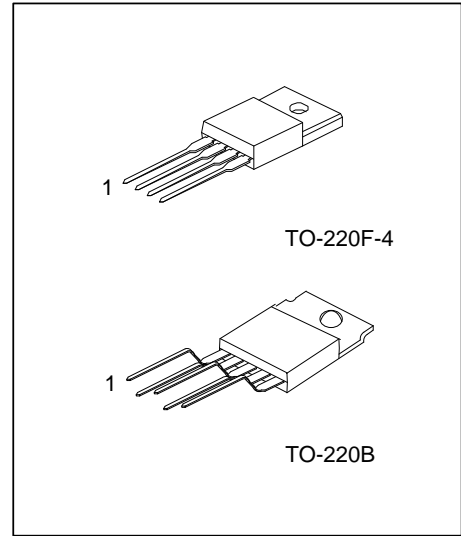

ORDERING INFORMATION

Ordering Number		Package	Pin Assignment					Packing
Lead Free	Halogen Free		1	2	3	4	5	
RXXLD20L-TB5-T	RXXLD20G-TB5-T	TO-220B	N	I	O	G	F	Tube
RXXLD20L-TF4-T	RXXLD20G-TF4-T	TO-220F-4	I	O	G	F	-	Tube

Note: Pin Assignment: N: NC I: INPUT O: OUTPUT G: GND F: ON/OFF

<p>RXXLD20G-TB5-T</p>	<p>(1) T: Tube (2) TB5: TO-220B, TF4: TO-220F-4 (3) G: Halogen Free and Lead Free, L: Lead Free (4) XX: refer to Marking Information</p>
-----------------------	---

MARKING INFORMATION

PACKAGE	VOLTAGE CODE	MARKING
TO-220F-4 TO-220B	33 :3.3V 35 :3.5V 05 :5.0V 06 :6.0V 08 :8.0V 09 :9.0V 10 :10V 12 :12V 15 :15V	

BLOCK DIAGRAM

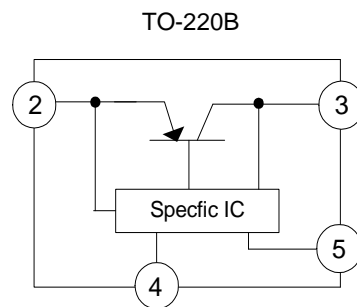
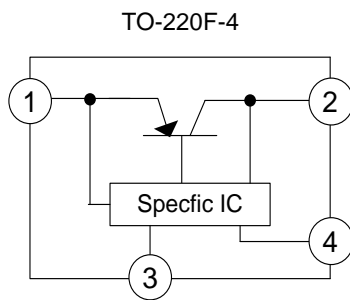

■ **ABSOLUTE MAXIMUM RATINGS** ($T_A=25^{\circ}\text{C}$, unless otherwise specified.)

PARAMETER	SYMBOL	RATINGS	UNIT
Input Voltage(Note1)	V_{IN}	20	V
ON/OFF Control Terminal Voltage (Note 2)	V_C	20	V
Output Current	I_{OUT}	2.0	A
Power Dissipation	No Heat Sink	P_D	1.4
	With Heat Sink		15
Junction Temperature	T_J	+150	$^{\circ}\text{C}$
Operating Temperature	T_{OPR}	-40 ~ +85	$^{\circ}\text{C}$
Storage Temperature	T_{STG}	-40 ~ +150	$^{\circ}\text{C}$

Notes: 1. Absolute maximum ratings are those values beyond which the device could be permanently damaged.

Absolute maximum ratings are stress ratings only and functional device operation is not implied.

2. All are open except GND and applicable terminals.

3. This condition is only determined from design. It can't be 100% tested in mass production.

■ **THERMAL DATA**

PARAMETER	SYMBOL	RATING	UNIT
Junction to Ambient	θ_{JA}	89.3	$^{\circ}\text{C}/\text{W}$
Junction to Case	θ_{JC}	8.3	$^{\circ}\text{C}/\text{W}$

■ **ELECTRICAL CHARACTERISTICS** (Refer to the test circuits, unless otherwise specified, $T_A=25^{\circ}\text{C}$)

For R33LD20(3.3V)

PARAMETER	SYMBOL	TEST CONDITIONS	MIN	TYP	MAX	UNIT
Output Voltage	V_{OUT}	$V_{IN}=5\text{V}, I_{OUT}=1\text{A}$	3.201	3.3	3.399	V
Line Regulation	ΔV_{OUT}	$V_{IN}=4 \sim 10\text{V}, I_{OUT}=5\text{mA}$		0.1	2.5	%
Load Regulation	ΔV_{OUT}	$V_{IN}=5\text{V}, I_{OUT}=5\text{mA} \sim 2.0\text{A}$		0.1	2.0	%
Temperature Coefficient of Output Voltage	$T_C V_O$	$T_J=0 \sim 125^{\circ}\text{C}, I_{OUT}=5\text{mA}$		± 0.02		$\%/^{\circ}\text{C}$
Ripple Rejection	RR	Refer to Fig.2	45	55		dB
Dropout Voltage	V_D	(Note 1), $I_{OUT}=2\text{A}$			0.5	V
Voltage for Control(Note 2)	ON	$V_{C(ON)}$	$V_{IN}=5\text{V}$	2.0		V
	OFF	$V_{C(OFF)}$	$V_{IN}=5\text{V}$		0.8	V
Current for Control	ON	$I_{C(ON)}$	$V_C=2.7\text{V}, V_{IN}=5\text{V}$		20	μA
	OFF	$I_{C(OFF)}$	$V_C=0.4\text{V}, V_{IN}=5\text{V}$		-0.4	mA
Quiescent Current	I_Q	$I_{OUT}=0\text{A}, V_{IN}=5\text{V}$			10	mA

For R35LD20(3.5V)

PARAMETER	SYMBOL	TEST CONDITIONS	MIN	TYP	MAX	UNIT
Output Voltage	V_{OUT}	$V_{IN}=5.5\text{V}, I_{OUT}=1\text{A}$	3.395	3.5	3.605	V
Line Regulation	ΔV_{OUT}	$V_{IN}=4.5 \sim 10.5\text{V}, I_{OUT}=5\text{mA}$		0.1	2.5	%
Load Regulation	ΔV_{OUT}	$V_{IN}=5.5\text{V}, I_{OUT}=5\text{mA} \sim 2.0\text{A}$		0.1	2.0	%
Temperature Coefficient of Output Voltage	$T_C V_O$	$T_J=0 \sim 125^{\circ}\text{C}, I_{OUT}=5\text{mA}$		± 0.02		$\%/^{\circ}\text{C}$
Ripple Rejection	RR	Refer to Fig.2	45	55		dB
Dropout Voltage	V_D	(Note 1), $I_{OUT}=2\text{A}$			0.5	V
Voltage for Control (Note 2)	ON	$V_{C(ON)}$	$V_{IN}=5\text{V}$	2.0		V
	OFF	$V_{C(OFF)}$	$V_{IN}=5\text{V}$		0.8	V
Current for Control	ON	$I_{C(ON)}$	$V_C=2.7\text{V}, V_{IN}=5.5\text{V}$		20	μA
	OFF	$I_{C(OFF)}$	$V_C=0.4\text{V}, V_{IN}=5.5\text{V}$		-0.4	mA
Quiescent Current	I_Q	$I_{OUT}=0\text{A}, V_{IN}=5.5\text{V}$			10	mA

■ ELECTRICAL CHARACTERISTICS (Cont.)

For R05LD20(5V)

PARAMETER	SYMBOL	TEST CONDITIONS	MIN	TYP	MAX	UNIT
Output Voltage	V_{OUT}	$V_{IN}=7V, I_{OUT}=1A$	4.85	5.0	5.15	V
Line Regulation	ΔV_{OUT}	$V_{IN}=6 \sim 12V, I_{OUT}=5mA$		0.5	2.5	%
Load Regulation	ΔV_{OUT}	$V_{IN}=7V, I_{OUT}=5mA \sim 2.0A$		0.1	2.0	%
Temperature Coefficient of Output Voltage	$T_C V_O$	$T_J=0 \sim 125^\circ C, I_{OUT}=5mA$		± 0.02		%/ $^\circ C$
Ripple Rejection	RR	Refer to Fig.2	45	55		dB
Dropout Voltage	V_D	(Note 1), $I_{OUT}=2A$			0.5	V
Voltage for Control (Note 2)	ON	$V_{C(ON)}$ $V_{IN}=7V$	2.0			V
	OFF	$V_{C(OFF)}$ $V_{IN}=7V$			0.8	V
Current for Control	ON	$I_{C(ON)}$ $V_C=2.7V, V_{IN}=7V$			20	μA
	OFF	$I_{C(OFF)}$ $V_C=0.4V, V_{IN}=7V$			-0.4	mA
Quiescent Current	I_Q	$I_{OUT}=0A, V_{IN}=7V$			10	mA

For R06LD20(6V)

PARAMETER	SYMBOL	TEST CONDITIONS	MIN	TYP	MAX	UNIT
Output Voltage	V_{OUT}	$V_{IN}=8V, I_{OUT}=1A$	5.82	6.0	6.18	V
Line Regulation	ΔV_{OUT}	$V_{IN}=7 \sim 13V, I_{OUT}=5mA$		0.5	2.5	%
Load Regulation	ΔV_{OUT}	$V_{IN}=8V, I_{OUT}=5mA \sim 2.0A$		0.1	2.0	%
Temperature Coefficient of Output Voltage	$T_C V_O$	$T_J=0 \sim 125^\circ C, I_{OUT}=5mA$		± 0.02		%/ $^\circ C$
Ripple Rejection	RR	Refer to Fig.2	45	55		dB
Dropout Voltage	V_D	(Note 1), $I_{OUT}=2A$			0.5	V
Voltage for Control (Note 2)	ON	$V_{C(ON)}$ $V_{IN}=8V$	2.0			V
	OFF	$V_{C(OFF)}$ $V_{IN}=8V$			0.8	V
Current for Control	ON	$I_{C(ON)}$ $V_C=2.7V, V_{IN}=8V$			20	μA
	OFF	$I_{C(OFF)}$ $V_C=0.4V, V_{IN}=8V$			-0.4	mA
Quiescent Current	I_Q	$I_{OUT}=0A, V_{IN}=8V$			10	mA

For R08LD20(8V)

PARAMETER	SYMBOL	TEST CONDITIONS	MIN	TYP	MAX	UNIT
Output Voltage	V_{OUT}	$V_{IN}=10V, I_{OUT}=1A$	7.76	8.0	8.24	V
Line Regulation	ΔV_{OUT}	$V_{IN}=9 \sim 15V, I_{OUT}=5mA$		0.5	2.5	%
Load Regulation	ΔV_{OUT}	$V_{IN}=10V, I_{OUT}=5mA \sim 2.0A$		0.1	2.0	%
Temperature Coefficient of Output Voltage	$T_C V_O$	$T_J=0 \sim 125^\circ C, I_{OUT}=5mA$		± 0.02		%/ $^\circ C$
Ripple Rejection	RR	Refer to Fig.2	45	55		dB
Dropout Voltage	V_D	(Note 1), $I_{OUT}=2A$			0.5	V
Voltage for Control (Note 2)	ON	$V_{C(ON)}$ $V_{IN}=10V$	2.0			V
	OFF	$V_{C(OFF)}$ $V_{IN}=10V$			0.8	V
Current for Control	ON	$I_{C(ON)}$ $V_C=2.7V, V_{IN}=10V$			20	μA
	OFF	$I_{C(OFF)}$ $V_C=0.4V, V_{IN}=10V$			-0.4	mA
Quiescent Current	I_Q	$I_{OUT}=0A, V_{IN}=10V$			10	mA

■ ELECTRICAL CHARACTERISTICS(Cont.)

For R09LD20(9V)

PARAMETER	SYMBOL	TEST CONDITIONS	MIN	TYP	MAX	UNIT
Output Voltage	V_{OUT}	$V_{IN}=11V, I_{OUT}=1A$	8.73	9.0	9.27	V
Line Regulation	ΔV_{OUT}	$V_{IN}=10\sim 16V, I_{OUT}=5mA$		0.5	2.5	%
Load Regulation	ΔV_{OUT}	$V_{IN}=11V, I_{OUT}=5mA\sim 2.0A$		0.1	2.0	%
Temperature Coefficient of Output Voltage	$T_C V_O$	$T_J=0\sim 125^\circ C, I_{OUT}=5mA$		± 0.02		%/ $^\circ C$
Ripple Rejection	RR	Refer to Fig.2	45	55		dB
Dropout Voltage	V_D	(Note 1), $I_{OUT}=2A$			0.5	V
Voltage for Control (Note 2)	ON	$V_{C(ON)}$	$V_{IN}=11V$	2.0		V
	OFF	$V_{C(OFF)}$	$V_{IN}=11V$		0.8	V
Current for Control	ON	$I_{C(ON)}$	$V_C=2.7V, V_{IN}=11V$		20	μA
	OFF	$I_{C(OFF)}$	$V_C=0.4V, V_{IN}=11V$		-0.4	mA
Quiescent Current	I_Q	$I_{OUT}=0A, V_{IN}=11V$			10	mA

For R10LD20(10V)

PARAMETER	SYMBOL	TEST CONDITIONS	MIN	TYP	MAX	UNIT
Output Voltage	V_{OUT}	$V_{IN}=12V, I_{OUT}=1A$	9.7	10.0	10.3	V
Line Regulation	ΔV_{OUT}	$V_{IN}=11\sim 17V, I_{OUT}=5mA$		0.5	2.5	%
Load Regulation	ΔV_{OUT}	$V_{IN}=12V, I_{OUT}=5mA\sim 2.0A$		0.1	2.0	%
Temperature Coefficient of Output Voltage	$T_C V_O$	$T_J=0\sim 125^\circ C, I_{OUT}=5mA$		± 0.02		%/ $^\circ C$
Ripple Rejection	RR	Refer to Fig.2	45	55		dB
Dropout Voltage	V_D	(Note 1), $I_{OUT}=2A$			0.5	V
Voltage for Control (Note 2)	ON	$V_{C(ON)}$	$V_{IN}=12V$	2.0		V
	OFF	$V_{C(OFF)}$	$V_{IN}=12V$		0.8	V
Current for Control	ON	$I_{C(ON)}$	$V_C=2.7V, V_{IN}=12V$		20	μA
	OFF	$I_{C(OFF)}$	$V_C=0.4V, V_{IN}=12V$		-0.4	mA
Quiescent Current	I_Q	$I_{OUT}=0A, V_{IN}=12V$			10	mA

For R12LD20(12V)

PARAMETER	SYMBOL	TEST CONDITIONS	MIN	TYP	MAX	UNIT
Output Voltage	V_{OUT}	$V_{IN}=14V, I_{OUT}=1A$	11.64	12.0	12.36	V
Line Regulation	ΔV_{OUT}	$V_{IN}=13\sim 19V, I_{OUT}=5mA$		0.5	2.5	%
Load Regulation	ΔV_{OUT}	$V_{IN}=14V, I_{OUT}=5mA\sim 2.0A$		0.1	2.0	%
Temperature Coefficient of Output Voltage	$T_C V_O$	$T_J=0\sim 125^\circ C, I_{OUT}=5mA$		± 0.02		%/ $^\circ C$
Ripple Rejection	RR	Refer to Fig.2	45	55		dB
Dropout Voltage	V_D	(Note 1), $I_{OUT}=2A$			0.5	V
Voltage for Control (Note 2)	ON	$V_{C(ON)}$	$V_{IN}=14V$	2.0		V
	OFF	$V_{C(OFF)}$	$V_{IN}=14V$		0.8	V
Current for Control	ON	$I_{C(ON)}$	$V_C=2.7V, V_{IN}=14V$		20	μA
	OFF	$I_{C(OFF)}$	$V_C=0.4V, V_{IN}=14V$		-0.4	mA
Quiescent Current	I_Q	$I_{OUT}=0A, V_{IN}=14V$			10	mA

■ ELECTRICAL CHARACTERISTICS(Cont.)

For R15LD20(15V)

PARAMETER	SYMBOL	TEST CONDITIONS	MIN	TYP	MAX	UNIT
Output Voltage	V_{OUT}	$V_{IN} = 17V, I_{OUT} = 1A$	14.55	15.0	15.45	V
Line Regulation	ΔV_{OUT}	$V_{IN} = 16 \sim 20V, I_{OUT} = 5mA$		0.5	2.5	%
Load Regulation	ΔV_{OUT}	$V_{IN} = 17V, I_{OUT} = 5mA \sim 2.0A$		0.1	2.0	%
Temperature Coefficient of Output Voltage	$T_C V_O$	$T_J = 0 \sim 125^\circ C, I_{OUT} = 5mA$		± 0.02		%/ $^\circ C$
Ripple Rejection	RR	Refer to Fig.2	45	55		dB
Dropout Voltage	V_D	(Note 1), $I_{OUT} = 2A$			0.5	V
Voltage for Control (Note 2)	ON	$V_{C(ON)}$	$V_{IN} = 17V$	2.0		V
	OFF	$V_{C(OFF)}$	$V_{IN} = 17V$		0.8	V
Current for Control	ON	$I_{C(ON)}$	$V_C = 2.7V, V_{IN} = 17V$		20	μA
	OFF	$I_{C(OFF)}$	$V_C = 0.4V, V_{IN} = 17V$		-0.4	mA
Quiescent Current	I_Q	$I_{OUT} = 0A, V_{IN} = 17V$			10	mA

Notes: 1. Input voltage shall be the value when output voltage is 95% in comparison with the initial value.

2. In case of opening control terminal(pin 5 of TO-220B, pin 4 of TO-220F-4), output voltage turns on.

TEST CIRCUITS

Note : ○: TO-220F-4, (): TO-220B

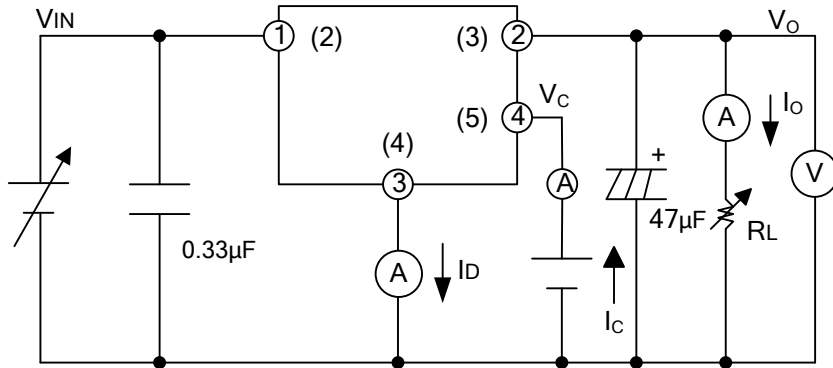
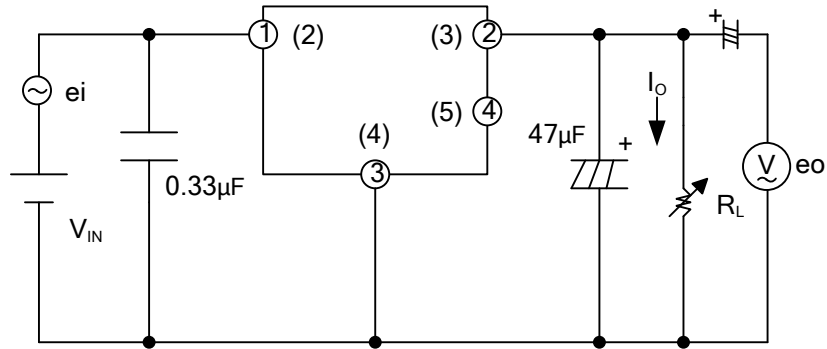

Fig.1



$V_{IN}=5\text{V}$ (R33LD20)	$V_{IN}=11\text{V}$ (R09LD20)	$f=120\text{Hz}$
5.5V(R35LD20)	12V(R10LD20)	$e_i=0.5\text{Vrms}$
7V(R05LD20)	14V(R12LD20)	$I_o=0.5\text{A}$
8V(R06LD20)	17V(R15LD20)	$RR=20\log(e_i/e_o)$
10V(R08LD20)		

Fig.2 For Ripple Rejection

TYPICAL APPLICATION

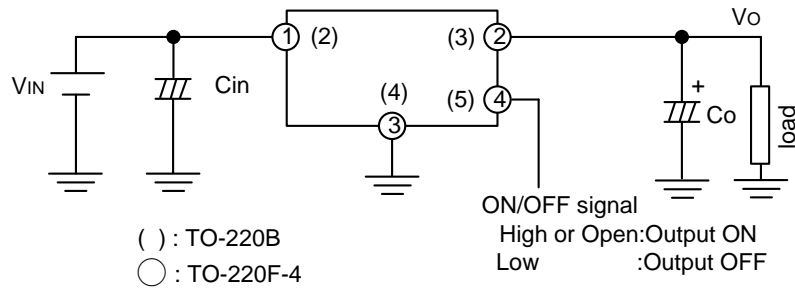

(): TO-220B
○ : TO-220F-4

ON/OFF signal
High or Open: Output ON
Low : Output OFF

TYPICAL CHARACTERISTICS

Fig.3 Power Dissipation vs. Ambient Temperature

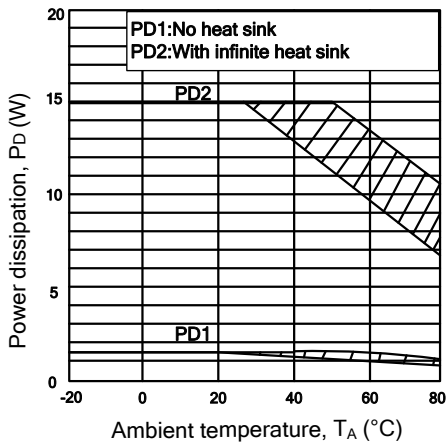

Note: Oblique line portion: Overheat protection may operate in this area.

Fig.4 Overcurrent Protection Characteristics(Typical Value) (R33LD20)

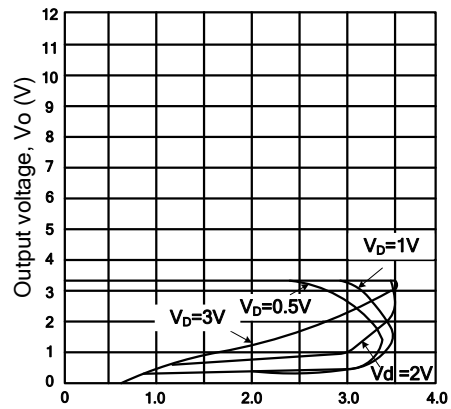

Fig.5 Overcurrent Protection Characteristics (Typical Value)(R05LD20)

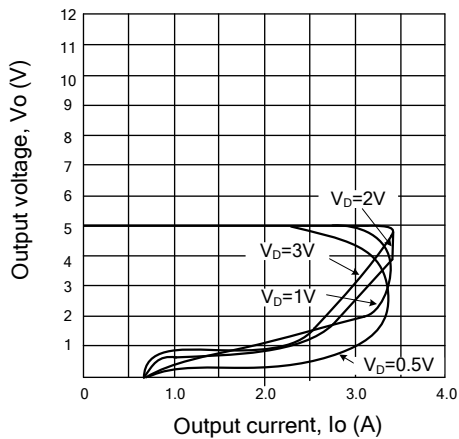

Fig.6 Overcurrent Protection Characteristics (Typical Value)(R09LD20)

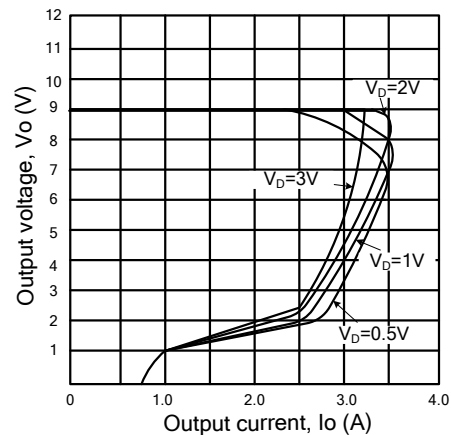

Fig.7 Overcurrent Protection Characteristics (Typical Value)(R12LD20)

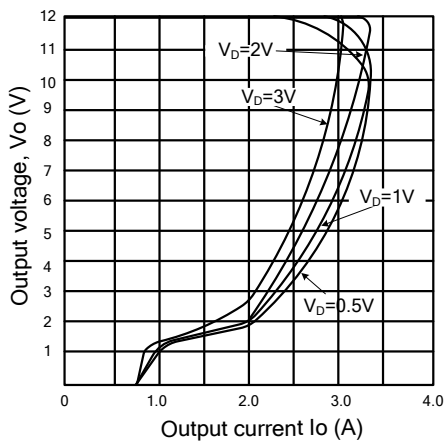
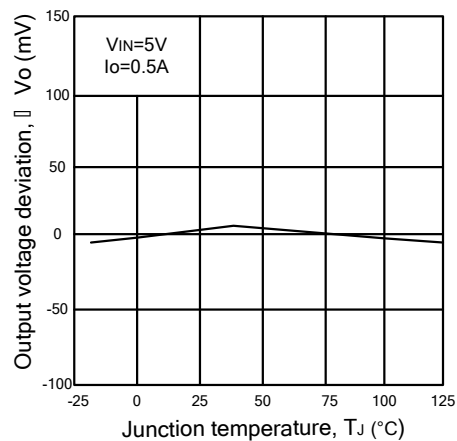

Fig.8 Output Voltage Deviation vs .Junction Temperature (R03LD20)



■ TYPICAL CHARACTERISTICS (Cont.)

Fig.9 Output Voltage Deviation vs .Junction Temperature (R05LD20)

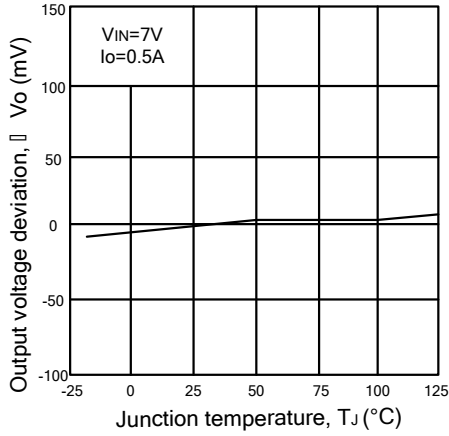

Fig.10 Output Voltage Deviation vs .Junction Temperature (R09LD20)

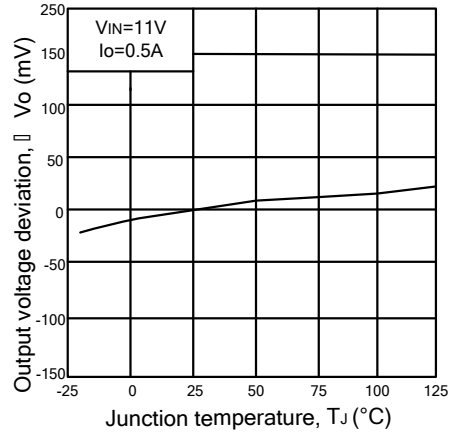

Fig.11 Output Voltage Deviation vs .Junction Temperature (R12LD20)

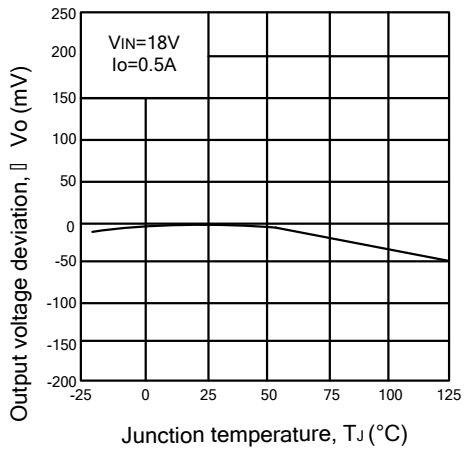

Fig.12 Output Voltage vs .Input Voltage (R33LD20)

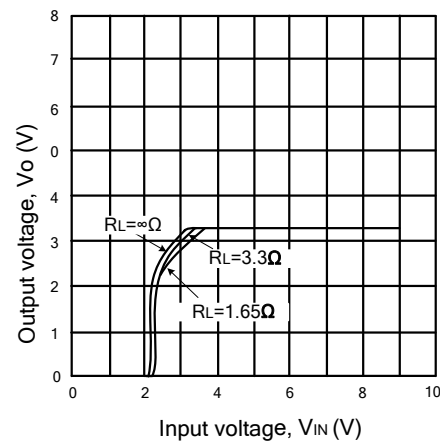

Fig.13 Output Voltage vs .Input Voltage (R05LD20)

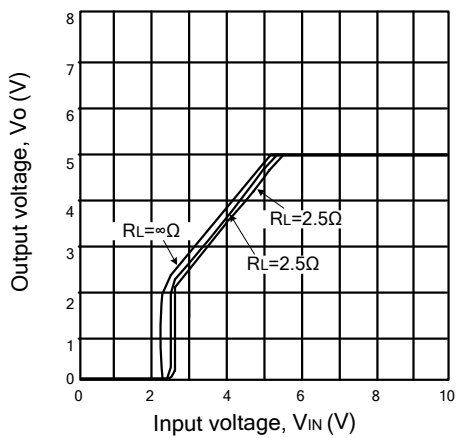
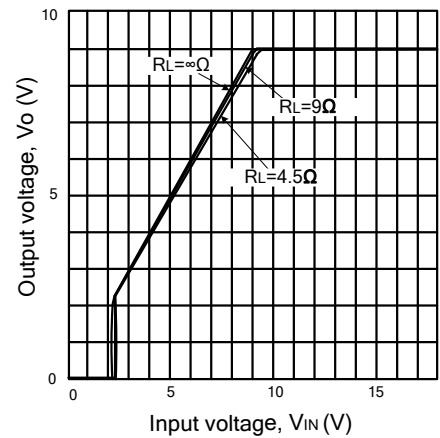

Fig.14 Output Voltage vs .Input Voltage (R09LD20)



■ TYPICAL CHARACTERISTICS (Cont.)

Fig.15 Output Voltage vs .Input Voltage (R12LD20)

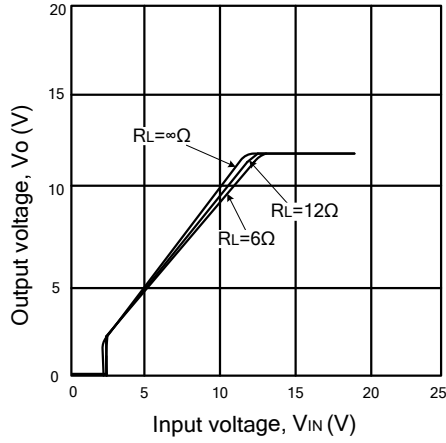

Fig.16 Circuit Operating Current vs .Input Voltage (R33LD20)

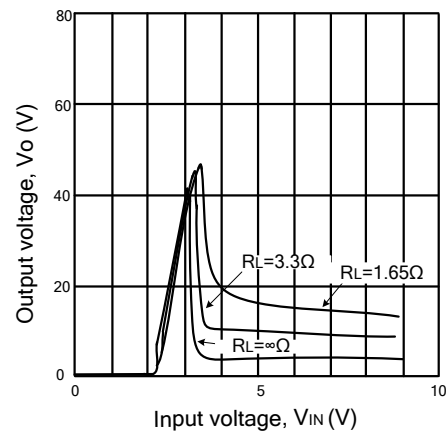

Fig.17 Circuit Operating Current vs .Input Voltage (R05LD20)

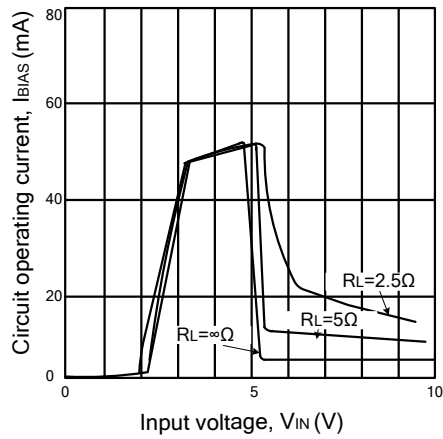

Fig.18 Circuit Operating Current vs .Input Voltage (R09LD20)

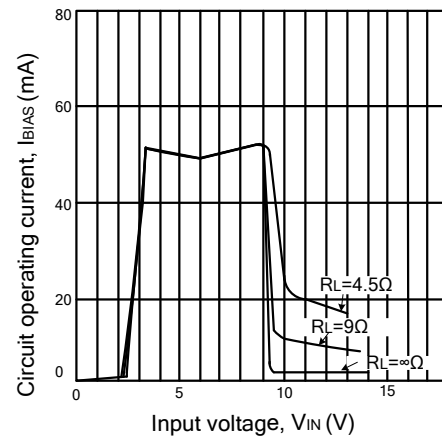

Fig.19 Circuit Operating Current vs .Input Voltage (R12LD20)

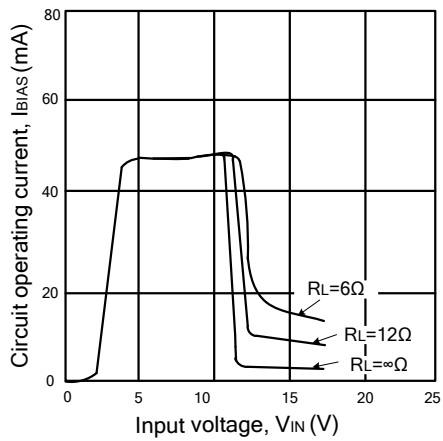
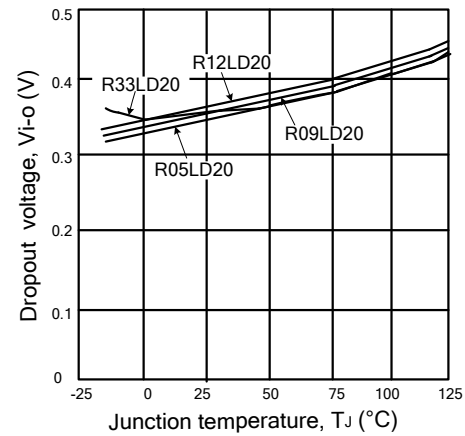

Fig.20 Dropout Voltage vs .Junction Temperature



■ TYPICAL CHARACTERISTICS (Cont.)

Fig.21 Quiescent Current vs. Junction Temperature

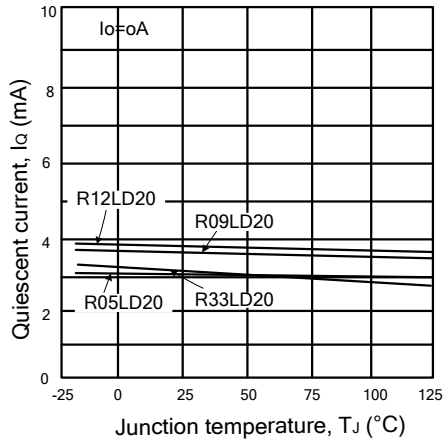
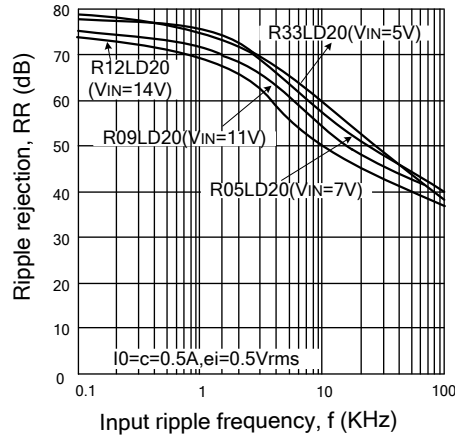

Fig.22 Ripple Rejection vs. Input Ripple Frequency



UTC assumes no responsibility for equipment failures that result from using products at values that exceed, even momentarily, rated values (such as maximum ratings, operating condition ranges, or other parameters) listed in products specifications of any and all UTC products described or contained herein. UTC products are not designed for use in life support appliances, devices or systems where malfunction of these products can be reasonably expected to result in personal injury. Reproduction in whole or in part is prohibited without the prior written consent of the copyright owner. UTC reserves the right to make changes to information published in this document, including without limitation specifications and product descriptions, at any time and without notice. This document supersedes and replaces all information supplied prior to the publication hereof.