



## 88NXX

CMOS IC

### BUILT-IN DELAY CIRCUIT HIGH-PRECISION VOLTAGE DETECTOR

#### DESCRIPTION

The UTC **88NXX** is a high-precision voltage detector developed basing on CMOS technology. The detection voltage is fixed internally. A time delayed reset can be accomplished with an external capacitor. N-ch open-drain output form is available.

The UTC **88NXX** is generally used for power supply monitor of portable equipment such as notebook PCs, digital still cameras, PDAs, and mobile phones, constant voltage power monitor of cameras, video equipment and communication equipment, and power monitor or reset of CPUs and microcomputers.

#### FEATURES

- \* ±2.0 % Accuracy Detection Voltage
- \* Hysteresis Characteristics: 5% TYP
- \* Detection Voltage varies from 2.0V to 4.5V with 0.1V step
- \* Open-Drain **RESET** Active Low Output

#### ORDERING INFORMATION

Ordering Number		Package	Packing
Lead Free	Halogen Free		
88NXXL-AD4-R	88NXXG-AD4-R	SOT-143	Tape Reel
88NXXL-AE2-R	88NXXG-AE2-R	SOT-23-3	Tape Reel
88NXXL-AE5-R	88NXXG-AE5-R	SOT-23-5	Tape Reel
88NXXL-AF5-R	88NXXG-AF5-R	SOT-25	Tape Reel

Note: XX: Output Voltage, refer to Marking Information.

<p>88NXXG-AD4-R</p> <p>(1) Packing Type (2) Package Type (3) Green Package (4) Output Voltage Code</p>	<p>(1) R: Tape Reel (2) AD4: SOT-143, AE2: SOT-23-3, AE5: SOT-23-5, AF5: SOT-25 (3) G: Halogen Free and Lead Free, L: Lead Free (4) XX: Refer to Marking Information</p>
--	--

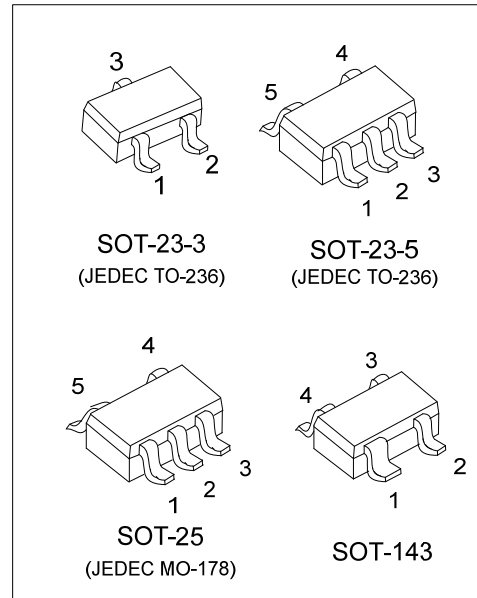

## MARKING INFORMATION

PACKAGE	VOLTAGE CODE		MARKING
SOT-143			<p>L: Lead Free G: Halogen Free Voltage Code</p>
SOT-23-3	20:2.0V 21:2.1V 22:2.2V 23:2.3V 24:2.4V 25:2.5V 26:2.6V 27:2.7V 28:2.8V 29:2.9V 30:3.0V 31:3.1V 32:3.2V	33:3.3V 34:3.4V 35:3.5V 36:3.6V 37:3.7V 38:3.8V 39:3.9V 40:4.0V 41:4.1V 42:4.2V 43:4.3V 44:4.4V 45:4.5V	<p>L: Lead Free G: Halogen Free Voltage Code</p>
SOT-23-5 SOT-25			<p>L: Lead Free G: Halogen Free Voltage Code</p>

## PIN CONFIGURATION

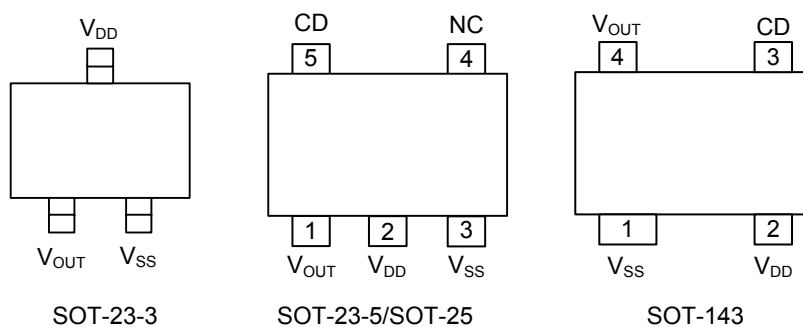

## PIN DESCRIPTION

PIN NO			PIN NAME	DESCRIPTION
SOT-143	SOT-23-3	SOT-23-5 SOT-25		
1	2	3	V <sub>SS</sub>	GND Pin
2	3	2	V <sub>DD</sub>	Voltage Input Pin
3	-	5	CD	Connection Pin For Delay Capacitor
4	1	1	V <sub>OUT</sub>	Voltage Detection Output Pin
-	-	4	NC	No Connection (Note)

Note: The NC pin is electrically open and can be connected to V<sub>DD</sub> or V<sub>SS</sub>.

■ BLOCK DIAGRAM

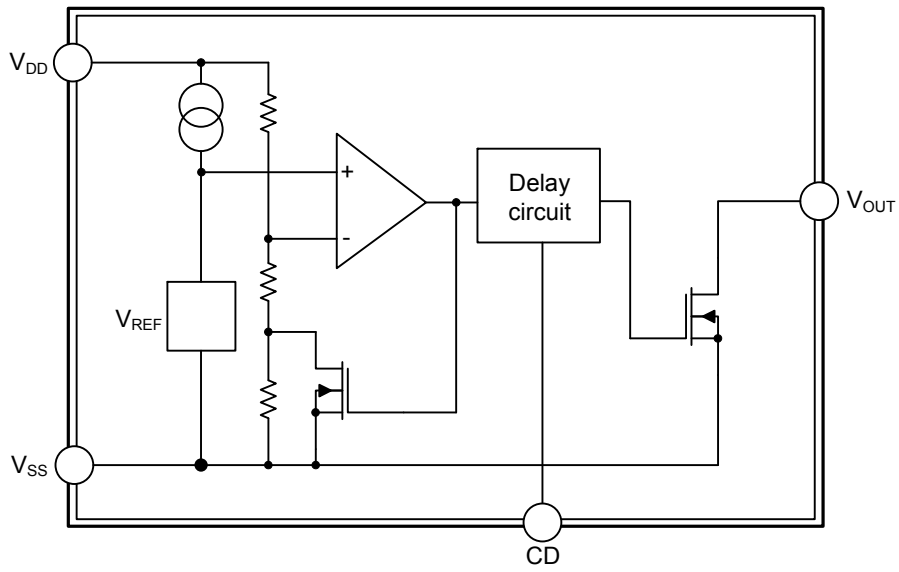

■ ABSOLUTE MAXIMUM RATING (T<sub>A</sub>=25°C, unless otherwise specified)

PARAMETER		SYMBOL	RATINGS	UNIT
Power Supply Voltage		V <sub>DD</sub> - V <sub>SS</sub>	12	V
CD pin Input Voltage		V <sub>CD</sub>	V <sub>SS</sub> -0.3 ~ V <sub>DD</sub> +0.3	V
Output Voltage		V <sub>OUT</sub>	V <sub>SS</sub> -0.3 ~ V <sub>SS</sub> +12	V
Output Current		I <sub>OUT</sub>	50	mA
Power Dissipation	SOT-143	P <sub>D</sub>	150	mW
	SOT-23-3		250	mW
	SOT-23-5			
	SOT-25			
Operating Temperature		T <sub>OPR</sub>	-40 ~ +85	°C
Storage Temperature		T <sub>STG</sub>	-40 ~ +125	°C

Note: Absolute maximum ratings are those values beyond which the device could be permanently damaged. Absolute maximum ratings are stress ratings only and functional device operation is not implied.

■ ELECTRICAL CHARACTERISTICS (T<sub>A</sub>=25°C unless otherwise specified)

**Detection Voltage (2.0V ~ 2.5V)**

PARAMETER	SYMBOL	TEST CIRCUIT	TEST CONDITIONS	MIN	TYP	MAX	UNIT
Detection Voltage (Note 1)	-V <sub>DET</sub>	1		-V <sub>DET(S)</sub> ×0.98	-V <sub>DET(S)</sub>	-V <sub>DET(S)</sub> ×1.02	V
Hysteresis Width	V <sub>HYS</sub>	1		-V <sub>DET</sub> ×0.02	-V <sub>DET</sub> ×0.05	-V <sub>DET</sub> ×0.08	V
Current Consumption	I <sub>SS</sub>	2	V <sub>DD</sub> =3.5V			5	μA
Operating Voltage	V <sub>DD</sub>	1		0.95		10	V
Output Current	I <sub>OUT</sub>	3	Output transistor Nch, V <sub>DS</sub> =0.5V, V <sub>DD</sub> =1.2V	0.3	1.36		mA
Leakage Current	I <sub>LEAK</sub>	3	Output transistor Nch, V <sub>DS</sub> =10V, V <sub>DD</sub> =10V			0.1	μA
Detection Voltage Temperature Coefficient (Note 2)	$\frac{\Delta -V_{DET}}{\Delta T_A} \times -V_{DET}$	1	T <sub>A</sub> =-40°C ~ +85°C		±350		ppm/°C
Delay Time	t <sub>D</sub>	4	V <sub>DD</sub> =3.5V, C <sub>D</sub> =4.7 nF	20		42	ms

**Detection Voltage (2.6V ~ 3.9V)**

PARAMETER	SYMBOL	TEST CIRCUIT	TEST CONDITIONS	MIN	TYP	MAX	UNIT
Detection Voltage (Note 1)	-V <sub>DET</sub>	1		-V <sub>DET(S)</sub> ×0.98	-V <sub>DET(S)</sub>	-V <sub>DET(S)</sub> ×1.02	V
Hysteresis Width	V <sub>HYS</sub>	1		-V <sub>DET</sub> ×0.02	-V <sub>DET</sub> ×0.05	-V <sub>DET</sub> ×0.08	V
Current Consumption	I <sub>SS</sub>	2	V <sub>DD</sub> =4.5V			5	μA
Operating Voltage	V <sub>DD</sub>	1		0.95		10	V
Output Current	I <sub>OUT</sub>	3	Output transistor Nch, V <sub>DS</sub> =0.5V, V <sub>DD</sub> =2.4V	2.88	4.98		mA
Leakage Current	I <sub>LEAK</sub>	3	Output transistor Nch, V <sub>DS</sub> =10V, V <sub>DD</sub> =10V			0.1	μA
Detection Voltage Temperature Coefficient (Note 2)	$\frac{\Delta -V_{DET}}{\Delta T_A} \times -V_{DET}$	1	T <sub>A</sub> =-40°C ~ +85°C		±350		ppm/°C
Delay Time	t <sub>D</sub>	4	V <sub>DD</sub> =4.5V, C <sub>D</sub> =4.7nF	12		34	ms
			V <sub>DD</sub> =4.5V, C <sub>D</sub> =0nF			0.5	ms

■ ELECTRICAL CHARACTERISTICS (Cont.)

**Detection voltage (4.0V ~ 4.5V)**

PARAMETER	SYMBOL	TEST CIRCUIT	TEST CONDITIONS	MIN	TYP	MAX	UNIT
Detection Voltage (Note 1)	$-V_{DET}$	1		$-V_{DET(S)} \times 0.98$	$-V_{DET(S)}$	$-V_{DET(S)} \times 1.02$	V
Hysteresis Width	$V_{HYS}$	1		$-V_{DET} \times 0.02$	$-V_{DET} \times 0.05$	$-V_{DET} \times 0.08$	V
Current Consumption	$I_{SS}$	2	$V_{DD}=5.5V$			5	$\mu A$
Operating Voltage	$V_{DD}$	1		0.95		10	V
Output Current	$I_{OUT}$	3	Output transistor Nch, $V_{DS}=0.5V$ , $V_{DD}=2.4V$	2.88	4.98		mA
Leakage Current	$I_{LEAK}$	3	Output transistor Nch, $V_{DS}=10V$ , $V_{DD}=10V$			0.1	$\mu A$
Detection Voltage Temperature Coefficient (Note 2)	$\frac{\Delta -V_{DET}}{\Delta T_A \times -V_{DET}}$	1	$T_A=-40^\circ C \sim +85^\circ C$		$\pm 350$		ppm/ $^\circ C$
Delay Time	$t_D$	4	$V_{DD}=4.5V$ , $C_D=4.7 nF$	12		34	ms

Notes: 1.  $-V_{DET}$ : Actual detection voltage

$-V_{DET(S)}$ : Specified detection voltage.

2. The temperature change ratio in the detection voltage [mV/ $^\circ C$ ] is calculated by using the following equation:

$$\frac{\Delta -V_{DET}}{\Delta T_A} [mV/^\circ C]^{(1)} = -V_{DET} (Typ.) [V]^{(2)} \times \frac{\Delta -V_{DET}}{\Delta T_A \times -V_{DET}} [ppm / ^\circ C]^{(3)} \div 1000$$

(1). Temperature change ratio of the detection voltage.

(2) Specified detection voltage.

(3) Detection voltage temperature coefficient

## ■ TEST CIRCUITS

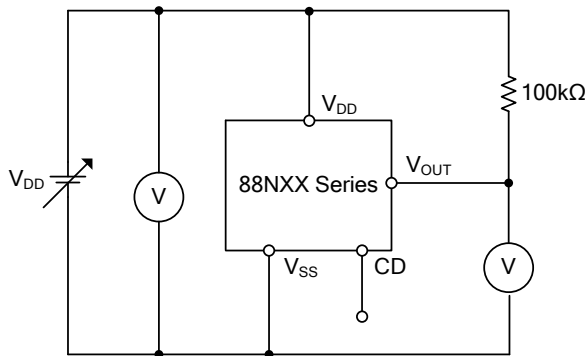

Fig.1

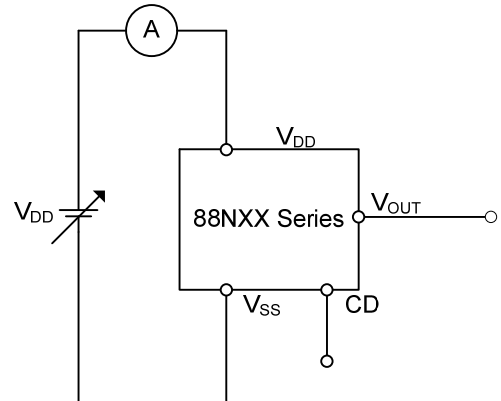

Fig.2

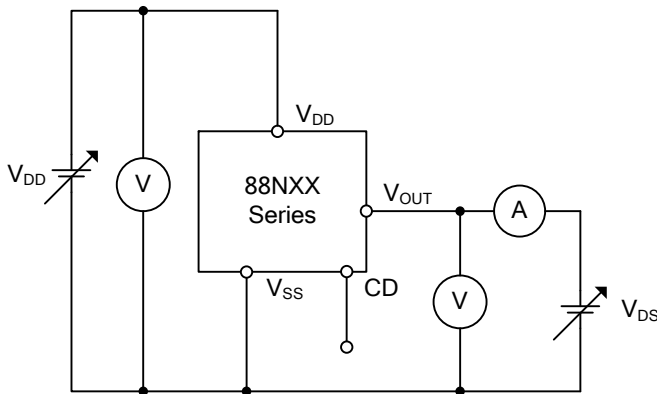

Fig.3

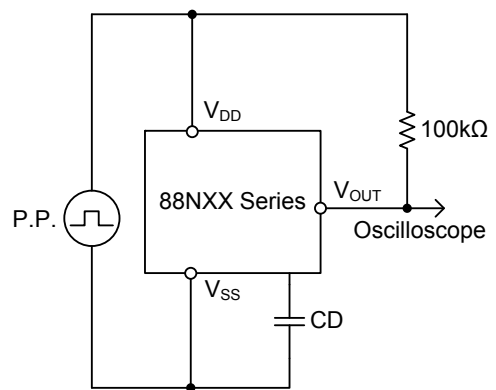

Fig.4

UTC assumes no responsibility for equipment failures that result from using products at values that exceed, even momentarily, rated values (such as maximum ratings, operating condition ranges, or other parameters) listed in products specifications of any and all UTC products described or contained herein. UTC products are not designed for use in life support appliances, devices or systems where malfunction of these products can be reasonably expected to result in personal injury. Reproduction in whole or in part is prohibited without the prior written consent of the copyright owner. UTC reserves the right to make changes to information published in this document, including without limitation specifications and product descriptions, at any time and without notice. This document supersedes and replaces all information supplied prior to the publication hereof.