



## U9751B

### LINEAR INTEGRATED CIRCUIT

## DOUBLE CHANNELS PWM CONTROLLER

### DESCRIPTION

The UTC **U9751B** consists of two PWM control circuits. Two PWM controllers is independent each other. It is low cost in many applications.

### FEATURES

- \* Switch frequency: 400KHz
- \*  $I_{SINK} = 400mA$
- \* Wide work voltage
- \* Programmable dead-time control
- \* UVLO protection
- \* SCP protection
- \* Lower static supply current

### APPLICATION

\* DC/DC converters for video cameras, backlight inverter and notebook computers etc.

### ORDER INFORMATION

Order Number		Package	Packing
Normal	Lead Free Plating		
U9751B-D16-T	U9751BL-D16-T	DIP-16	Tube
U9751B-S16-R	U9751BL-S16-R	SOP-16	Tape Reel
U9751B-S16-T	U9751BL-S16-T	SOP-16	Tube
U9751B-R16-R	U9751BL-R16-R	SSOP-16	Tape Reel
U9751B-R16-T	U9751BL-R16-T	SSOP-16	Tube

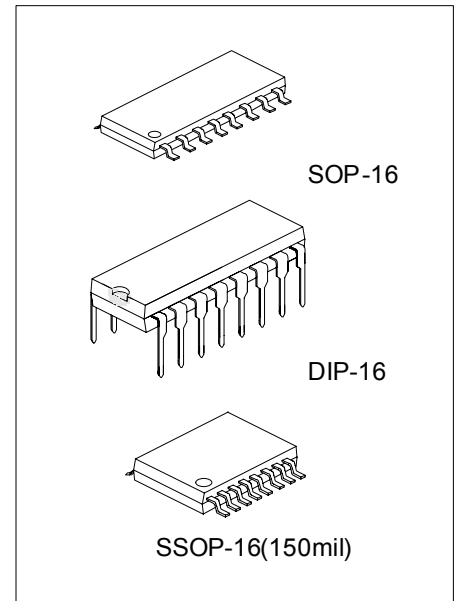

\*Pb-free plating product number: U9751BL

<p>U9751BL-D16-R</p> <p>(1)Packing Type (2)Package Type (3)Lead Plating</p>	<p>(1) R: Tape Reel, T: Tube (2) D16: DIP-16, S16: SOP-16, R16: SSOP-16 (3) L: Lead Free Plating, Blank: Pb/Sn</p>
---	--

### ■ PIN CONFIGURATION

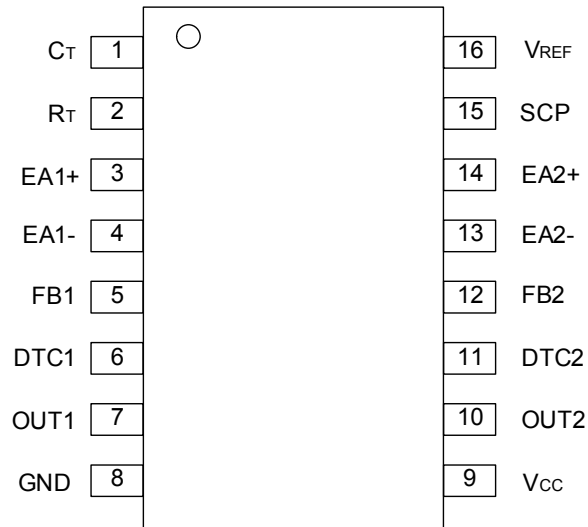

### ■ PIN DESCRIPTION

NO.	NAME	DESCRIPTION
1	C <sub>T</sub>	Capacitor connected to the pin controlling Oscillator frequency
2	R <sub>T</sub>	Resistor connected to the pin controlling Oscillator frequency
3	EA1+	Error Amplifier 1 positive Input
4	EA1-	Error Amplifier 1 Inverting Input
5	FB1	Error Amplifier 1 Output, used for feedback output 1
6	DTC1	Dead-Time Comparator Output 1
7	OUT1	Output 1
8	GND	Ground
9	V <sub>CC</sub>	Power Supply
10	OUT2	Output 2
11	DTC2	Dead-Time Comparator Output 2
12	FB2	Error Amplifier 2 Output, used for feedback output 2
13	EA2-	Error Amplifier 2 Inverting Input
14	EA2+	Error Amplifier 2 positive Input
15	SCP	Short Circuit Protection Input
16	V <sub>REF</sub>	Internal 2.5V Reference Voltage

## ■ BLOCK DIAGRAM

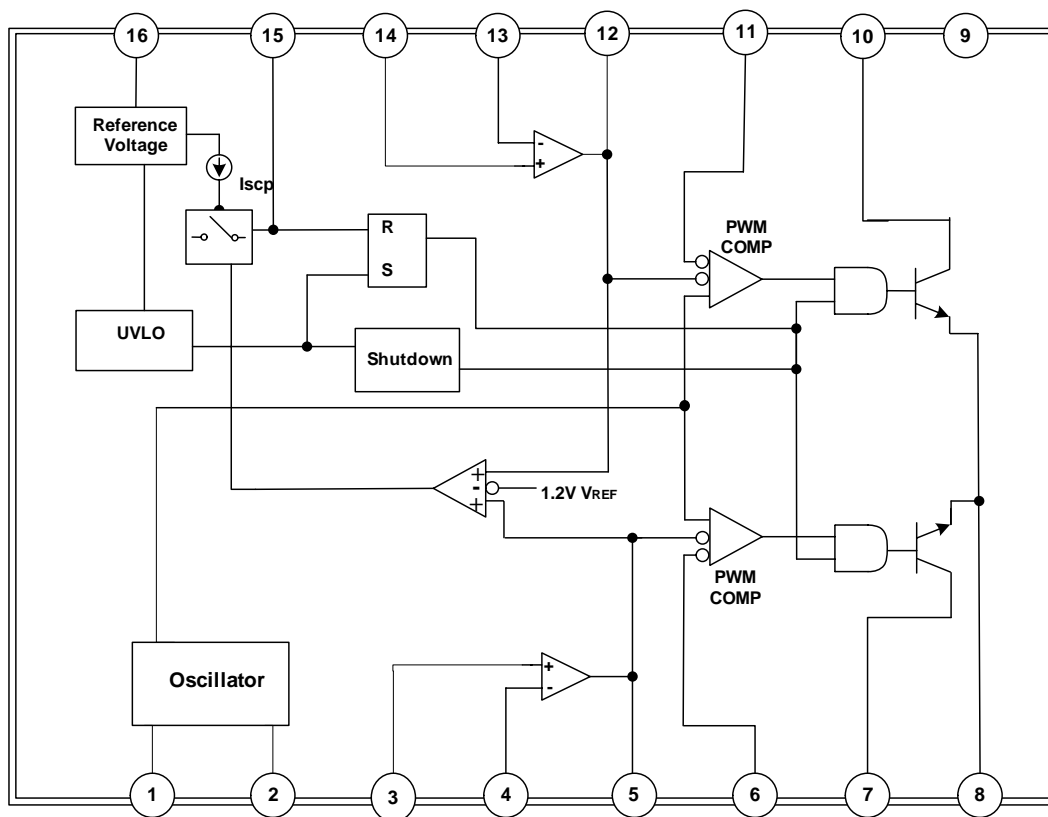

## ■ ABSOLUTE MAXIMUM RATINGS

PARAMETER	SYMBOL	RATINGS	UNIT
Supply Voltage	$V_{CC}$	+38	V
Differential Input Voltage	$V_{I(DIFF)}$	+20	V
Output Voltage	$V_{OUT}$	+38	V
Output Current	$I_{OUT}$	+450	mA
Maximum Junction Temperature	$T_J$	+150	
Operating Temperature	$T_{OPR}$	-20 ~ +85	
Storage Temperature	$T_{STG}$	-55 ~ +150	

Note: Absolute maximum ratings are those values beyond which the device could be permanently damaged.

Absolute maximum ratings are stress ratings only and functional device operation is not implied.

## ■ DC ELECTRONIC CHARACTERISTICS

$V_{CC}=6V$ ,  $f=200kHz$  (unless otherwise specified)

PARAMETER	SYMBOL	TEST CONDITIONS	MIN	TYP	MAX	UNIT
<b>Reference section</b>						
Internal Reference Voltage	$V_{REF}$	$I_{OUT} = 1mA$	2.40	2.46	2.53	V
$V_{REF}$ Regulation with $V_{CC}$	$V_{REF}$	$V_{CC} = 3.6V \sim 40V$		3.5		mV
$V_{REF}$ Regulation with $I_{O(REF)}$	$V_{REF}$	$I_{OUT} = 0.1mA \text{ to } 1mA$		2		mV
$V_{REF}$ Regulation with Temperature		$T_A = -20 \sim 25$		-0.1%	$\pm 1\%$	
		$T_A = 25 \sim 85$		-0.2%	$\pm 1\%$	
Short-Circuit Output Current	$I_{O(SC)}$	$V_{OUT} = 0$	18	22	30	mA
<b>Undervoltage Lockout Section</b>						
threshold Voltage( $V_{CC}$ )	$V_{THR}$	$I_{O(REF)} = 0.1mA, T_A = 25$	2.5	2.8	3.2	V
<b>Short-Circuit Protection Control Section</b>						
SCP Input Threshold Voltage	$V_{I(THR)}$	$T_A = 25$	1.2	1.3	1.5	V
SCP Comparator Threshold Voltage	$V_{COM(THR)}$			1.26		V
SCP Standby Voltage	$V_{STN-BY}$	No pull-up		110	220	mV
SCP Latched Input voltage	$V_{I(LTH)}$	No pull-up		77	200	mV
Input (Source) Current	$I_{I(SOURCE)}$	$V_{IN} = 0.7V, T_A = 25$	-1.5	-2.0	-2.5	$\mu A$
<b>Oscillator Section</b>						
Frequency	$f$	$C_T = 220pF, R_T = 10K$		400		KHz
Deviation of Frequency	$f$	$C_T = 220pF, R_T = 10K$		10%		
Frequency Regulation with Voltage	$f / V$	$V_{CC} = 3.6V \text{ to } 40V$		1%		
Frequency Regulation with Temperature	$f / T$	$T_A = -20 \sim 25$		-0.4%	$\pm 2\%$	
		$T_A = 25 \sim 85$		-0.2%	$\pm 2\%$	
<b>Dead-time control section</b>						
Latched Input Voltage	$V_{I(LTH)}$	$I_{OUR(DTC)} = 40\mu A$	1.9			V
Input Threshold Voltage at $f=10kHz$	$V_{I(THR)}$	Zero duty cycle	1.75	1.95	2.15	V
		Maximum duty cycle	1.3	1.45	1.7	
Input Bias Current	$I_{I(BIAS)}$			0.2	1	$\mu A$
Latch Mode (Source) Current	$I_{SOURCE}$	$T_A = 25$		-620		$\mu A$
<b>Error-Amplifier Section</b>						
Input Offset Voltage	$V_{I(OFF)}$	$V_{O(FB)} = 1.25V$			$\pm 6$	mV
Common-Mode Input Voltage Range	$V_{I(CM)}$	$V_{CC} = 3.6V \text{ to } 40V$	0.3		1.6	V
Positive Output Voltage Swing	$V_{O(POS)}$		$V_{REF} - 0.2$			V
Negative Output Voltage Swing	$V_{O(NEG)}$				1	V
Input Offset Current	$I_{I(OFF)}$	$V_{O(FB)} = 1.25V$			$\pm 100$	nA

■ DC ELECTRONIC CHARACTERISTICS(Cont.)

PARAMETER	SYMBOL	TEST CONDITIONS	MIN	TYP	MAX	UNIT
Input Bias Current	$I_{I(BIAS)}$	$V_{O(FB)}=1.25V$		160	500	nA
Output Sink Current	$I_{O(SINK)}$	$V_{I(DIFF)}=-0.1V, V_{OUT}=1.25V$	1	4.0		mA
Output Source Current	$I_{O(SOURCE)}$	$V_{I(DIFF)}=0.1V, V_{OUT}=1.25V$	-45	-90		$\mu A$
Common-Mode Rejection Ratio	CMRR		60	80		dB
Open-Loop Voltage Gain	$G_{VO}$	$R_F=200K\Omega$	70	80		dB
Unity-Gain Bandwidth	$GB_W$			1.5		MHz
<b>Output Section</b>						
Output Saturation Voltage	$V_{O(SAT)}$	$I_{OUT}=10mA$		0.7	1	V
Short-Circuit Output Current	$I_{O(SC)}$	$V_{OUT}=6V$		450		mA
Off-State Current	$I_{O(OFF)}$	$V_{OUT}=50V$			10	$\mu A$
<b>PWM Comparator Section</b>						
Input Threshold Voltage at f=10kHz	$V_{I(THR)}$	Zero duty cycle	1.75	1.95	2.15	V
		Maximum duty cycle	1.3	1.45	1.8	
<b>Total Device</b>						
Standby Supply Current	$I_{STN-BY}$	Off-state		1.7		mA
Average Supply Current	$I_{AVE}$	$R_T=10K$		2.0	2.6	mA

### TYPICAL APPLICATION

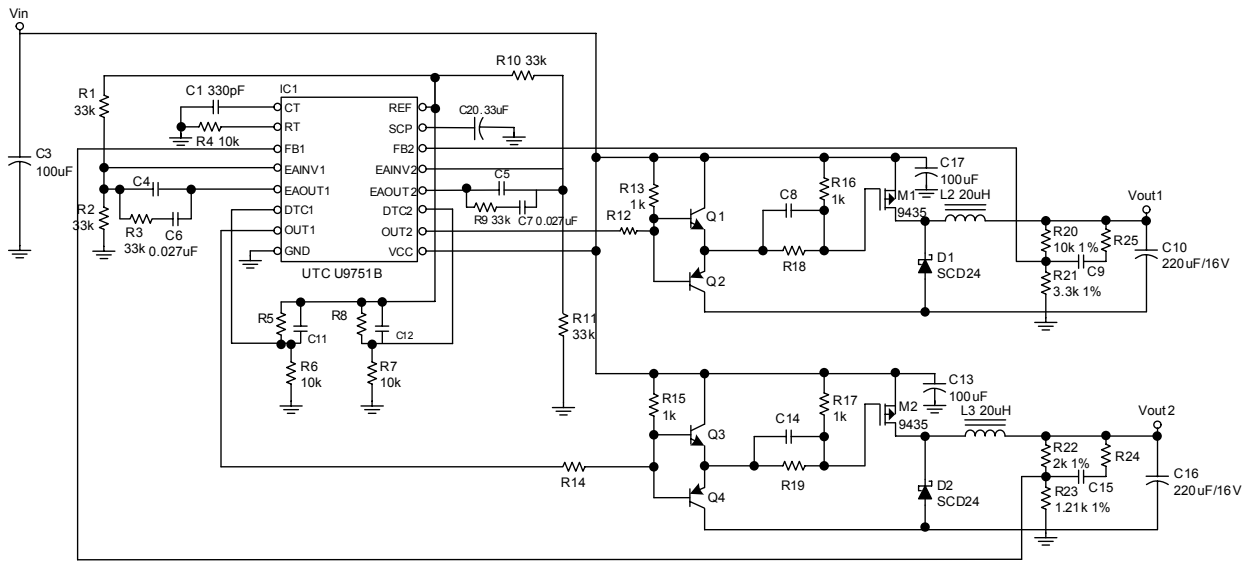

Typical Application

### TIMING WAVEFORM

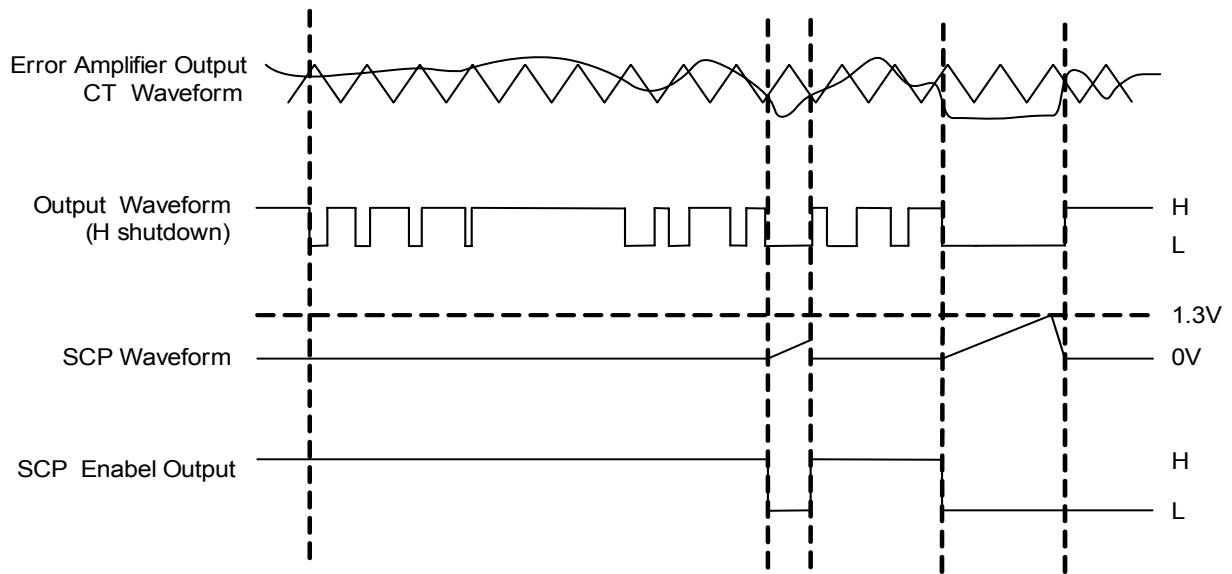

Timing Diagram

UTC assumes no responsibility for equipment failures that result from using products at values that exceed, even momentarily, rated values (such as maximum ratings, operating condition ranges, or other parameters) listed in products specifications of any and all UTC products described or contained herein. UTC products are not designed for use in life support appliances, devices or systems where malfunction of these products can be reasonably expected to result in personal injury. Reproduction in whole or in part is prohibited without the prior written consent of the copyright owner. The information presented in this document does not form part of any quotation or contract, is believed to be accurate and reliable and may be changed without notice.