



TA8227AP

LINEAR INTEGRATED CIRCUIT

LOW FREQUENCY POWER AMPLIFIER

DESCRIPTION

The UTC TA8227AP is an audio power IC with built-in two channels developed for portable radio cassette tape recorder with power ON / OFF switch.

Thermal shut down protection circuit is built in.

FEATURES

- * Wide operating supply voltage: $V_{CC}=5\sim 12V$
- * Low popping noise at power ON
- * Best for supply voltage 9V
- * Output power
 $P_{OUT}=2.5W/CH$ at $V_{CC}=9V, R_L=4\Omega, f=1kHz, THD=10\%$
 $P_{OUT}=3.0W/CH$ at $V_{CC}=9V, R_L=3\Omega, f=1kHz, THD=10\%$
- * Soft Clip
- * Built-in thermal shut-down protection circuit
- * Stand-by switch

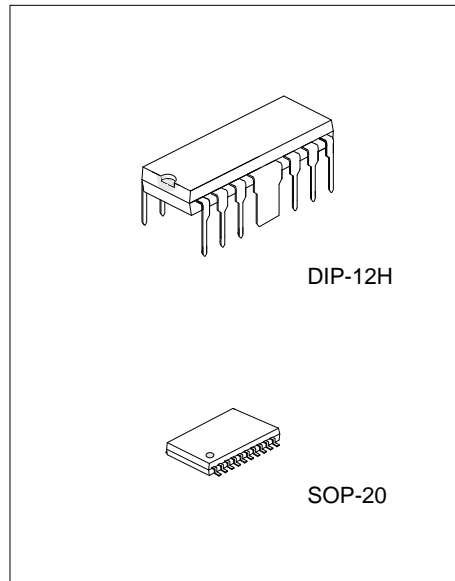

ORDERING INFORMATION

Ordering Number		Package	Packing
Lead Free	Halogen Free		
TA8227APL-D12H-T	TA8227APG-D12H-T	DIP-12H	Tube
TA8227APL-S20-R	TA8227APG-S20-R	SOP-20	Tape Reel

<p>TA8227APG-D12H-T</p> <ul style="list-style-type: none"> (1) Packing Type (2) Package Type (3) Green Package 	<ul style="list-style-type: none"> (1) T: Tube, R: Tape Reel (2) D12H: DIP-12H, S20: SOP-20 (3) G: Halogen Free and Lead Free
---	--

MARKING

DIP-12H	SOP-20
<ul style="list-style-type: none"> Date Code L: Lead Free G: Halogen Free Lot Code 	<ul style="list-style-type: none"> Date Code L: Lead Free G: Halogen Free Lot Code

PIN CONFIGURATION

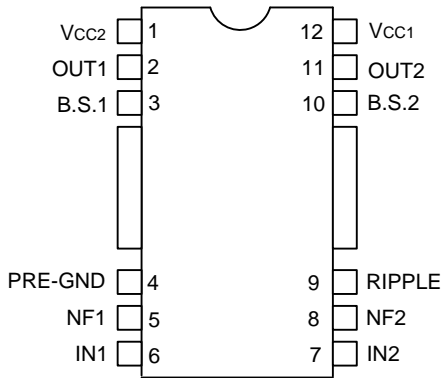

DIP-12H

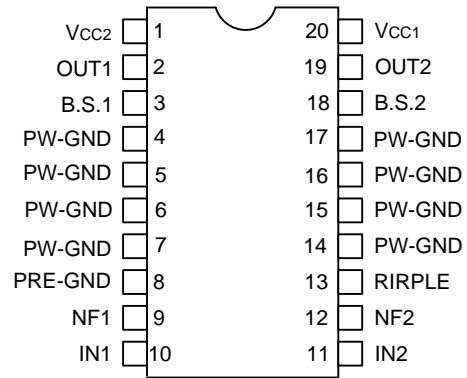

SOP-20

BLOCK DIAGRAM

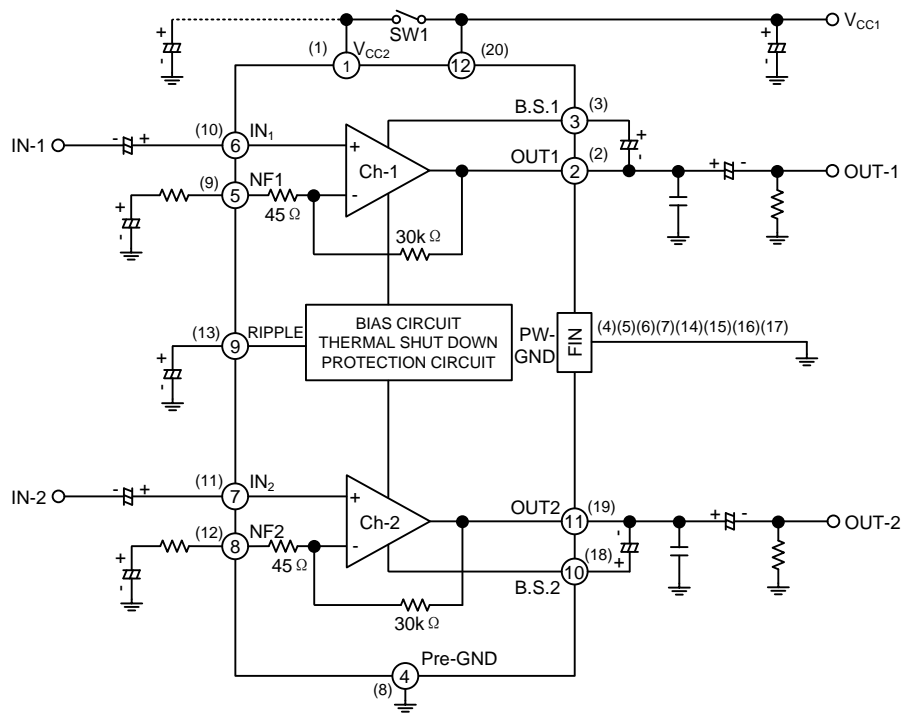

■ ABSOLUTE MAXIMUM RATINGS (T_A=25°C, unless otherwise specified)

PARAMETER	SYMBOL	VALUE	UNIT
Supply Voltage	V _{CC}	20	V
Output Current (peak / CH)	I _{O(PEAK)}	2.5	A
Power Dissipation	P _D	4.0	W
Operating Temperature	T _{OPR}	-25~+75	°C
Storage Temperature	T _{STG}	-55~+150	°C

■ ELECTRICAL CHARACTERISTICS

(T_A=25°C, V_{CC}=9V, R_L=4Ω, R_G=600Ω, f=1kHz, unless otherwise specified)

PARAMETER	SYMBOL	TEST CONDITIONS	MIN	TYP	MAX	UNIT
Quiescent Current	I _{CCQ}	V _{IN} =0		21	45	mA
Output Power	P _{OUT(1)}	THD=10%	2.0	2.5		W
	P _{OUT(2)}	THD=10%, R _L =3Ω		3.0		
Total Harmonic Distortion	THD	P _{OUT} =0.4W/CH		0.2	1.0	%
Voltage Gain	G _{v1}	R _f =120Ω, V _{OUT} =0.775Vrms (0 dBm)	43	45	47	dB
	G _{v2}	R _f =0, V _{OUT} =0.775Vrms (0 dBm)		56.5		
Input Impedance	R _{IN}			30		kΩ
Output Noise Voltage	e _N	R _g =10kΩ, BW=20Hz ~20kHz		0.3	1.0	mVrms
Ripple Rejection Ratio	R.R.	R _g =600Ω, fripple=100Hz		-52		dB
Cross Talk	C.T	R _g =600Ω, V _{OUT} =0.775Vrms (0 dBm)		-50		dB
Input Offset Voltage	V ₆ , V ₇			30	60	mV
Standby Current	1stb	Sw1:OFF		1	50	μA

■ TYP. DC VOLTAGE OF EACH TERMINAL (V_{CC}=9V, T_A=25°C, unless otherwise specified)

TERMINAL NO.	1	2	3	4	5	6	7	8	9	10	11	12
DC VOLTAGE (V)	V _{CC}	4.5	8.7	GND	0.7	0.03	0.03	0.7	5.0	8.7	4.5	V _{CC}

■ APPLICATION INFORMATION AND APPLICATION METHOD

1. Adjustment of voltage gain

The voltage gain G_v is obtained as follows by R₁, R₂ and R_f in Fig.1

$$G_v = 20 \log \frac{R_f + R_1 + R_2}{R_f + R_1}$$

When R_f = 0Ω G_v=56.5 dB (Typ.)

When R_f = 120Ω G_v=45 dB (Typ.)

By increasing R_f, reduction of G_v is possible. However, since the feedback increase is liable to produce oscillation, it is recommended to use this at 40dB or over.

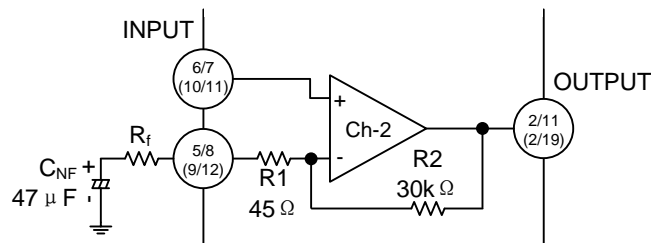

() : For SOP-20 Package

Fig.1

APPLICATION INFORMATION AND APPLICATION METHOD (Cont.)

2. Thermal shut-down circuit

The thermal shut-down circuit is built in for the purpose of preventing the destruction of IC due to the abnormal temperature rise when the heat radiation is insufficient.

The operation temperature is set at radiation Fin temperature 175°C (Typ.)

At this temperature or over the bias is interrupted to prevent the destruction of IC.

3. Input stage

The input circuit of this IC is as shown in fig.2. PNP Tr : Q1 is provided in the input circuit so as to make its usage possible without the input coupling capacitor.

However, at pin 6 and pin 7, max 60mV offset voltage is produced.

Application after checking volume slide noise is recommended.

For cutting the volume slide noise, insert the input capacitor: C_{IN} in series to interrupt the DC component.

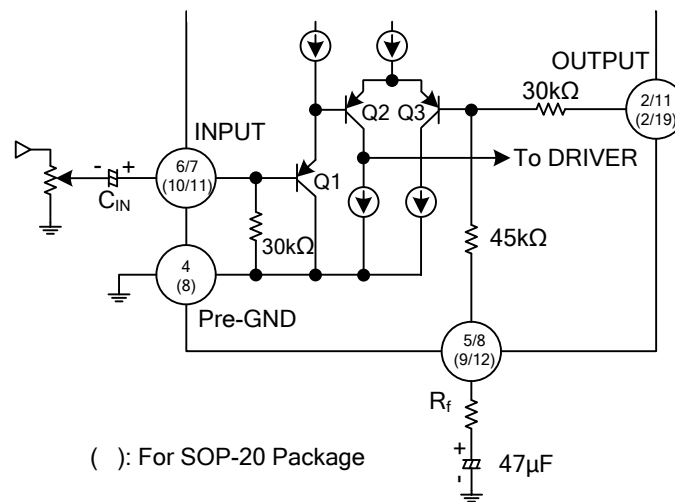

4. Oscillation preventive measures

For oscillation preventive capacitor C6 and C7 between the output terminal and GND, it is recommended to use polyester film capacitor having good characteristics for temperature and for high frequency.

Since the characteristics of the capacitor is liable to be influenced by the temperature, use this capacitor after the temperature test to check the oscillation allowance.

In addition, as the position of the electrolytic capacitor has a remarkable influence on the oscillation, connect C10 to V_{CC} at the nearest possible position from power GND.

At using this application with the voltage gain reduced, oscillation is liable to be produced. Apply the capacitor after checking enough for its capacity, type and mounting position.

5. Power ON / OFF switch

There is power ON / OFF switch at Pin1. However, output power is changed by Pin1 supply voltage when Pin1 supply voltage is not same Pin12 supply voltage, after referring to attached date, select Pin1 supply voltage.

6. Input voltage

When the excessive signal is input, turning-up is produced in the clip waveform. The turning-up point is V_{IN}=300mV_{rms} (Typ.) : V_{CC}=9V, R_L=4Ω, f=1kHz : Enough care must be taken for this phenomenon.

■ TEST CIRCUIT

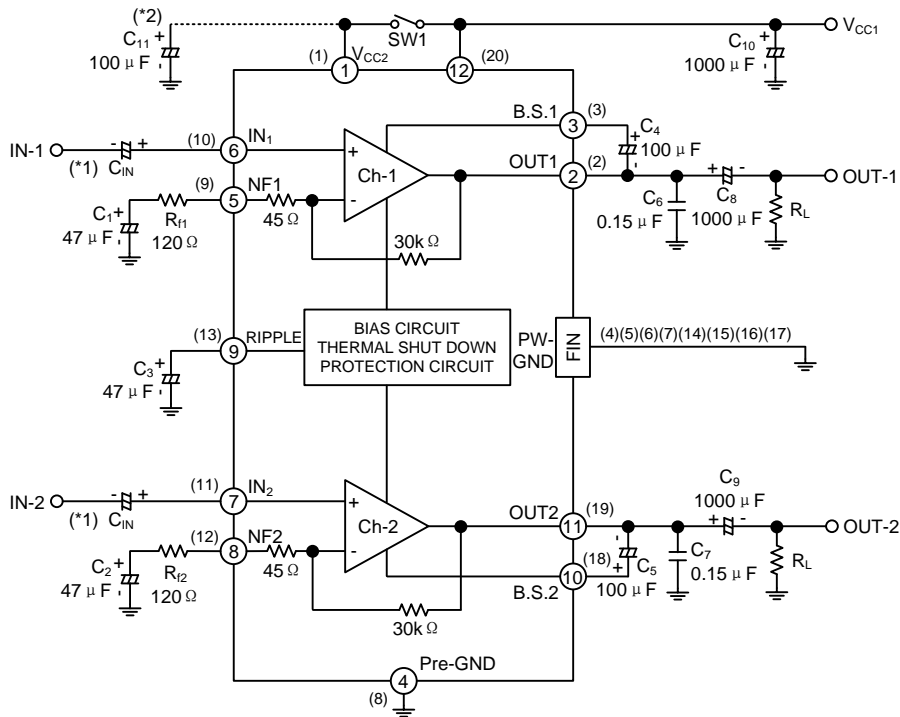

():For SOP-20 Package

- Notes:
1. This IC can be used without coupling capacitor (C_{IN}). If volume slide noise occurred by input offset voltage is undesirable, it needs to use the capacitor (C_{IN}).
 2. The condenser between the pin1 and the GND (C_{11}) is for reducing pop noise when the power ON / OFF switch (SW1) is set to ON / OFF.

TYPICAL CHARACTERISTICS

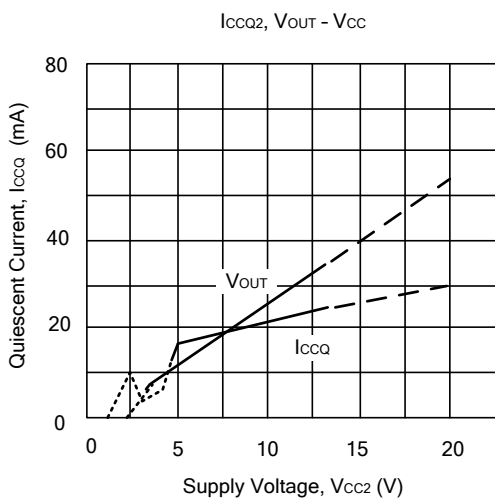
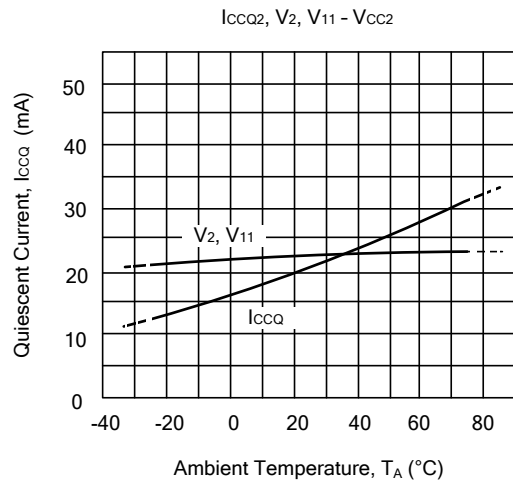
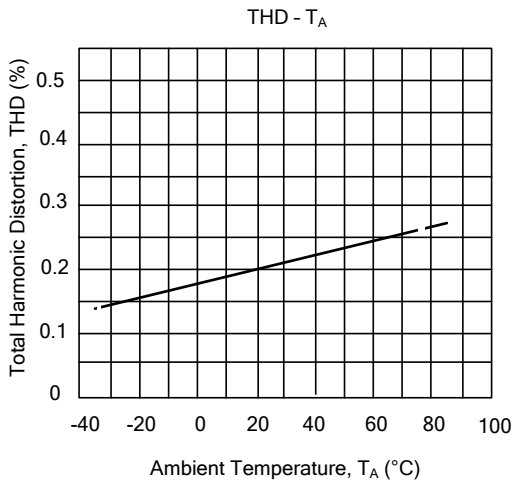
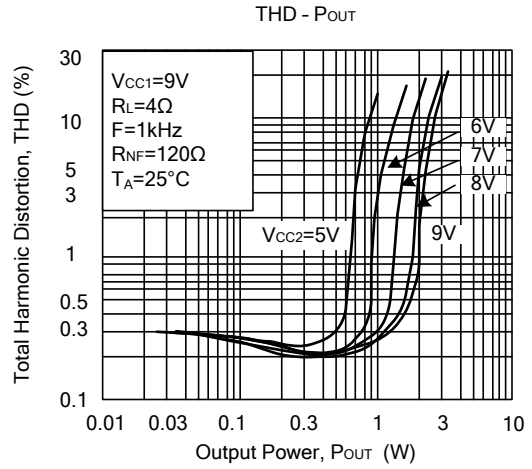
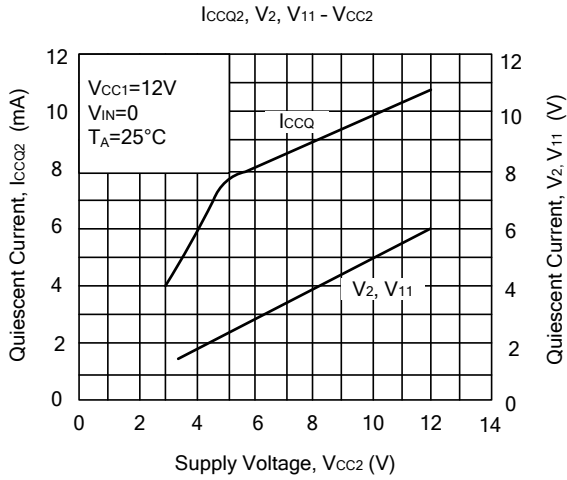

TYPICAL CHARACTERISTICS(Cont.)

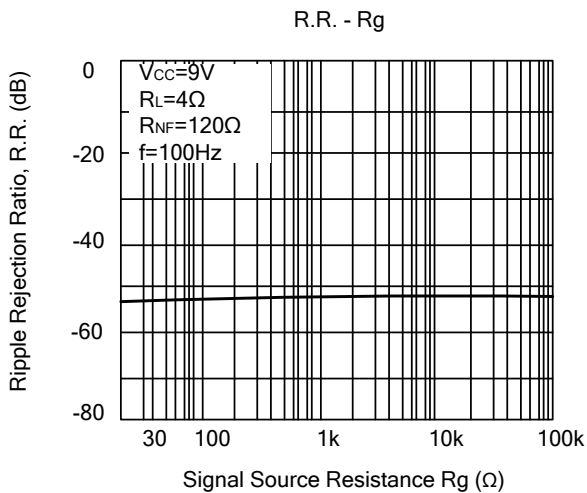
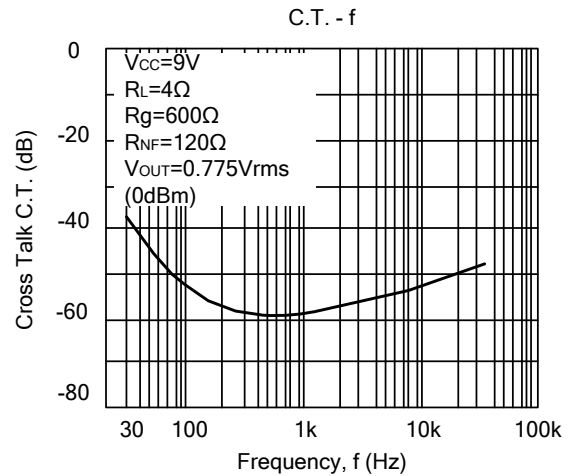
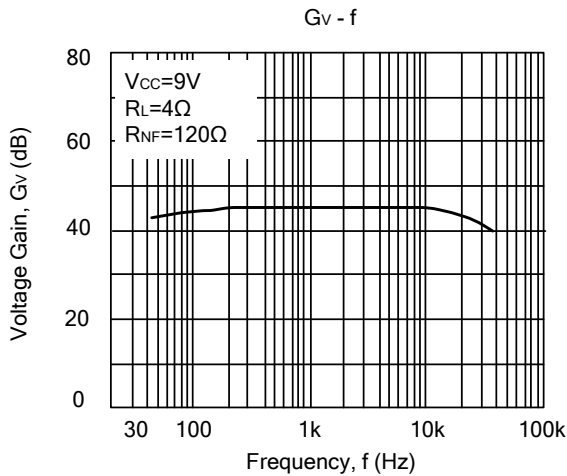
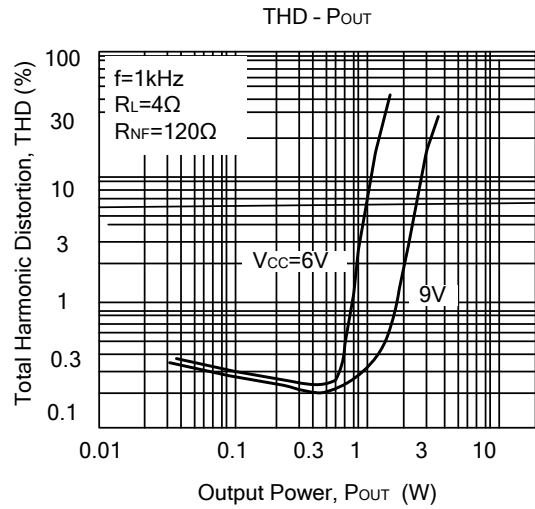
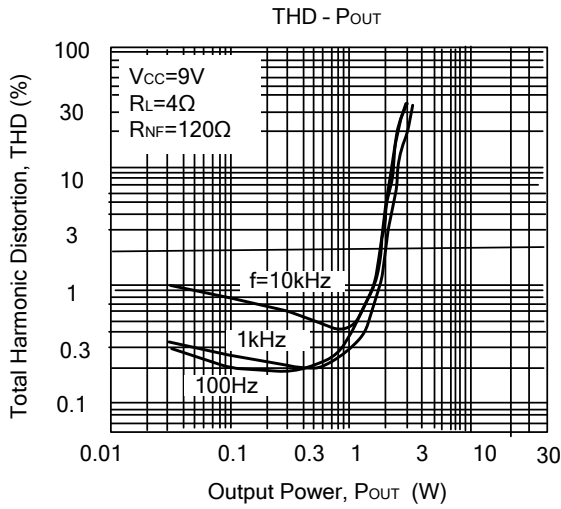

■ TYPICAL CHARACTERISTICS(Cont.)

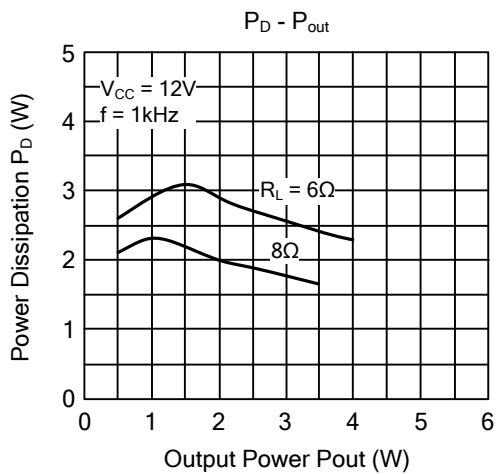
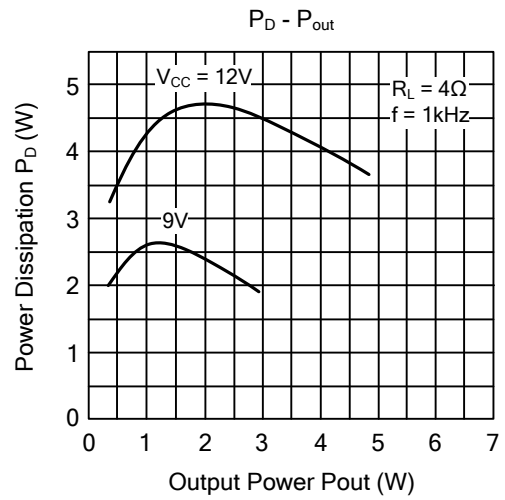
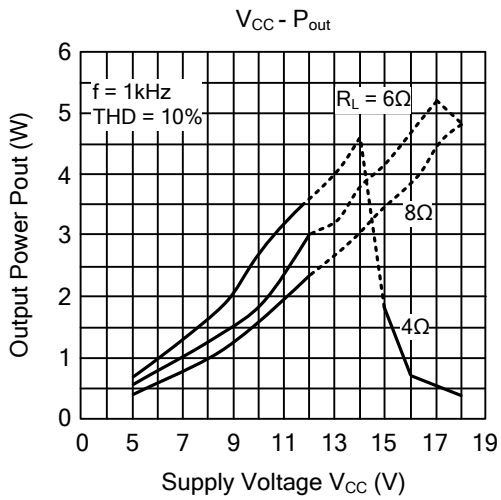
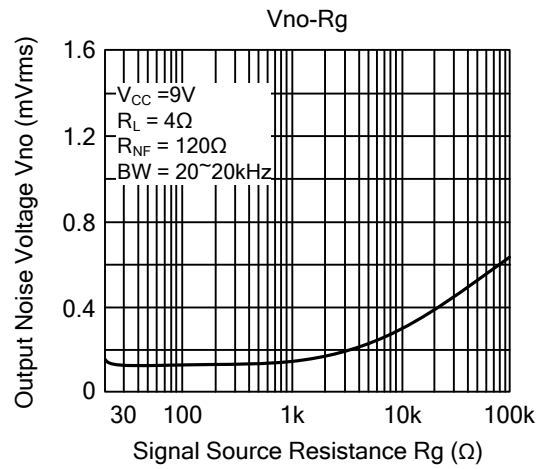
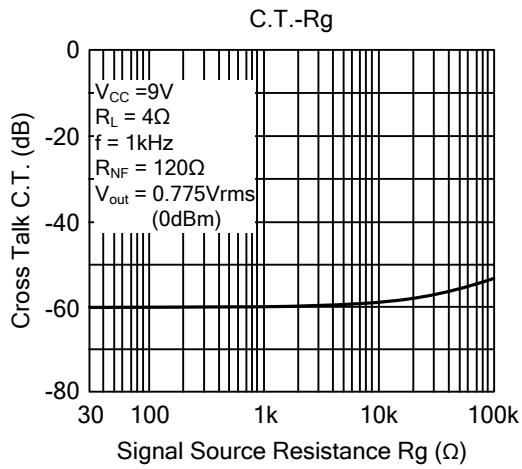

UTC assumes no responsibility for equipment failures that result from using products at values that exceed, even momentarily, rated values (such as maximum ratings, operating condition ranges, or other parameters) listed in products specifications of any and all UTC products described or contained herein. UTC products are not designed for use in life support appliances, devices or systems where malfunction of these products can be reasonably expected to result in personal injury. Reproduction in whole or in part is prohibited without the prior written consent of the copyright owner. UTC reserves the right to make changes to information published in this document, including without limitation specifications and product descriptions, at any time and without notice. This document supersedes and replaces all information supplied prior to the publication hereof.