



## TDA8496

## LINEAR INTEGRATED CIRCUIT

### 5W+5W AMPLIFIER WITH DC VOLUME CONTROL

#### DESCRIPTION

The UTC **TDA8496** is a stereo 5+5W class AB power amplifier with mute and dc volume control, assembled in the HZIP-15A/B/D package. It is designed for high quality sound, LCD TV or LCD Monitor applications.

#### FEATURES

- \* 5+5w output power @  $V_{CC}= 22V$ ;  $R_L = 8\Omega$
- \* Low turn-on turn-off pop noise
- \* Low external components
- \* Short circuit & thermal overload protection
- \* Linear volume control by DC voltage
- \* Soft clipping
- \* Internally fixed gain
- \* St-by and mute functions

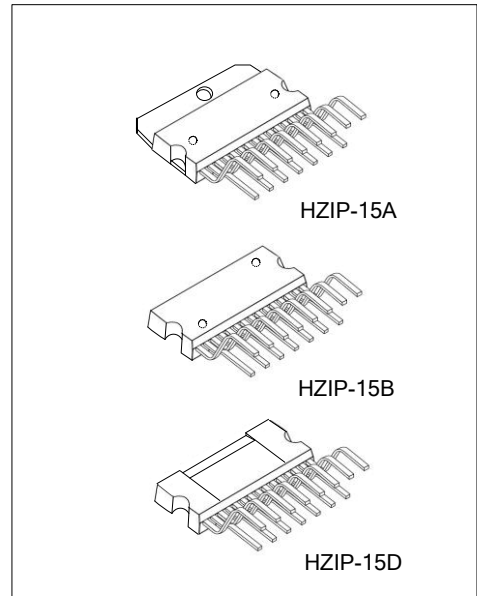

#### ORDERING INFORMATION

Ordering Number		Package	Packing
Lead Free	Halogen Free		
TDA8496L-J15-A-T	TDA8496G-J15-A-T	HZIP-15A	Tube
TDA8496L-J15-B-T	TDA8496G-J15-B-T	HZIP-15B	Tube
TDA8496L-J15-D-T	TDA8496G-J15-D-T	HZIP-15D	Tube

<p>TDA8496G-J15-A-T</p> <p>(1) Packing Type (2) Package Type (3) Green Package</p>	<p>(1) T: Tube (2) J15-A: HZIP-15A, J15-B: HZIP-15B J15-D: HZIP-15D (3) G: Halogen Free and Lead Free, L: Lead Free</p>
--	---

#### MARKING

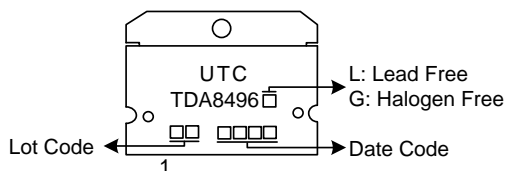

## PIN DESCRIPTION (TOP VIEW)

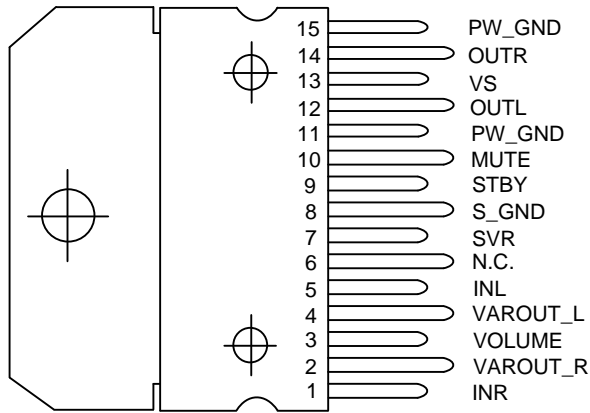

HZIP-15A

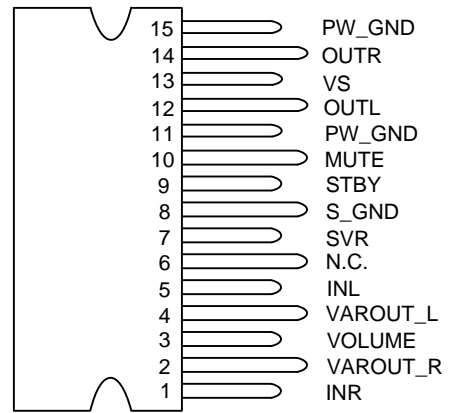

HZIP-15B/HZIP-15D

## BLOCK DIAGRAM

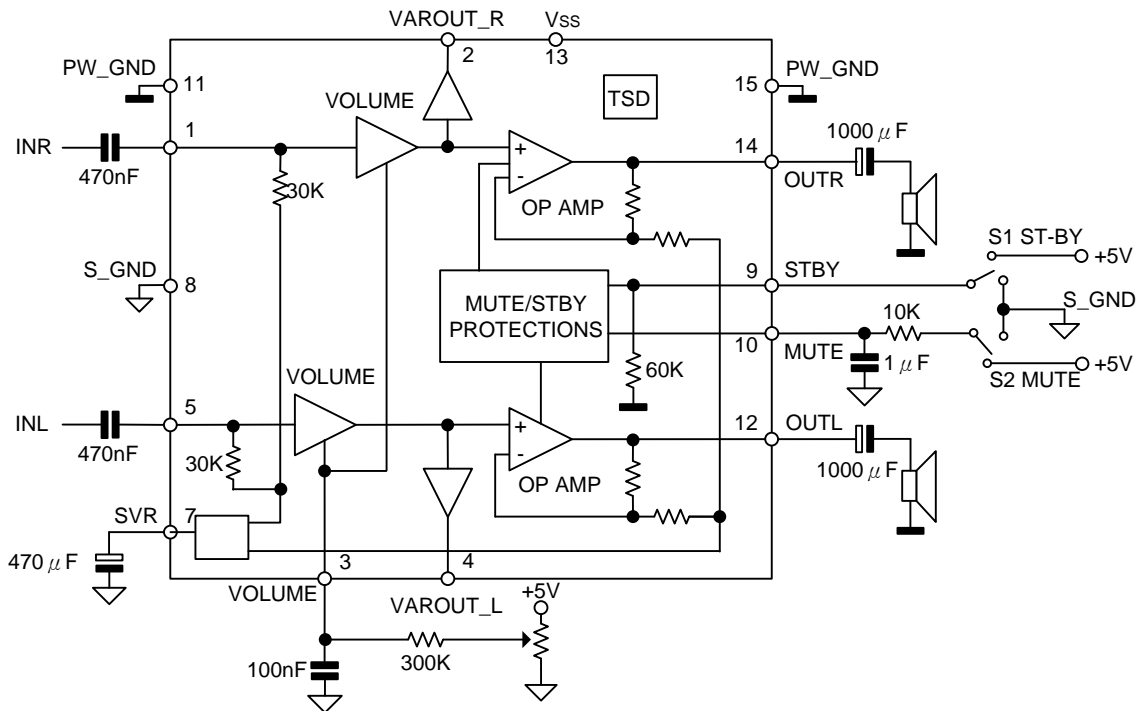

### ■ ABSOLUTE MAXIMUM RATINGS

PARAMETER		SYMBOL	RATINGS	UNIT
DC Supply voltage		$V_{SS}$	35	V
Maximum Input Voltage		$V_{IN(MAX)}$	8	$V_{PP}$
Volume Control DC Voltage		$V_3$	7	V
Power Dissipation ( $T_A=80^\circ\text{C}$ )	HZIP-15A/HZIP-15B	$P_D$	15	W
	HZIP-15D		12.5	
Junction Temperature		$T_J$	+150	$^\circ\text{C}$
Ambient Operating Temperature		$T_{OPR}$	0 ~ +70	$^\circ\text{C}$
Storage Temperature		$T_{STG}$	-40 ~ +150	$^\circ\text{C}$

Note: Absolute maximum ratings are those values beyond which the device could be permanently damaged. Absolute maximum ratings are stress ratings only and functional device operation is not implied.

### ■ THERMAL DATA

PARAMETER		SYMBOL	RATINGS	UNIT
Junction to Ambient	HZIP-15A/HZIP-15B	$\theta_{JA}$	35	$^\circ\text{C/W}$
	HZIP-15D		46	
Junction to Case	HZIP-15A/HZIP-15B	$\theta_{JC}$	4.6	$^\circ\text{C/W}$
	HZIP-15D		5.0	

### ■ ELECTRICAL CHARACTERISTICS (refer to the test circuit $V_{SS}=22\text{V}$ , $R_L=8\Omega$ , $R_G=50\Omega$ , $T_A=25^\circ\text{C}$ )

PARAMETER	SYMBOL	TEST CONDITIONS	MIN	TYP	MAX	UNIT
Supply Voltage Range	$V_{SS}$		10		32	V
Output DC Offset Referred to SVR Potential	$V_{OUT(OFF)}$	No Input Signal		200		mV
Quiescent Output Voltage	$V_{Q(OUT)}$			11		V
Output Power	$P_{OUT}$	THD = 10%, $R_L = 8\Omega$	5	5.5		W
		THD = 1%, $R_L = 8\Omega$		4		
		THD = 10%, $R_L = 4\Omega$ , $V_{SS} = 12\text{V}$		2.1		W
		THD = 1%, $R_L = 4\Omega$ , $V_{SS} = 12\text{V}$		1.0		
Total Harmonic Distortion	THD	$G_V = 30\text{dB}$ , $P_{OUT} = 1\text{W}$ , $f = 1\text{KHz}$			0.4	%
Total Quiescent Current	$I_Q$			25	50	mA
Output Peak Current	$I_{PEAK}$	(internally limited)	1.0	1.3		A
Input Signal	$V_{IN}$				2.8	Vrms
Closed Loop Gain	$G_V$	$V_{O(L\ CTRL)} > 4.5\text{V}$	28.5	30	31.5	dB
Monitor Out Gain	$G_{V(LINE)}$	$V_{O(L\ CTRL)} > 4.5\text{V}$ , $Z_{LOAD} > 30\text{K}\Omega$	-1.5	0	1.5	dB
Attenuation at Minimum Volume	$A_{MIN}$	$V_{O(L\ CTRL)} < 0.5\text{V}$	80			dB
Bandwidth	BW			0.6		MHz
Total Output Noise	$e_N$	$f = 20\text{Hz} \sim 22\text{KHz}$	PLAY, Max volume	500	800	$\mu\text{V}$
			PLAY, Max attenuation	100	250	$\mu\text{V}$
			Mute	60	150	$\mu\text{V}$
Slew Rate	SR		5	8		V/ $\mu\text{s}$
Input Resistance	$R_{IN}$		22.5	30		$\text{K}\Omega$
Variable Output Resistance	$R_{VAR(OUT)}$			30	100	$\Omega$
Variable Output Load	$R_{L(OUT)}$		2			$\text{K}\Omega$
Supply Voltage Rejection	SVR	$f=1\text{KHz}$ , $C_{SVR}=470\text{mF}$ , $V_{RIP}=1\text{Vrms}$	Max volume	35	39	dB
			Max attenuation	55	65	dB
Thermal Muting	$T_{MUTE}$			150		$^\circ\text{C}$
Thermal Shut-down	$T_{SHDN}$			160		$^\circ\text{C}$

### ■ ELECTRICAL CHARACTERISTICS (Cont.)

PARAMETER	SYMBOL	TEST CONDITIONS	MIN	TYP	MAX	UNIT
<b>MUTE STAND-BY &amp; INPUT SELECTION FUNCTIONS</b>						
Stand-by ON Threshold	$V_{THD(SON)}$		3.5			V
Stand-by OFF Threshold	$V_{THD(SOFF)}$				1.5	V
Mute ON threshold	$V_{THD(MON)}$		3.5			V
Mute OFF threshold	$V_{THD(MOFF)}$				1.5	V
Mute Attenuation	$A_{MUTE}$		50	65		dB
Quiescent Current @ Stand-by	$I_{Q(ST-BY)}$			0.6	1	mA
Stand-by Bias Current	$I_{ST-BY(BIAS)}$	Stand by ON: $V_{ST-BY} = 5V, V_{MUTE} = 5V$		80		$\mu A$
		Play or Mute	-20	-5		$\mu A$
Mute Bias Current	$I_{MUTE(BIAS)}$	Mute		1	5	$\mu A$

## ■ TYPICAL APPLICATION CIRCUIT

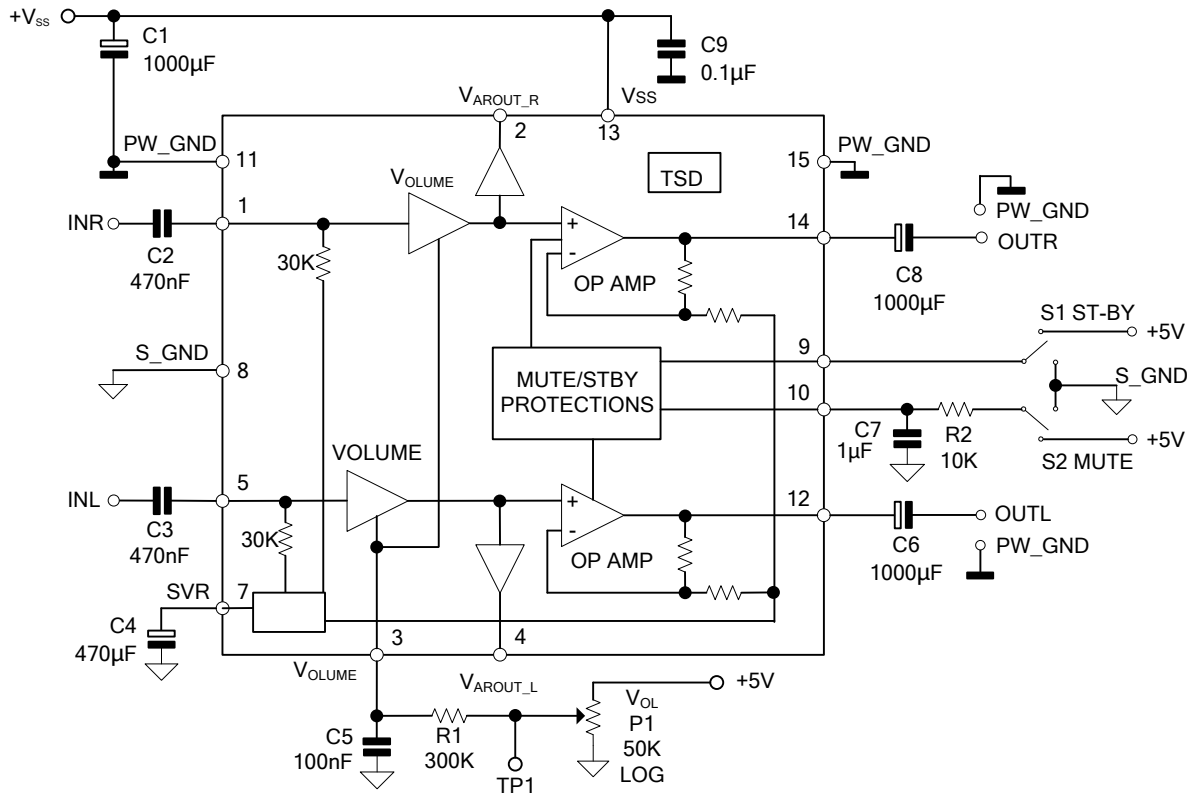

Fig. 1 Application Circuit

MUTE STAND-BY TRUTH TABLE

MUTE	STAND-BY	OPERATING CONDITION
H	H	STAND-BY
L	H	STAND-BY
H	L	MUTE
L	L	PLAY

## ■ TYPICAL APPLICATION CIRCUIT (Cont.)

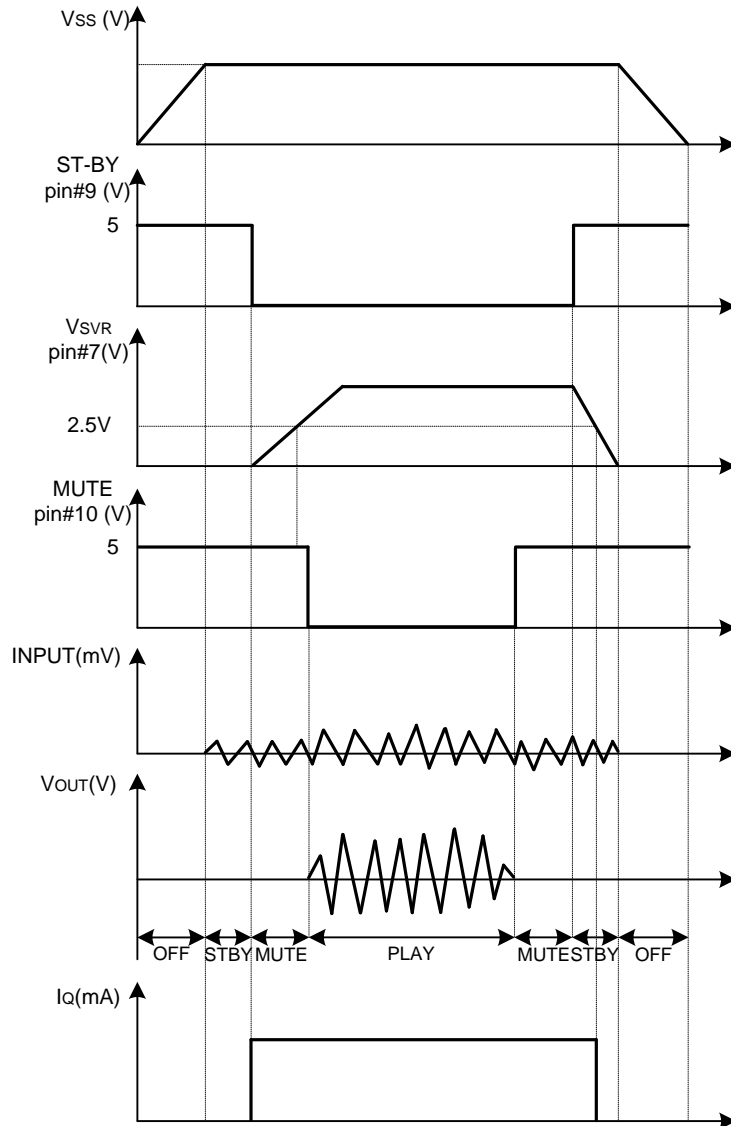
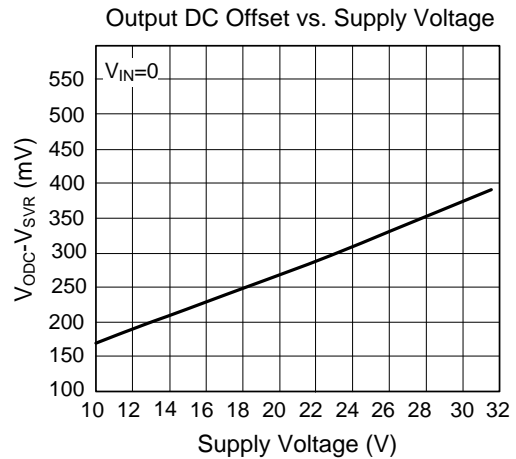
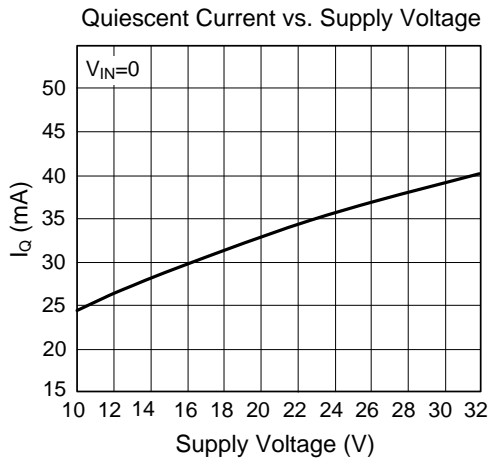
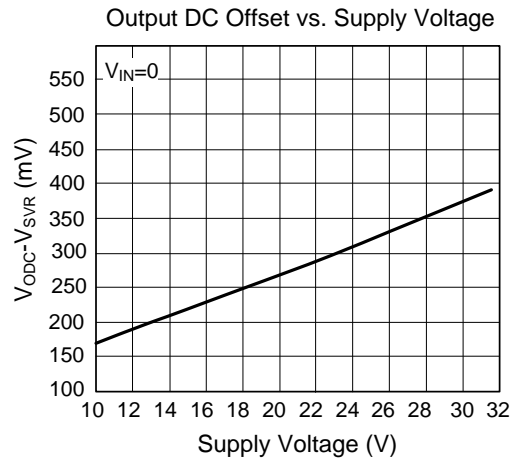
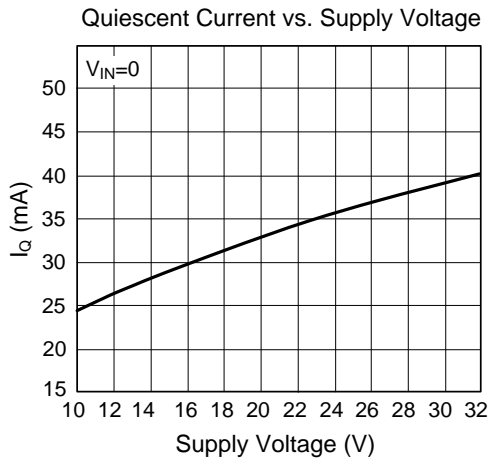

Fig. 2 Turn ON/OFF Sequences (use only the MUTE function)

## ■ TYPICAL CHARACTERISTICS



UTC assumes no responsibility for equipment failures that result from using products at values that exceed, even momentarily, rated values (such as maximum ratings, operating condition ranges, or other parameters) listed in products specifications of any and all UTC products described or contained herein. UTC products are not designed for use in life support appliances, devices or systems where malfunction of these products can be reasonably expected to result in personal injury. Reproduction in whole or in part is prohibited without the prior written consent of the copyright owner. UTC reserves the right to make changes to information published in this document, including without limitation specifications and product descriptions, at any time and without notice. This document supersedes and replaces all information supplied prior to the publication hereof.