



F1962

LINEAR INTEGRATED CIRCUIT

SINGLE-PHASE FULL-WAVE MOTOR DRIVER IC

DESCRIPTION

The UTC **F1962** is a Single-phase full-wave motor driver designed specially for small DC fans. For example, CPU cooling fans.

FEATURES

- * Wide Operating Voltage 5V or 12V Are Both Acceptable
- * Built-In Hall Amplifier And Hall Bias Circuit
- * Built-In Lockup And Thermal Protection With Automatic Recovery Circuits
- * Rotation Detection Output
- * Start/Stop Pin For Standby Mode Control

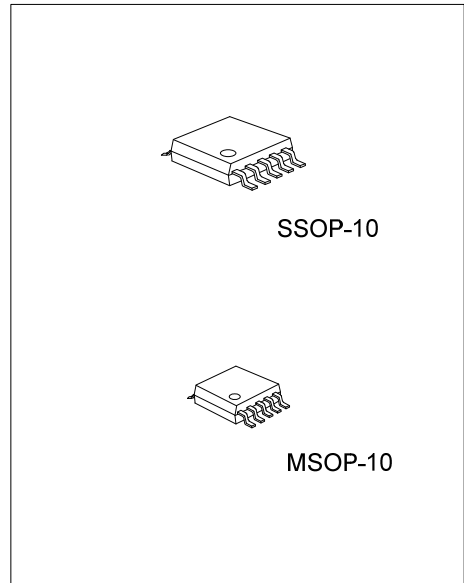

ORDERING INFORMATION

| Ordering Number | | Package | Packing |
|-----------------|--------------|---------|-----------|
| Lead Free | Halogen Free | | |
| F1962L-R10-T | F1962G-R10-T | SSOP-10 | Tube |
| F1962L-R10-R | F1962G-R10-R | SSOP-10 | Tape Reel |
| F1962L-SM2-T | F1962G-SM2-T | MSOP-10 | Tube |
| F1962L-SM2-R | F1962G-SM2-R | MSOP-10 | Tape Reel |

| | |
|---|---|
| <p>F1962G-R10-T</p> <p>(1)Packing Type</p> <p>(2)Package Type</p> <p>(3)Green Package</p> | <p>(1) T: Tube, R: Tape Reel</p> <p>(2) R10: SSOP-10, SM2: MSOP-10</p> <p>(3) G: Halogen Free and Lead Free, L: Lead Free</p> |
|---|---|

MARKING

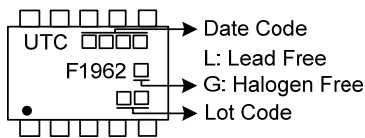

■ PIN CONFIGURATION

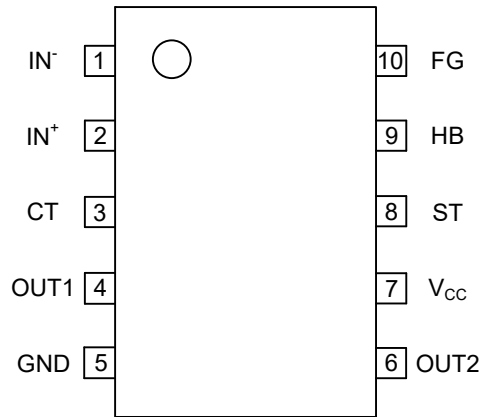

■ BLOCK DIAGRAM

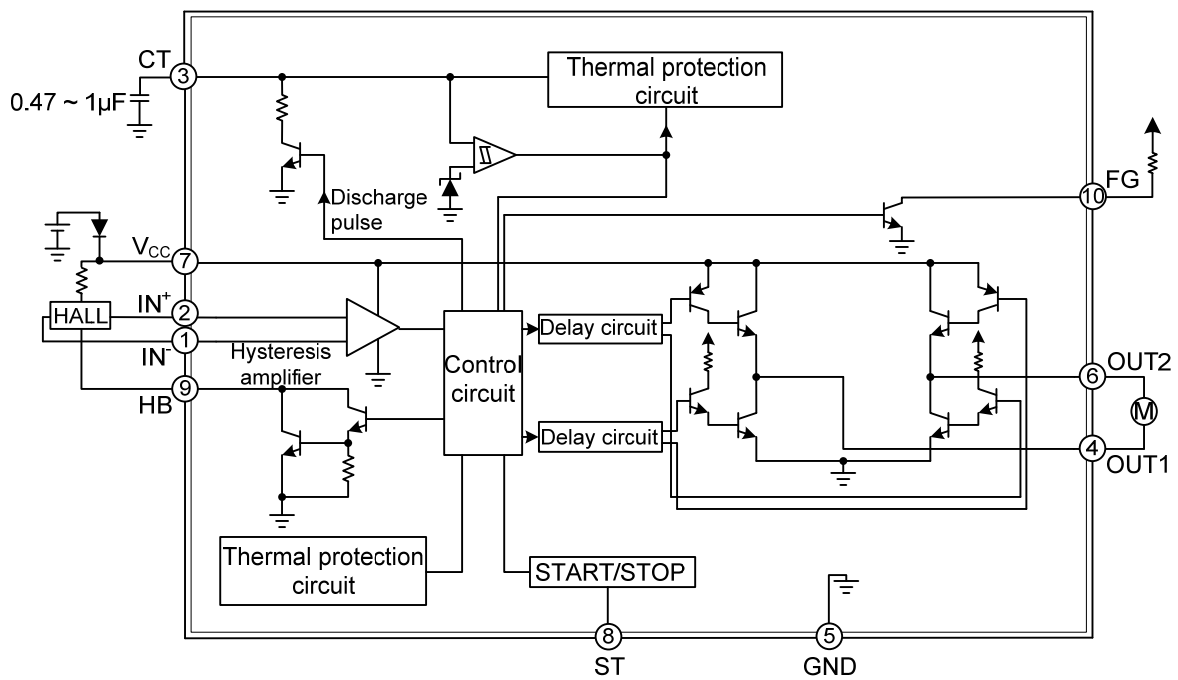

■ ABSOLUTE MAXIMUM RATING ($T_A=25^\circ\text{C}$, unless otherwise specified)

| PARAMETER | SYMBOL | RATINGS | UNIT | |
|--|----------------|------------|------------------|----|
| Maximum Supply Voltage | $V_{CC(max)}$ | 18 | V | |
| Maximum Output Current | $I_{OUT(max)}$ | 0.5 | A | |
| Maximum Output Withstand Voltage | $V_{OUT(max)}$ | 18 | V | |
| Maximum Output Withstand Voltage | $V_F(max)$ | 17 | V | |
| Maximum Output Current | $I_F(max)$ | 5 | mA | |
| | $I_R(max)$ | 5 | mA | |
| HB Maximum Output Current | $I_B(max)$ | 10 | mA | |
| ST Maximum Input Voltage | $V_{ST(max)}$ | 15 | V | |
| Allowable Power Dissipation (With Specified Substrate(Note 2)) | SSOP-10 | P_D | 800 | mW |
| | MSOP-10 | | 650 | mW |
| Junction Temperature | T_J | +150 | $^\circ\text{C}$ | |
| Operating Temperature | T_{OPR} | -30 ~ +85 | $^\circ\text{C}$ | |
| Storage Temperature | T_{STG} | -40 ~ +150 | $^\circ\text{C}$ | |

Notes: 1. Absolute maximum ratings are those values beyond which the device could be permanently damaged.

Absolute maximum ratings are stress ratings only and functional device operation is not implied.

2. Specified substrate: 114.3×76.2×1.5mm³ glass epoxy.

■ RECOMMENDED OPERATING RATINGS ($T_A=25^\circ\text{C}$, unless otherwise specified)

| PARAMETER | SYMBOL | RATINGS | UNIT |
|--------------------------------------|-----------|--------------------|------|
| Power Supply Voltage | V_{CC} | 3.8 ~ 16.8 | V |
| ST Input High Level Voltage | ST_H | 3 ~ 14 | V |
| ST Input Low Level Voltage | ST_L | -0.3 ~ +0.4 | V |
| Hall Input Common Mode Voltage Range | V_{ICM} | 0.2 ~ $V_{CC}-1.5$ | V |

■ ELECTRICAL CHARACTERISTICS ($V_{CC}=5\text{V}$, $T_A=25^\circ\text{C}$, unless otherwise specified)

| PARAMETER | SYMBOL | TEST CONDITIONS | MIN | TYP | MAX | UNIT |
|--|------------|--|------|------|------|---------------|
| Current Drain | I_{CC} | In drive mode (CT=[L], ST=[L]) | | 8.0 | 10 | mA |
| | | In lockup protection mode (CT=[H], ST=[L]) | | 2.2 | 3.1 | mA |
| | | In standby mode (ST=[H]) | | 110 | 150 | μA |
| Lockup Detection Capacitor Charge Current | I_{CT}^1 | | 1.9 | 3.0 | 4.1 | μA |
| Capacitor discharge current | I_{CT}^2 | | 0.32 | 0.50 | 0.68 | μA |
| Capacitor Charge/Discharge Current Ratio | R_{CT} | $R_{CD}=I_{CT}^1/I_{CT}^2$ | 5.5 | 6.5 | 7.5 | |
| CT Charge Voltage | V_{CT}^1 | | 2.55 | 2.75 | 2.95 | V |
| CT Discharge Voltage | V_{CT}^2 | | 1.6 | 1.8 | 2.0 | V |
| Output Low Level Voltage | V_{OL} | $I_O=200\text{mA}$ | | 0.2 | 0.3 | V |
| Output High Level Voltage | V_{OH} | $I_O=200\text{mA}$ | 3.9 | 4.1 | | V |
| Hall Input Sensitivity | V_{HN} | Zero peak value (Including offset and hysteresis) | | 7 | 15 | mV |
| Output Pin Low Voltage | V_{FG} | $I_{FG}=5\text{mA}$ | | 0.1 | 0.3 | V |
| Output Pin Leakage Current | I_{FGL} | $V_{FG}=15\text{V}$ | | | 30 | μA |
| HB Output Low Voltage | V_{HBL} | $I_{HB}=5\text{mA}$ | | 1.0 | 1.3 | V |
| ST Pin Input Current | I_{ST} | $V_{ST}=5\text{V}$ | | 75 | 100 | μA |

■ TRUTH TABLE

| ST | IN ⁻ | IN ⁺ | CT | OUT1 | OUT2 | FG | HB | Mode |
|----|-----------------|-----------------|----|------|------|-----|-----|-----------------------------|
| H | | | | off | off | off | off | Standby |
| L | H | L | L | H | L | H | L | Rotating |
| | L | H | | L | H | L | | |
| | | | H | off | off | | L | Lockup protection activated |

■ DESIGN REFERENCE

(1) V_{CC} pin

Power supply pin for whole IC.

(2) OUT1, OUT2 pins

Single-phase coil output pins.

Bipolar forward or reverse drive output determined by OUT1 or OUT2 high. Built-in regenerative circuit that regenerates kickback current between lower side NPN outputs if a diode is used for protection against reverse connection.

(3) IN⁻, IN⁺ pins

Hall signal input pins

The Hall signal is amplified into a square wave by the Hall amplifier with hysteresis characteristics of ± 3.5 mV (typ.). The Hall signal amplitude should be 70 mV or more.

(4) CT pin

This pin serves timing capacitor connecting pin between CT and GND.

The capacitor determines timing of the built-in lockup protection circuit for preventing coil burnout when motor is locked. Once normal motor rotating condition is restored, the automatic recovery circuit will reset itself.

Adjusting the capacitance alters the lockup detection time.

When a 0.47 μ F capacitor is connected between CT and GND.

Lockup detection time : approx. 0.5s
 Lockup protection time/automatic recovery time : approx. 0.16s (output ON)
 : approx. 1s (output OFF)

Connecting this pin to ground when lockup function is not used

(6) FG pin

Open-collector output pin for rotation frequency detection.

When IN⁻ = High and IN⁺ = Low, then FG = Low

When IN⁻ = Low and IN⁺ = High, then FG = High

(7) ST pin and HB pin

ST pin: When input to this pin is High, motor drive is stopped (OUT is high impedance).

HB pin: Hall bias switching pin. At ST pin High input, Hall bias is switched to reduce current drain in fan standby mode.

If not used, both pins should be open.

(8) Thermal protection circuit

When junction temperature T_J of IC is or over about 150°C, output current limiter is activated to protect against damage.

■ SAMPLE APPLICATION CIRCUIT

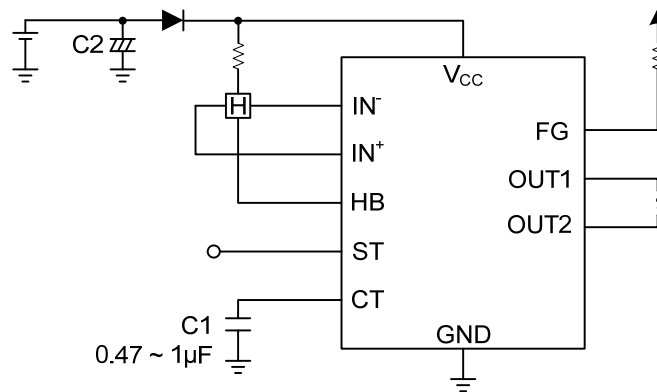

Startup

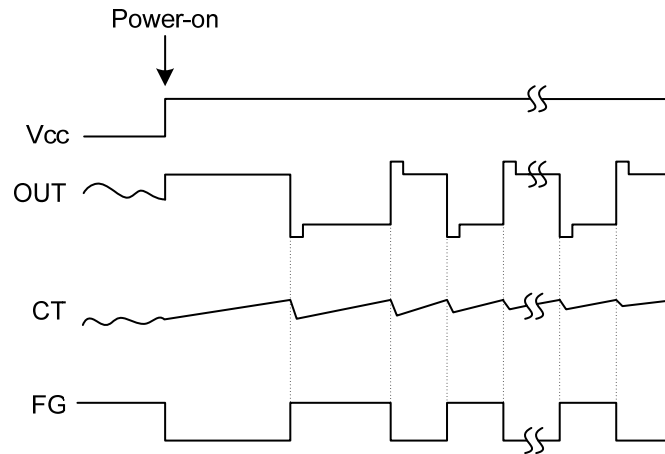

■ SAMPLE APPLICATION CIRCUIT (Cont.)

Locked-up protection and automatic recovery curves

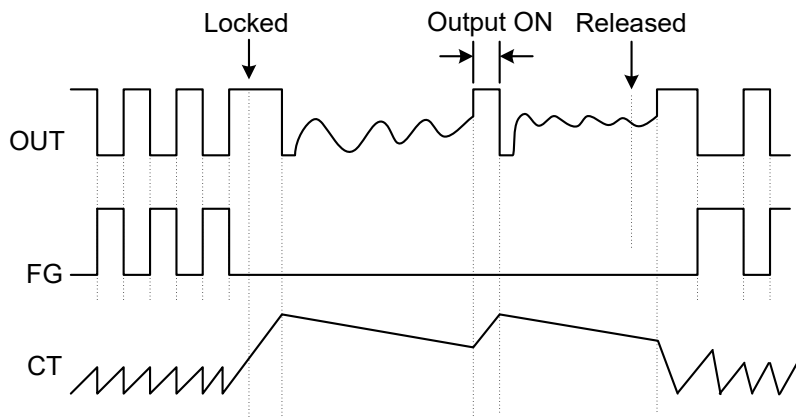

Start or stop curve

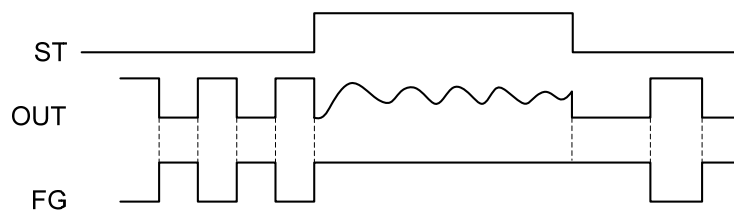

■ TYPICAL CHARACTERISTICS

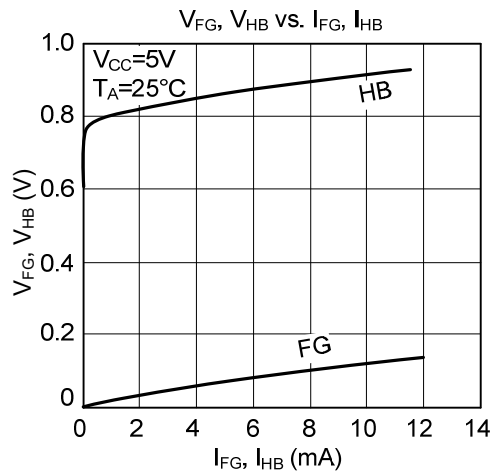
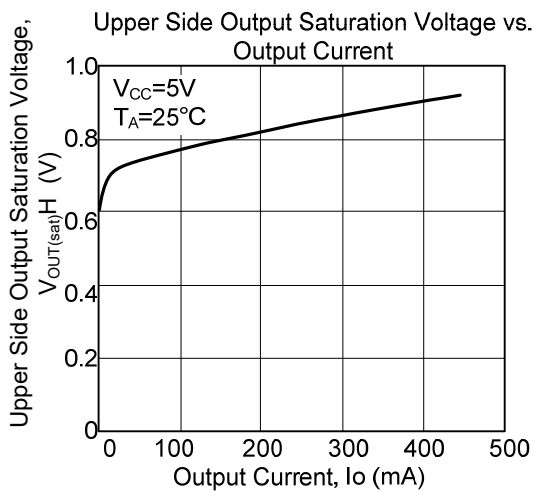
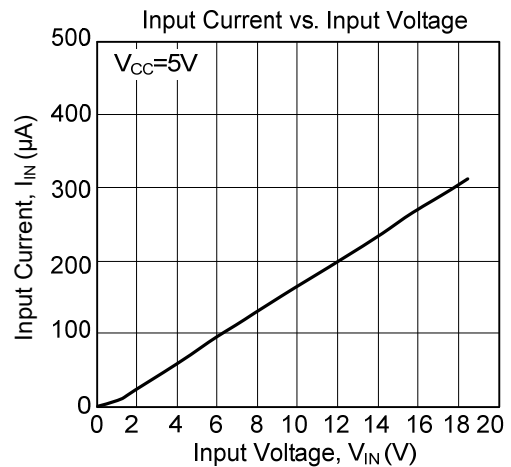
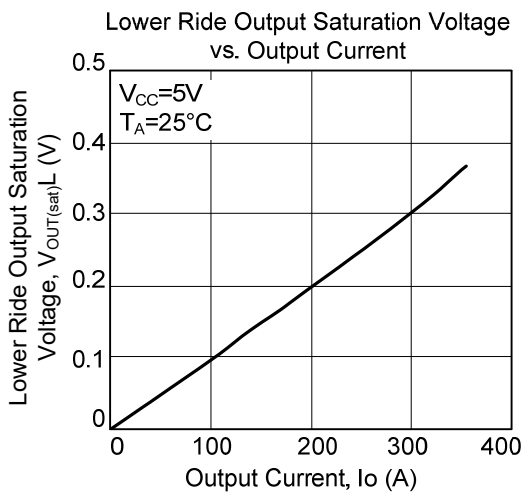
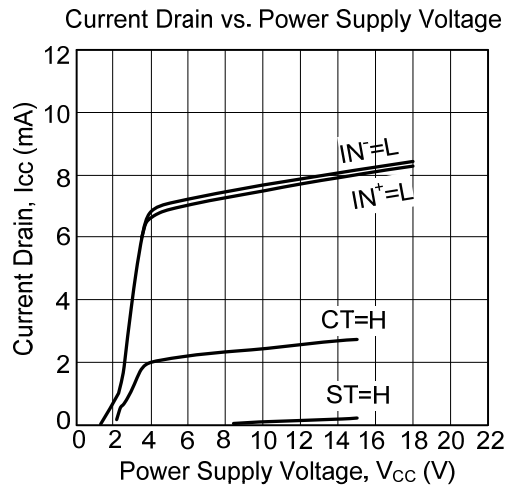
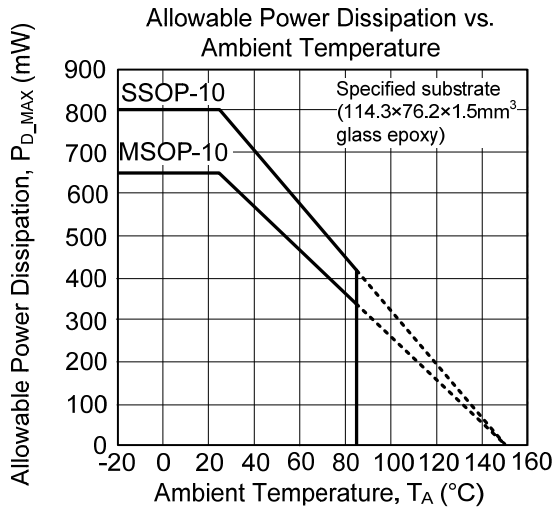

UTC assumes no responsibility for equipment failures that result from using products at values that exceed, even momentarily, rated values (such as maximum ratings, operating condition ranges, or other parameters) listed in products specifications of any and all UTC products described or contained herein. UTC products are not designed for use in life support appliances, devices or systems where malfunction of these products can be reasonably expected to result in personal injury. Reproduction in whole or in part is prohibited without the prior written consent of the copyright owner. UTC reserves the right to make changes to information published in this document, including without limitation specifications and product descriptions, at any time and without notice. This document supersedes and replaces all information supplied prior to the publication hereof.