



U74LVC2G66

CMOS IC

DUAL BILATERAL ANALOG SWITCH

DESCRIPTION

The **U74LVC2G66** is a dual bilateral analog switch which is designed for 1.65V to 5.5V operation. This switch can handle both analog and digital signals and permits signals with amplitudes of up to 5.5 V (peak) to be transmitted in either direction. Each switch section has enable-input control (C). If the voltage applied to C is at high-level, the associated switch section is turned on.

FEATURES

- * Wide Supply Voltage Range from 1.65V to 5.5V
- * Up to 5.5V Inputs Accept Voltages
- * Max t_{PD} of 0.8 ns at 3.3V
- * High ON-OFF Output Voltage Ratio
- * High Degree Of Linearity
- * High Speed, Typically 0.5 ns at $V_{CC} = 3 V, C_L = 50 pF$
- * Rail-to-Rail Input/Output
- * Low On-State Resistance, Typically 6 Ω at $V_{CC} = 4.5 V$

ORDERING INFORMATION

Ordering Number		Package	Packing
Lead Free	Halogen Free		
U74LVC2G66L-S08-R	U74LVC2G66G-S08-R	SOP-8	Tape Reel
U74LVC2G66L- SM1-R	U74LVC2G66G- SM1-R	MSOP-8	Tape Reel
U74LVC2G66L-P08-R	U74LVC2G66G-P08-R	TSSOP-8	Tape Reel
U74LVC2G66L-K08-2030-R	U74LVC2G66G-K08-2030-R	DFN2030-8	Tape Reel
U74LVC2G66L-CK08-2030-R	U74LVC2G66G-CK08-2030-R	CDFN2030-8	Tape Reel

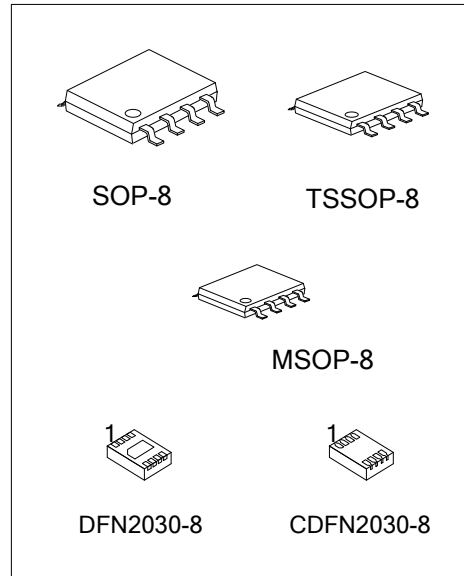

<p>U74LVC2G66G-S08-R</p> <p>(1) Packing Type</p> <p>(2) Package Type</p> <p>(3) Green Package</p>	<p>(1) R: Tape Reel</p> <p>(2) S08: SOP-8, SM1: MSOP-8, P08: TSSOP-8</p> <p>K08-2030: DFN2030-8, CK08-2030: CDFN2030-8</p> <p>(3) G: Halogen Free and Lead Free, L: Lead Free</p>
---	---

MARKING

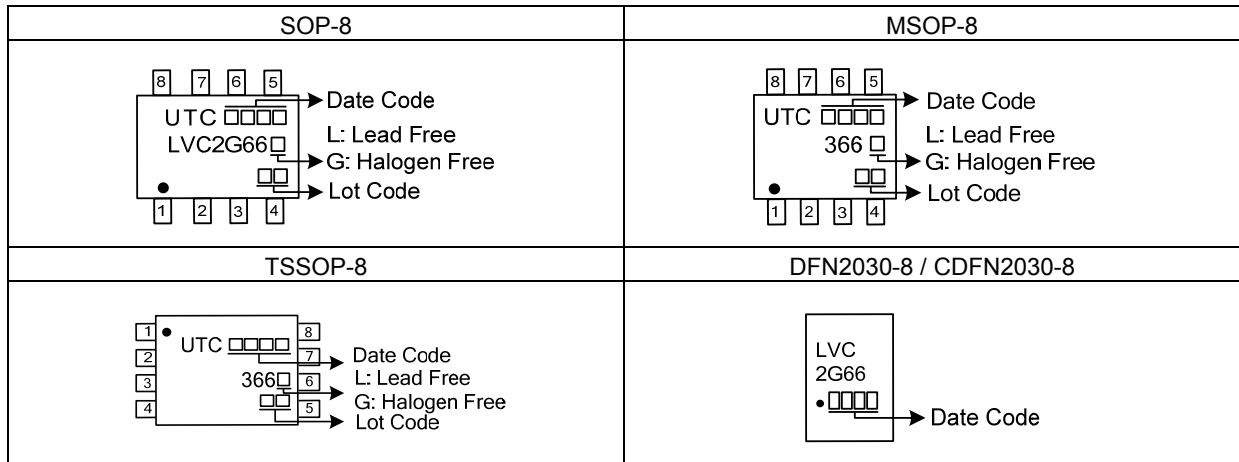

PIN CONFIGURATION

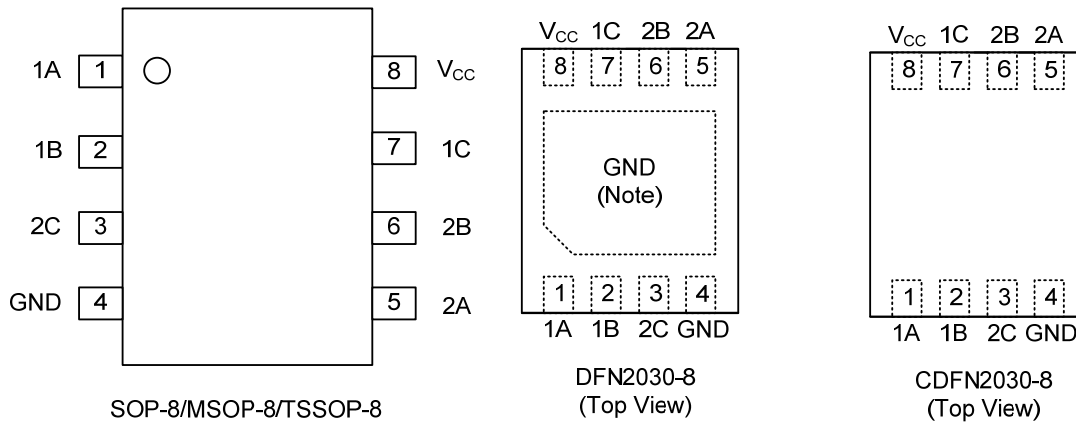

Note: Connect exposed pad to GND.

FUNCTION TABLE (Each Gate)

CONTROL INPUT (C)	SWITCH
L	Off
H	On

LOGIC DIAGRAM (Positive Logic)

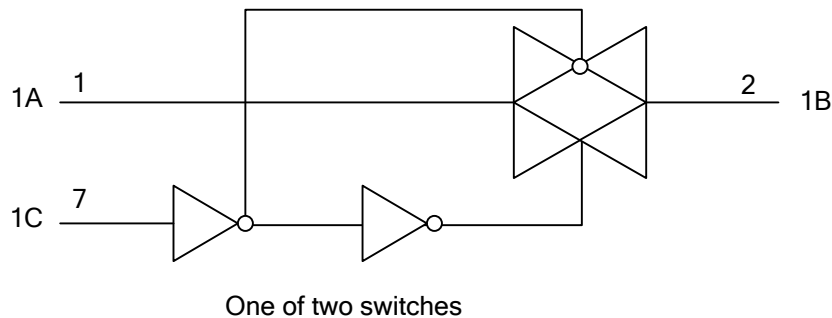

■ ABSOLUTE MAXIMUM RATING (T_A=25°C, unless otherwise specified)

PARAMETER	SYMBOL	RATINGS	UNIT
Supply Voltage	V _{CC}	-0.5~6.5	V
Input Voltage	V _{IN}	-0.5~6.5	V
Switch I/O Voltage	V _{OUT}	-0.5~V _{CC} +0.5	V
Control Input Clamp Current	I _{IK}	-50	mA
I/O Port Diode Current	I _{I/O}	-50	mA
On-State Switch Current	I _{OUT}	±50	mA
V _{CC} or GND Current	I _{CC}	±100	mA
Junction Temperature	T _J	+150	°C
Storage Temperature	T _{STG}	-65 ~ +150	°C

Notes: 1. The input and output voltage ratings may be exceeded if the input and output current ratings are observed.
 2. Absolute maximum ratings are those values beyond which the device could be permanently damaged.
 Absolute maximum ratings are stress ratings only and functional device operation is not implied.

■ THERMAL DATA

PARAMETER	SYMBOL	RATINGS	UNIT
Junction to Ambient	θ _{JA}	150	°C/W
		220	
		190	
		59	
		230	

■ RECOMMENDED OPERATING CONDITIONS

PARAMETER	SYMBOL	CONDITIONS	MIN	TYP	MAX	UNIT
Supply Voltage	V _{CC}	Operating	1.65		5.5	V
I/O Port Voltage	V _{I/O}		0		V _{CC}	V
High-Level Input Voltage, Control Input	V _{IH}	V _{CC} = 1.65V to 1.95V	0.65×V _{CC}			V
		V _{CC} = 2.3V to 2.7V	0.7×V _{CC}			
		V _{CC} = 3V to 3.6V	0.7×V _{CC}			
		V _{CC} = 4.5V to 5.5V	0.7×V _{CC}			
Low-Level Input Voltage, Control Input	V _{IL}	V _{CC} = 1.65V to 1.95V			0.35×V _{CC}	V
		V _{CC} = 2.3V to 2.7V			0.3×V _{CC}	
		V _{CC} = 3V to 3.6V			0.3×V _{CC}	
		V _{CC} = 4.5V to 5.5V			0.3×V _{CC}	
Control Input Voltage	V _{IN}		0		5.5	V
Input Transition Rise or Fall Rate	t _R / t _F	V _{CC} = 1.65V to 1.95V			20	ns/V
		V _{CC} = 2.3V to 2.7V			20	
		V _{CC} = 3V to 3.6V			10	
		V _{CC} = 4.5V to 5.5V			10	
Operating Temperature	T _{OPR}		-40		+125	°C

■ ELECTRICAL CHARACTERISTICS (T_A=25°C, unless otherwise specified)

PARAMETER	SYMBOL	TEST CONDITIONS	MIN	TYP	MAX	UNIT
On-State Switch Resistance	r _{ON}	V _{IN} = V _{CC} or GND, V _C = V _{IH} , (see Fig.1)	I _S = 4mA, V _{CC} = 1.65 V	12.5	30	Ω
			I _S = 8mA, V _{CC} = 2.3 V	9	20	
			I _S = 24mA, V _{CC} = 3 V	7.5	15	
			I _S = 32mA, V _{CC} = 4.5 V	6	10	
Peak On-State Resistance	r _{ON(P)}	V _{IN} = V _{CC} to GND, V _C = V _{IH} , (see Fig.1)	I _S = 4mA, V _{CC} = 1.65 V	85	120	Ω
			I _S = 8mA, V _{CC} = 2.3 V	22	30	
			I _S = 24mA, V _{CC} = 3 V	12	20	
			I _S = 32mA, V _{CC} = 4.5 V	7.5	15	
Difference of On-State Resistance Between Switches	Δr _{ON}	V _{IN} = V _{CC} to GND, V _C = V _{IH} , (see Fig.1)	I _S = 4mA, V _{CC} = 1.65 V		7	Ω
			I _S = 8mA, V _{CC} = 2.3 V		5	
			I _S = 24mA, V _{CC} = 3 V		3	
			I _S = 32mA, V _{CC} = 4.5 V		2	
Off-State Switch Leakage Current	I _{S(OFF)}	V _{IN} = V _{CC} and V _{OUT} = GND or V _{IN} = GND and V _{OUT} = V _{CC} , V _C = V _{IL} , V _{CC} = 5.5V (see Figure 2)			±0.1	μA
On-State Switch Leakage Current	I _{S(ON)}	V _{IN} = V _{CC} or GND, V _C = V _{IH} , V _{OUT} = Open, V _{CC} = 5.5V (see Figure 3)			±0.1	μA
Control Input Current	I _{IN}	V _C = V _{CC} or GND, V _{CC} = 5.5V			±0.1	μA
Quiescent Supply Current	I _Q	V _C = V _{CC} or GND, V _{CC} = 5.5V			1	μA
Additional Quiescent Supply Current	Δ I _Q	One input at V _{CC} - 0.6V; V _{CC} = 5.5V; other inputs at V _{CC} or GND			500	μA
Control Input Capacitance	C _{IN}	V _{CC} = 5.0V		3.5		pF
Switch Input/Output Capacitance	C _{IO(OFF)}	V _{CC} = 5.0V		6		pF
Switch Input/Output Capacitance	C _{IO(ON)}	V _{CC} = 5.0V		14		pF

■ SWITCHING CHARACTERISTICS (T_A=25°C, unless otherwise specified)

PARAMETER	SYMBOL	TEST CONDITIONS	MIN	TYP	MAX	UNIT
Propagation Delay From Input (A or B) to Output (B or A)	t _{PLH} / t _{PHL} (t _{PD})	C _L = 30pF	V _{CC} = 1.8±0.15V, R _L = 1KΩ		2	ns
			V _{CC} = 2.5±0.2V, R _L = 500Ω		1.2	
		C _L = 50pF	V _{CC} = 3.3±0.3V, R _L = 500Ω		0.8	
			V _{CC} = 5.0±0.5V, R _L = 500Ω		0.6	
Propagation Delay From Input (C) to Output (A or B)	t _{PZL} / t _{PZH} (t _{EN})	C _L = 30pF	V _{CC} = 1.8±0.15V, R _L = 1KΩ	2.3	10	ns
			V _{CC} = 2.5±0.2V, R _L = 500Ω	1.6	5.6	
		C _L = 50pF	V _{CC} = 3.3±0.3V, R _L = 500Ω	1.5	4.4	
			V _{CC} = 5.0±0.5V, R _L = 500Ω	1.3	3.9	
Propagation Delay From Input (C) to Output (A or B)	t _{PLZ} / t _{PHZ} (t _{DIS})	C _L = 30pF	V _{CC} = 1.8±0.15V, R _L = 1KΩ	2.5	10.5	ns
			V _{CC} = 2.5±0.2V, R _L = 500Ω	1.2	6.9	
		C _L = 50pF	V _{CC} = 3.3±0.3V, R _L = 500Ω	2	7.2	
			V _{CC} = 5.0±0.5V, R _L = 500Ω	1.1	6.3	

■ ANALOG SWITCHING CHARACTERISTICS (T_A=25°C, unless otherwise specified) (Note)

PARAMETER	SYMBOL	TEST CONDITIONS	MIN	TYP	MAX	UNIT
Frequency Response (Switch On) From Input (A or B) to Output (B or A)	f _{MAX}	C _L = 50 pF, R _L = 600 Ω, f _{IN} = sine wave (see Fig.4)	V _{CC} = 1.65 V	35		MHz
			V _{CC} = 2.3 V	120		
			V _{CC} = 3 V	175		
			V _{CC} = 4.5 V	195		
		C _L = 5 pF, R _L = 50 Ω, f _{IN} = sine wave (see Fig.4)	V _{CC} = 1.65 V	>300		
			V _{CC} = 2.3 V	>300		
			V _{CC} = 3 V	>300		
			V _{CC} = 4.5 V	>300		
Crosstalk (Note) (Between Switches) From Input (A or B) to Output (B or A)	V _{CT} (S _W , S _W)	C _L = 50 pF, R _L = 600 Ω, f _{IN} = 1 MHz (sine wave) (see Fig.6)	V _{CC} = 1.65 V	-58		dB
			V _{CC} = 2.3 V	-58		
			V _{CC} = 3 V	-58		
			V _{CC} = 4.5 V	-58		
		C _L = 5 pF, R _L = 50 Ω, f _{IN} = 1 MHz (sine wave) (see Fig.6)	V _{CC} = 1.65 V	-42		
			V _{CC} = 2.3 V	-42		
			V _{CC} = 3 V	-42		
			V _{CC} = 4.5 V	-42		
Crosstalk (Control Input To Signal Output) From Input (C) to Output (B or A)	V _{OT} (C _{ti} , S _W)	C _L = 50 pF, R _L = 600 Ω, f _{IN} = 1MHz (sine wave) (see Fig.7)	V _{CC} = 1.65 V	35		mV
			V _{CC} = 2.3 V	50		
			V _{CC} = 3 V	70		
			V _{CC} = 4.5 V	100		
Feedthrough Attenuation (Switch Off) From Input (A or B) to Output (B or A)	α _{off(f_r)}	C _L = 50 pF, R _L = 600 Ω, f _{IN} = 1MHz (sine wave) (see Fig.8)	V _{CC} = 1.65 V	-58		dB
			V _{CC} = 2.3 V	-58		
			V _{CC} = 3 V	-58		
			V _{CC} = 4.5 V	-58		
		C _L = 5 pF, R _L = 50 Ω, f _{IN} = 1MHz (sine wave) (see Fig.8)	V _{CC} = 1.65 V	-42		
			V _{CC} = 2.3 V	-42		
			V _{CC} = 3 V	-42		
			V _{CC} = 4.5 V	-42		
Sine-Wave Distortion From Input (A or B) to Output (B or A)	D _{SIN}	C _L = 50 pF, R _L = 10 kΩ, f _{IN} = 1kHz (sine wave) (see Fig.9)	V _{CC} = 1.65 V	0.1		%
			V _{CC} = 2.3 V	0.025		
			V _{CC} = 3 V	0.015		
			V _{CC} = 4.5 V	0.01		
		C _L = 50 pF, R _L = 10 kΩ, f _{IN} = 10kHz (sine wave) (see Fig.9)	V _{CC} = 1.65 V	0.15		
			V _{CC} = 2.3 V	0.025		
			V _{CC} = 3 V	0.015		
			V _{CC} = 4.5 V	0.01		

Note: Adjust f_{IN} voltage to obtain 0dBm at input.

■ OPERATING CHARACTERISTICS (f=10MHz, T_A=25°C, unless otherwise specified)

PARAMETER	SYMBOL	TEST CONDITIONS	MIN	TYP	MAX	UNIT
Power Dissipation Capacitance	C _{PD}	V _{CC} = 1.8V		8		pF
		V _{CC} = 2.5V		9		
		V _{CC} = 3.3V		9.5		
		V _{CC} = 5V		11		

PARAMETER MEASUREMENT

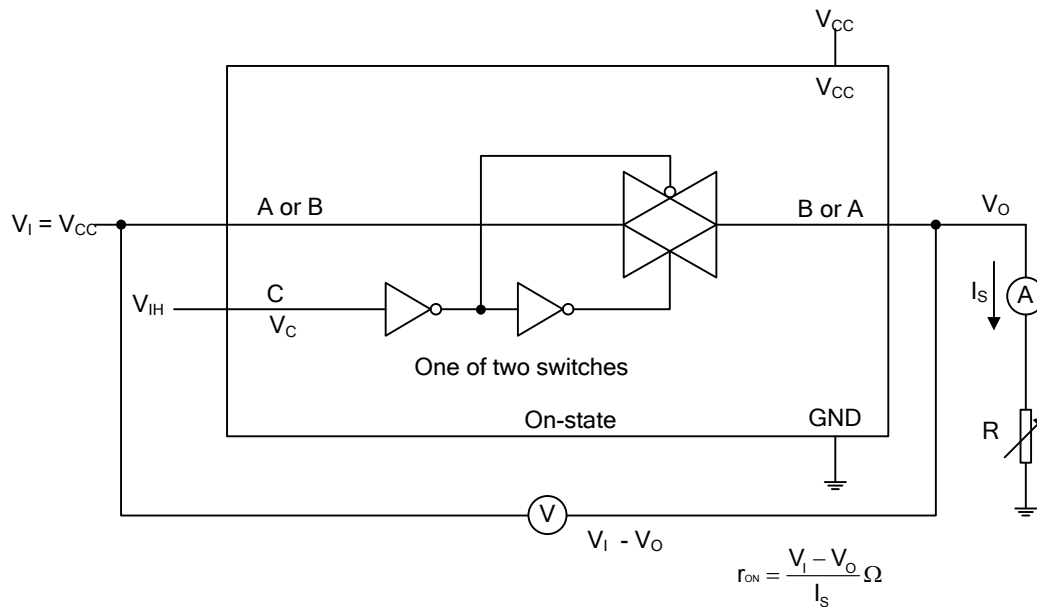
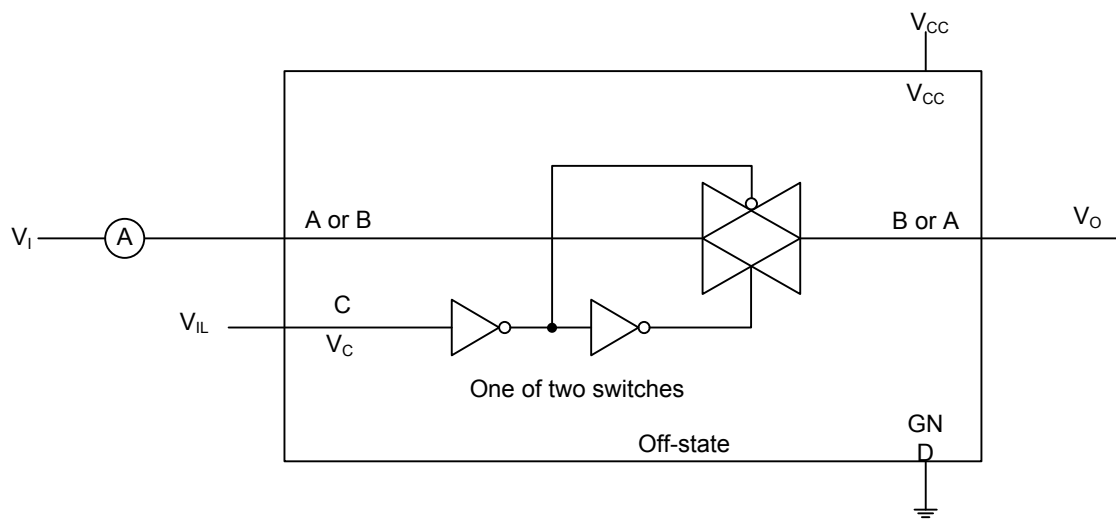

Fig.1 On-state resistance test circuit



Condition 1: $V_1 = \text{GND}, V_o = V_{CC}$

Condition 2: $V_1 = V_{CC}, V_o = \text{GND}$

Fig.2 Off-state switch leakage-current test circuit

■ PARAMETER MEASUREMENT (Cont.)

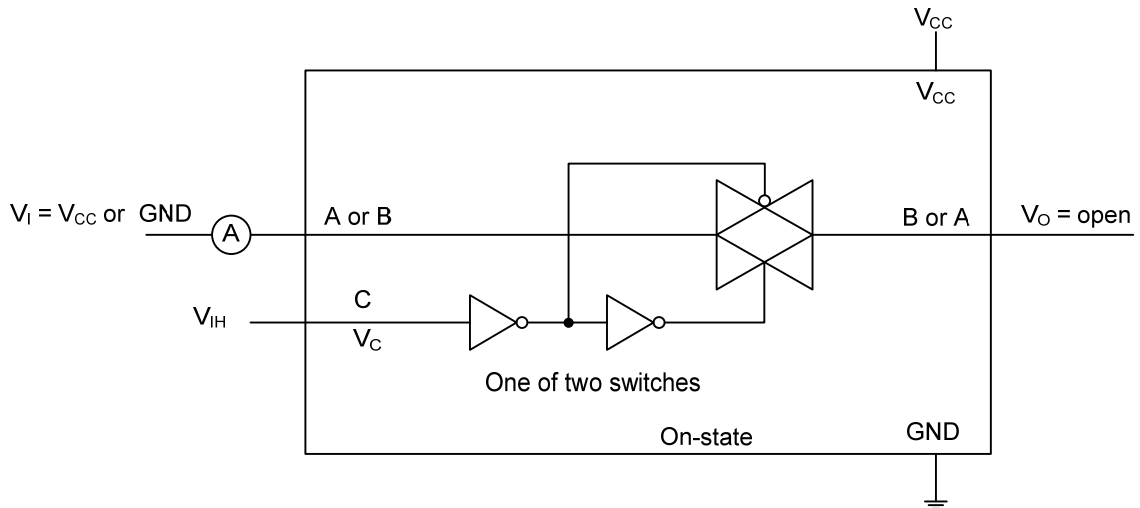
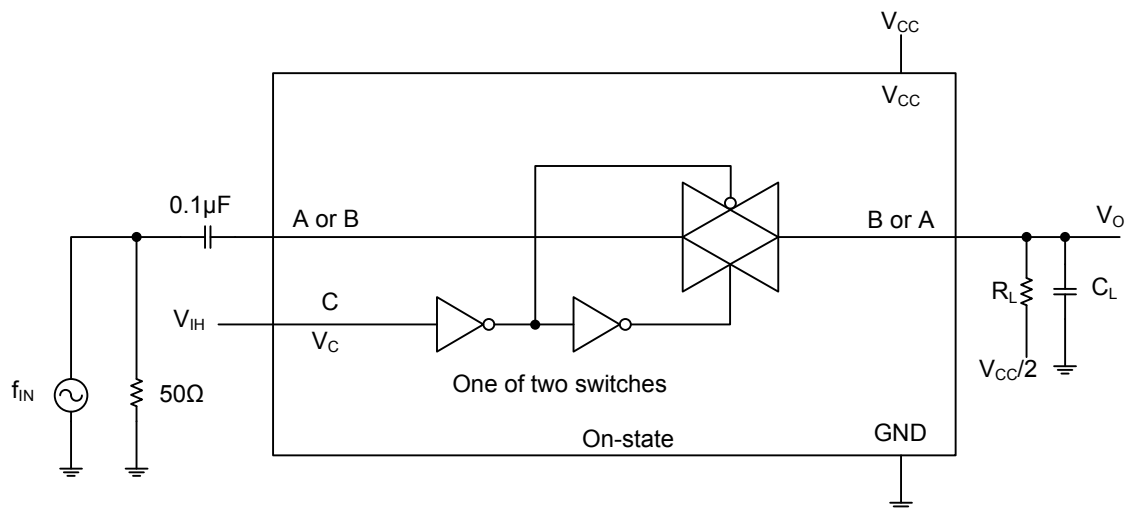

Fig.3 On-state leakage-current test circuit



$R_L/C_L : 600\Omega / 50\text{ pF}$

$R_L/C_L : 50\Omega / 5\text{ pF}$

Fig.4 Frequency response (switch on)

PARAMETER MEASUREMENT (Cont.)

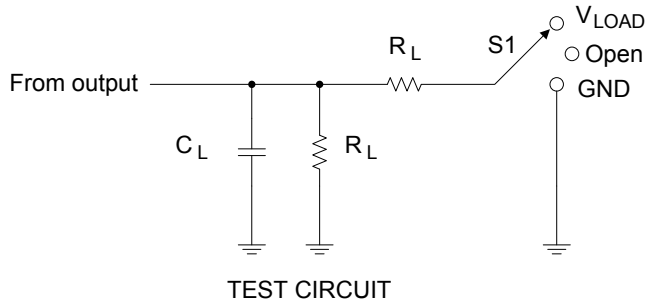

TEST	S1
t_{PLH} / t_{PHL}	Open
t_{PLZ} / t_{PZL}	V_{LOAD}
t_{PHZ} / t_{PZH}	GND

V_{CC}	Inputs		V_M	V_{LOAD}	C_L	R_L	V_{Δ}
	V_{IN}	t_R, t_F					
$1.8V \pm 0.15V$	V_{CC}	$\leq 2ns$	$V_{CC}/2$	$2 \times V_{CC}$	30pF	1K Ω	0.15V
$2.5V \pm 0.2V$	V_{CC}	$\leq 2ns$	$V_{CC}/2$	$2 \times V_{CC}$	30pF	500 Ω	0.15V
$3.3V \pm 0.3V$	V_{CC}	$\leq 2.5ns$	$V_{CC}/2$	$2 \times V_{CC}$	50pF	500 Ω	0.3V
$5V \pm 0.5V$	V_{CC}	$\leq 2.5ns$	$V_{CC}/2$	$2 \times V_{CC}$	50pF	500 Ω	0.3V

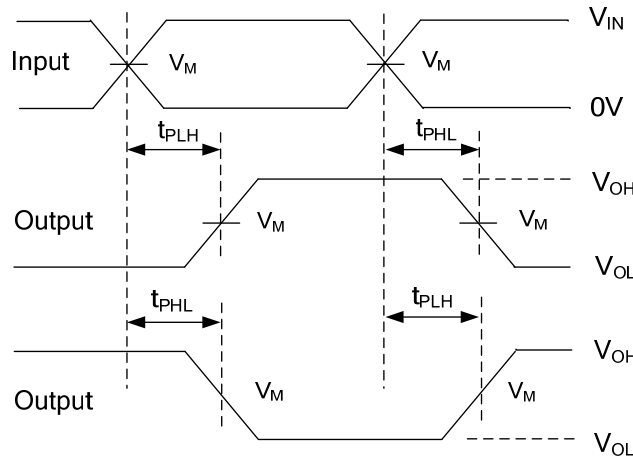

PROPAGATION DELAY TIMES

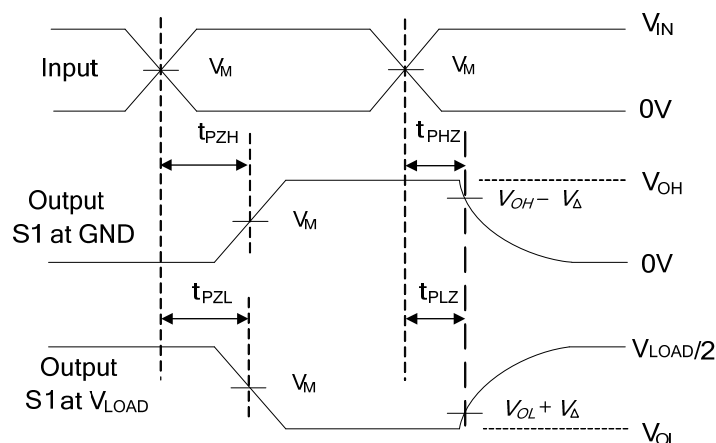

Enable and disable times
Low and high level enabling

Notes: 1. C_L includes probe and jig capacitance.

2. All input pulses are supplied by generators having the following characteristics: $P_{RR} \leq 10MHz$, $Z_O = 50\Omega$.

Fig.5 Load circuit and voltage waveforms

■ PARAMETER MEASUREMENT (Cont.)

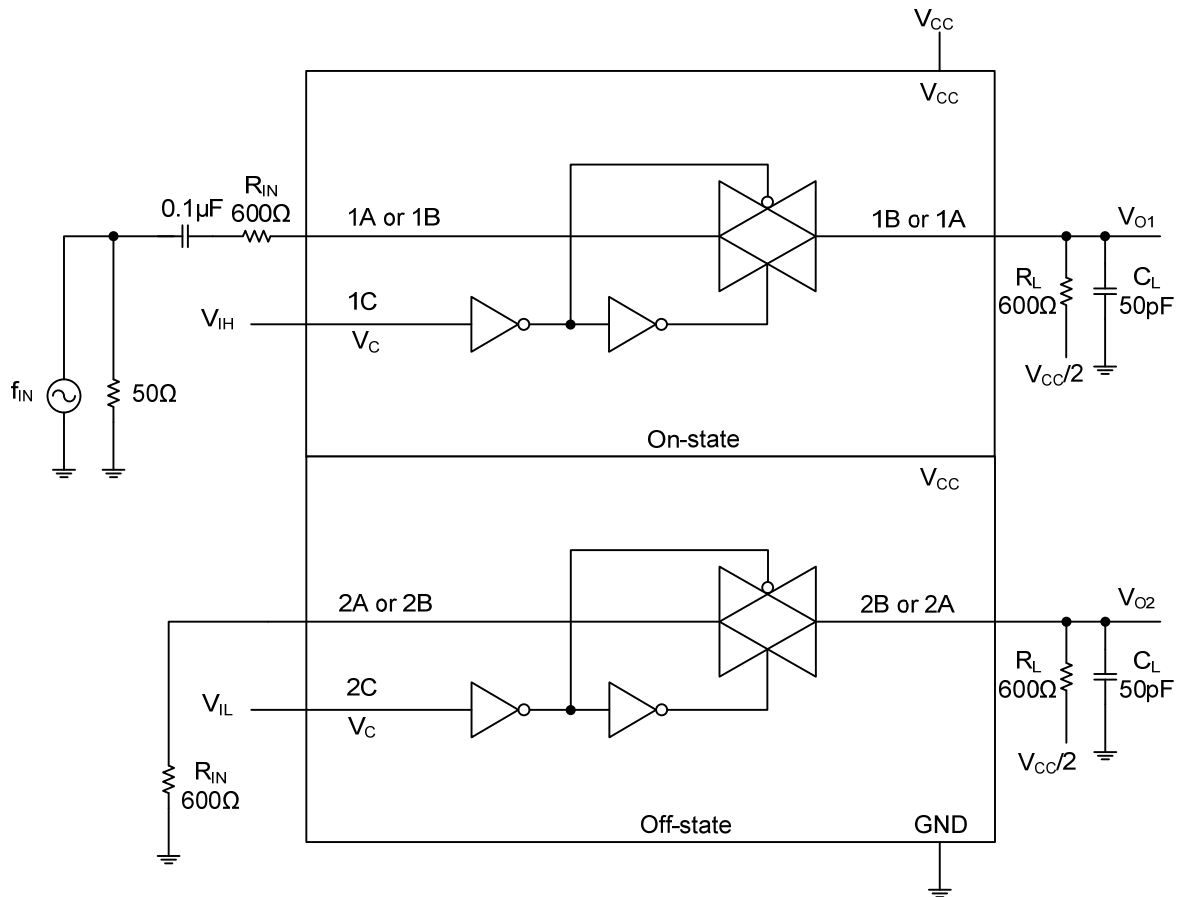

$$20 \log_{10}(V_{O2}/V_{I1}) \text{ or } 20 \log_{10}(V_{O1}/V_{I2})$$

Fig.6 Crosstalk (between switches)

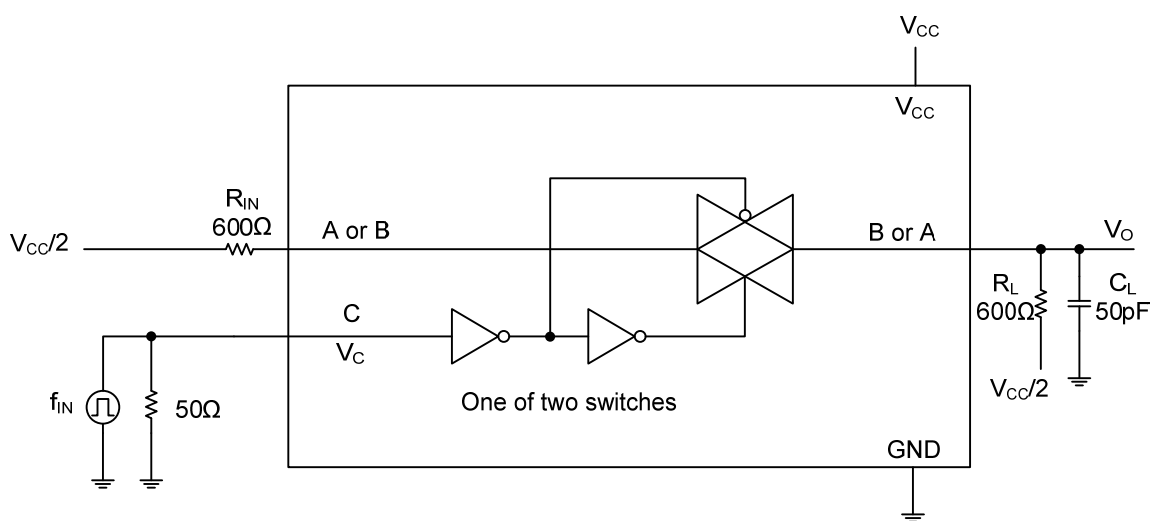

Fig.7 Crosstalk (control input, switch output)

■ PARAMETER MEASUREMENT (Cont.)

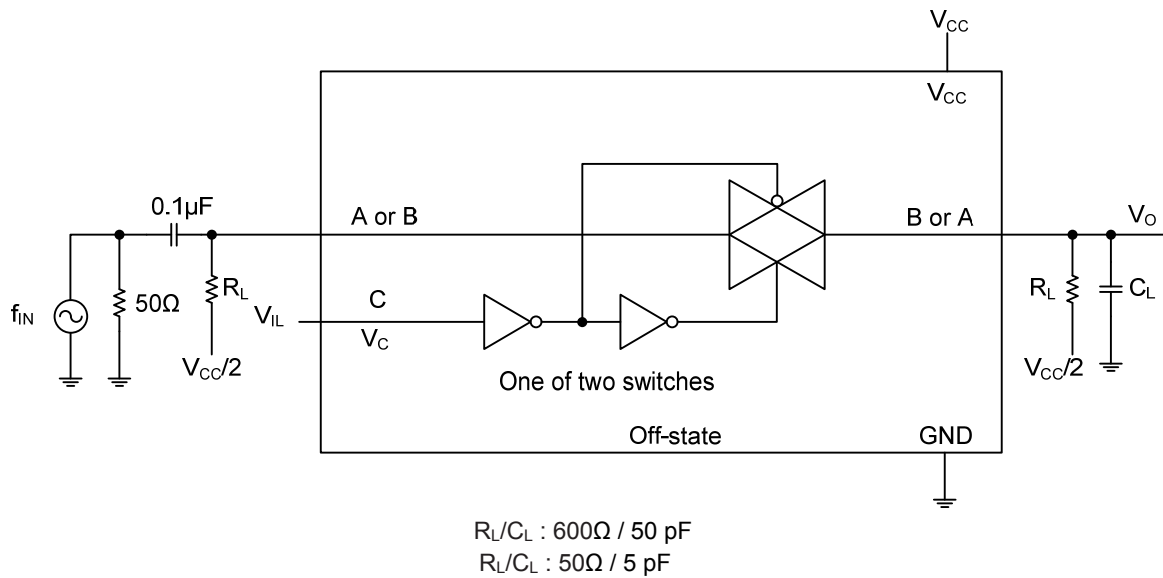

Fig.8 Feedthrough (switch off)

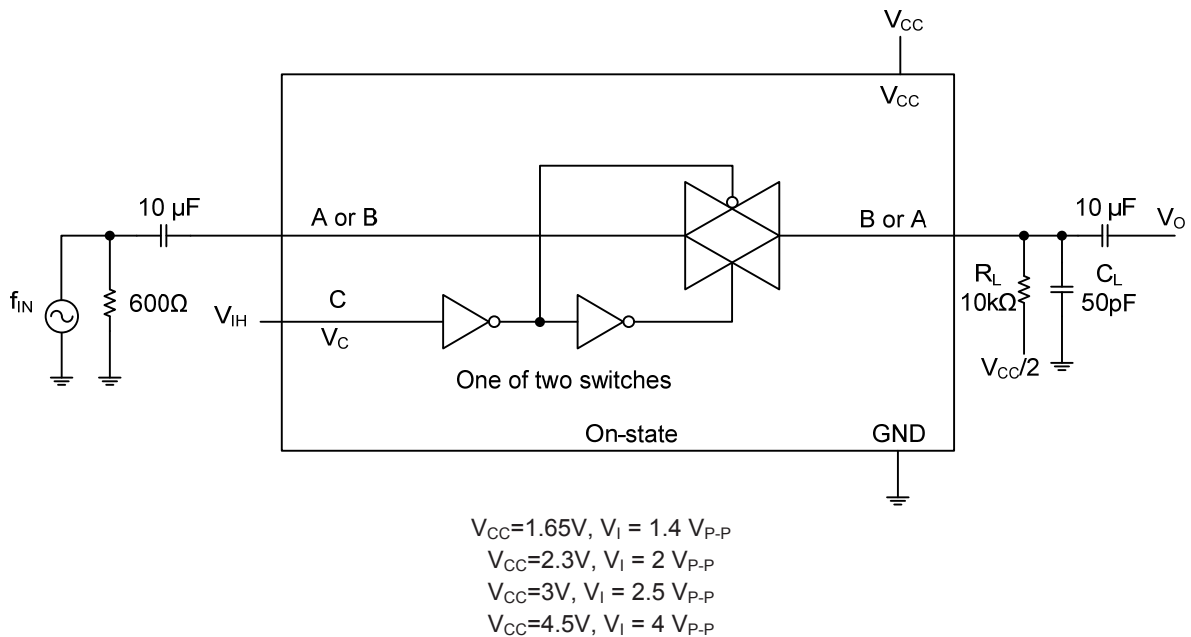

Fig.9 Sine-wave distortion

UTC assumes no responsibility for equipment failures that result from using products at values that exceed, even momentarily, rated values (such as maximum ratings, operating condition ranges, or other parameters) listed in products specifications of any and all UTC products described or contained herein. UTC products are not designed for use in life support appliances, devices or systems where malfunction of these products can be reasonably expected to result in personal injury. Reproduction in whole or in part is prohibited without the prior written consent of the copyright owner. UTC reserves the right to make changes to information published in this document, including without limitation specifications and product descriptions, at any time and without notice. This document supersedes and replaces all information supplied prior to the publication hereof.