



U74LVC2G14

CMOS IC

DUAL SCHMITT-TRIGGER INVERTER WITH 5V TOLERANT INPUT

DESCRIPTION

The UTC **U74LVC2G14** is a high-performance, low-power, low-voltage, Si-gate CMOS device which provides two inverters with Schmitt trigger action. It is capable of transforming slowly changed input signals into sharply defined, jitter-free output signals.

FEATURES

- * Operate From 1.65V to 5.5V
- * 5V Tolerant Input/Output for Interfacing with 5V logic
- * ±24mA Output Drive ($V_{CC} = 3.3V$)
- * CMOS Low-Power Consumption and High Noise Immunity

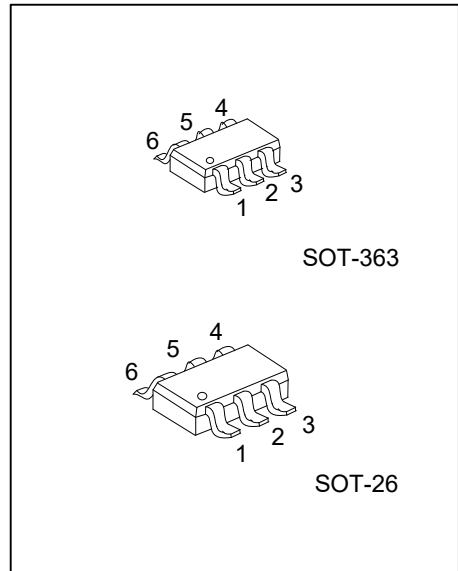

ORDERING INFORMATION

Ordering Number		Package	Packing
U74LVC2G14L-AL6-R	U74LVC2G14G-AL6-R	SOT-363	Tape Reel
U74LVC2G14L-AG6-R	U74LVC2G14G-AG6-R	SOT-26	Tape Reel

<p>U74LVC2G14G-AL6-R</p> <p>(1) Packing Type (2) Package Type (3) Green Package</p>	<p>(1) R: Tape Reel (2) AL6: SOT-363, AG6: SOT-26 (3) G: Halogen Free and Lead Free, L: Lead Free</p>
---	---

MARKING

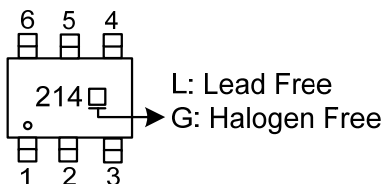

■ PIN CONFIGURATION

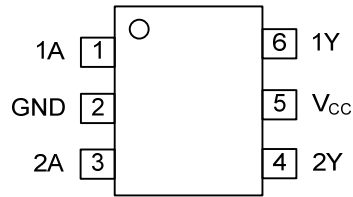

■ FUNCTION TABLE

INPUT(A)	OUTPUT(Y)
L	H
H	L

H=High level

L=Low Level

■ LOGIC SYMBOL

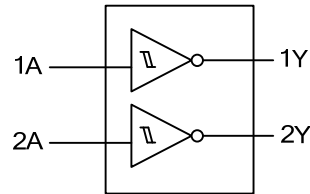

■ FUNCTIONAL DIAGRAM

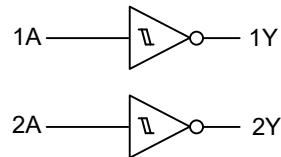

■ ABSOLUTE MAXIMUM RATING (Unless otherwise specified)

PARAMETER		SYMBOL	RATINGS	UNIT
Supply Voltage		V_{CC}	-0.5 ~ +6.5	V
Input Voltage		V_{IN}	-0.5 ~ +6.5	V
Output Voltage	High-impedance	V_{OUT}	-0.5 ~ 6.5	V
	Power-off			
	High State		-0.5 ~ $V_{CC}+0.5$	V
	Low State			
V_{CC} or GND Current		I_{CC}	±100	mA
Continuous Output Current		I_O	±50	mA
Input Clamp Current		I_{IK}	-50	mA
Output Clamp Current		I_{OK}	-50	mA
Storage Temperature		T_{STG}	-65 ~ + 150	°C

Note: Absolute maximum ratings are those values beyond which the device could be permanently damaged. Absolute maximum ratings are stress ratings only and functional device operation is not implied.

■ THERMAL DATA

PARAMETER		SYMBOL	RATINGS	UNIT
Junction to Ambient	SOT-363	θ_{JA}	350	°C/W
	SOT-26		230	°C/W

■ RECOMMENDED OPERATING CONDITIONS (Unless otherwise specified)

PARAMETER	SYMBOL	TEST CONDITIONS	MIN	TYP	MAX	UNIT
Supply Voltage	V_{CC}		1.65		5.5	V
Control Input Voltage	V_{IN}		0		5.5	V
Output Voltage	V_{OUT}	High or low state	0		V_{CC}	V
High Level Output Current	I_{OH}	$V_{CC} = 1.65V$			-4	mA
		$V_{CC} = 2.3V$			-8	mA
		$V_{CC} = 3V$			-16	mA
		$V_{CC} = 3V$			-24	mA
		$V_{CC} = 4.5V$			-32	mA
Low Level Output Current	I_{OL}	$V_{CC} = 1.65V$			4	mA
		$V_{CC} = 2.3V$			8	mA
		$V_{CC} = 3V$			16	mA
		$V_{CC} = 3V$			24	mA
		$V_{CC} = 4.5V$			32	mA
Operating Temperature	T_A		-40		+125	°C

■ ELECTRICAL CHARACTERISTICS (Unless otherwise specified)

PARAMETER	SYMBOL	TEST CONDITIONS	T _A =25°C			T _A =-40~+125°C			UNIT
			MIN	TYP	MAX	MIN	TYP	MAX	
Positive-Going Input Threshold Voltage	V _{T+}	V _{CC} =1.65V	0.7	1.24	1.5	0.7		1.7	V
		V _{CC} =2.3V	1.0	1.54	1.8	1.0		2.0	V
		V _{CC} =3V	1.3	1.86	2.2	1.3		2.4	V
		V _{CC} =4.5V	1.9	2.59	3.1	1.9		3.3	V
		V _{CC} =5.5V	2.2	3.08	3.7	2.2		3.8	V
Negative-Going Input Threshold Voltage	V _{T-}	V _{CC} =1.65V	0.25	0.61	0.9	0.25		1.1	V
		V _{CC} =2.3V	0.4	0.82	1.15	0.4		1.35	V
		V _{CC} =3V	0.6	1.15	1.5	0.6		1.7	V
		V _{CC} =4.5V	1.0	1.73	2.0	1.0		2.2	V
		V _{CC} =5.5V	1.2	2.13	2.5	1.2		2.5	V
Hysteresis Voltage (V _{T+} - V _{T-})	ΔV _T	V _{CC} =1.65V	0.15	0.67	1.0	0.15		1.2	V
		V _{CC} =2.3V	0.25	0.72	1.1	0.25		1.3	V
		V _{CC} =3V	0.4	0.73	1.2	0.4		1.4	V
		V _{CC} =4.5V	0.6	0.92	1.5	0.6		1.7	V
		V _{CC} =5.5V	0.7	1.02	1.7	0.7		1.9	V
High-Level Output Voltage	V _{OH}	V _{CC} =1.65~5.5V, I _{OH} =-100uA	V _{CC} -0.1			V _{CC} -0.1			V
		V _{CC} =1.65V, I _{OH} =-4mA	1.20			0.95			V
		V _{CC} =2.3V, I _{OH} =-8mA	1.90			1.7			V
		V _{CC} =3V, I _{OH} =-16mA	2.20			1.9			V
		V _{CC} =3V, I _{OH} =-24mA	2.30			2.0			V
		V _{CC} =4.5V, I _{OH} =-32mA	3.80			3.4			V
Low-Level Output Voltage	V _{OL}	V _{CC} =1.65~5.5V, I _{OL} =100uA			0.10			0.1	V
		V _{CC} =1.65V, I _{OL} =4mA			0.45			0.7	V
		V _{CC} =2.3V, I _{OL} =8mA			0.30			0.45	V
		V _{CC} =3V, I _{OL} =16mA			0.40			0.6	V
		V _{CC} =3V, I _{OL} =24mA			0.55			0.8	V
		V _{CC} =4.5V, I _{OL} =32mA			0.55			0.8	V
Input Leakage Current	I _{I(LEAK)}	V _{CC} =0V to 5.5V, V _{IN} =0 or 5.5V			±5			±5	μA
Power OFF Leakage Current	I _{OFF}	V _{CC} =0V, V _{IN} or V _{OUT} =5.5V,			±10			±10	μA
Quiescent Supply Current	I _Q	V _{CC} =1.65V to 5.5V, I _{OUT} =0 V _{IN} =5.5V or GND		0.1	10			10	μA
Additional Quiescent Supply Current Per Pin	ΔI _Q	V _{CC} =3V to 5.5V One input at V _{CC} -0.6V, Other inputs at V _{CC} or GND, I _{OUT} =0			500			500	μA

■ SWITCHING CHARACTERISTICS (Unless otherwise specified)

(see TEST CIRCUIT AND WAVEFORMS)

PARAMETER	SYMBOL	TEST CONDITIONS	T _A =25°C			T _A =-40~+125°C			UNIT
			MIN	TYP	MAX	MIN	TYP	MAX	
Propagation Delay from Input (nA) to Output(nY)	t _{PLH} / t _{PHL}	V _{CC} = 1.8V±0.15V, V _{IN} =V _{CC} C _L =30pF, R _L =1KΩ	3.9		13	1.0		15	ns
		V _{CC} =2.5V±0.2V, V _{IN} =V _{CC} C _L =30pF, R _L =500Ω	1.9		6.5	1.0		8.5	ns
		V _{CC} = 3.3V±0.3V, V _{IN} =3V C _L =50pF, R _L =500Ω	2.0		6.1	1.0		8.1	ns
		V _{CC} =5V±0.5V, V _{IN} =V _{CC} C _L =50pF, R _L =500Ω	1.5		5	0.5		6.0	ns

■ OPERATING CHARACTERISTICS (Unless otherwise specified)

PARAMETER	SYMBOL	TEST CONDITIONS	MIN	TYP	MAX	UNIT
Input Capacitance	C _{IN}	V _{CC} =3.3V, V _{IN} =V _{CC} or GND		4		pF
Power Dissipation Capacitance	C _{PD}	V _{CC} =1.8V, f=10MHz		16		pF
		V _{CC} =2.5V, f=10MHz		17		pF
		V _{CC} =3.3V, f=10MHz		18		pF
		V _{CC} =5V, f=10MHz		21		pF

■ TEST CIRCUITS AND WAVEFORMS

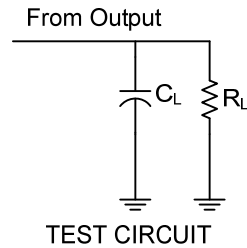

V _{CC}	Inputs		V _M	C _L	R _L
	V _{IN}	t _R , t _F			
1.8V±0.15V	V _{CC}	≤2ns	V _{CC} /2	30pF	1kΩ
2.5V±0.2V	V _{CC}	≤2ns	V _{CC} /2	30pF	500Ω
3.3V±0.3V	3V	≤2.5ns	1.5V	50pF	500Ω
5V±0.5V	V _{CC}	≤2.5ns	V _{CC} /2	50pF	500Ω

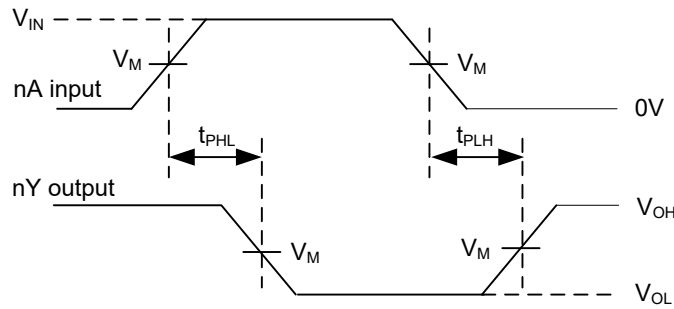

- Note: 1. C_L includes probe and jig capacitance.
 2. All input pulses are supplied by generators having the following characteristics:
 PRR≤1MHz, Z_O = 50Ω: t_R≤2ns, t_F ≤2ns (V_{CC}=1.8V±0.15V and V_{CC}=2.5V±0.2V)
 t_R ≤2.5ns, t_F ≤2.5ns (V_{CC} =3.3V±0.3V and V_{CC}=5V±0.5V)

UTC assumes no responsibility for equipment failures that result from using products at values that exceed, even momentarily, rated values (such as maximum ratings, operating condition ranges, or other parameters) listed in products specifications of any and all UTC products described or contained herein. UTC products are not designed for use in life support appliances, devices or systems where malfunction of these products can be reasonably expected to result in personal injury. Reproduction in whole or in part is prohibited without the prior written consent of the copyright owner. UTC reserves the right to make changes to information published in this document, including without limitation specifications and product descriptions, at any time and without notice. This document supersedes and replaces all information supplied prior to the publication hereof.