



## U74AC04

CMOS IC

### HEX INVERTERS

#### DESCRIPTION

The **U74AC04** contains six independent inverters and performs the Boolean function  $Y = \overline{A}$  in positive logic circuit.

#### FEATURES

- \* Operation Voltage Range:  $V_{CC} = 2V$  to  $6V$
- \* High Speed:  $t_{PD} = 4ns$  (TYP.) at  $V_{CC} = 5V$
- \* Low Input Current:  $I_{IN} = 0.1mA$  (Max.) at  $T_A = 25^\circ C$
- \* Low Power Dissipation:  $I_{CC} = 2\mu A$  (Max.) at  $T_A = 25^\circ C$

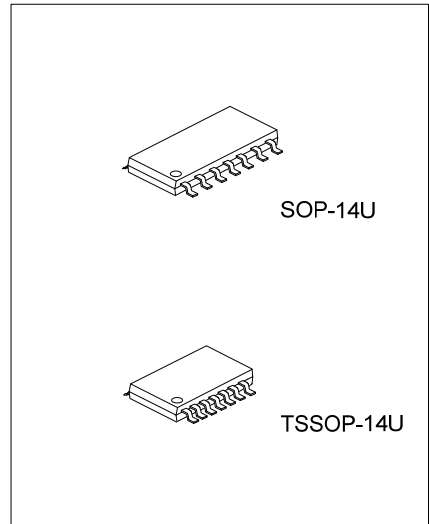

#### ORDERING INFORMATION

Ordering Number		Package	Packing
Lead Free	Halogen Free		
U74AC04L-UEA-R	U74AC04G-UEA-R	SOP-14U	Tape Reel
U74AC04L-UEB-R	U74AC04G-UEB-R	TSSOP-14U	Tape Reel

<p>U74AC04G-UEA-R</p> <p>(1) Packing Type</p> <p>(2) Package Type</p> <p>(3) Green Package</p>	<p>(1) R: Tape Reel</p> <p>(2) UEA: SOP-14U, UEB: TSSOP-14U</p> <p>(3) G: Halogen Free and Lead Free, L: Lead Free</p>
--	--

#### MARKING

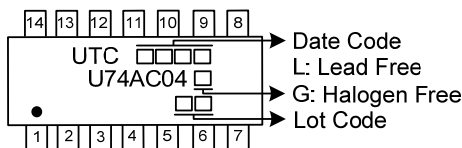

## ■ PIN CONFIGURATION

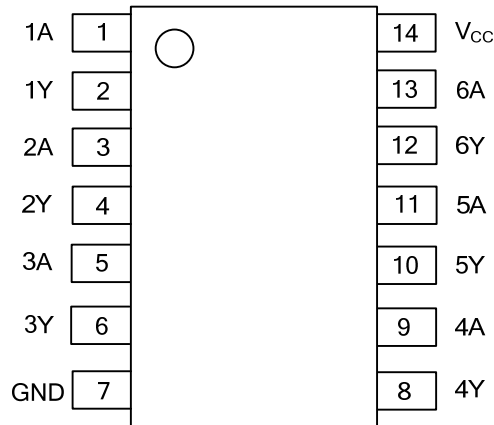

## ■ FUNCTION TABLE (Each Inverter)

INPUT(A)	OUTPUT(Y)
H	L
L	H

Note: H: HIGH voltage level; L: LOW voltage level.

## ■ LOGIC DIAGRAM (Each Inverter)

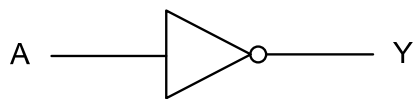

Logic Symbol

### ■ ABSOLUTE MAXIMUM RATING

PARAMETER	SYMBOL	RATINGS	UNIT
Supply Voltage	$V_{CC}$	-0.5 ~ +7	V
Input Voltage	$V_{IN}$	-0.5 ~ $V_{CC}+0.5$	V
Output Voltage	$V_{OUT}$	-0.5 ~ $V_{CC}+0.5$	V
$V_{CC}$ or GND Current	$I_{CC}$	±200	mA
Continuous Output Current ( $V_{OUT}=0$ to $V_{CC}$ )	$I_{OUT}$	±50	mA
Input Clamp Current ( $V_{IN}<0$ or $V_{IN}>V_{CC}$ )	$I_{IK}$	±20	mA
Output Clamp Current ( $V_{OUT}<0$ or $V_{OUT}>V_{CC}$ )	$I_{OK}$	±20	mA
Storage Temperature	$T_{STG}$	-65 ~ +150	°C

Note: Absolute maximum ratings are those values beyond which the device could be permanently damaged. Absolute maximum ratings are stress ratings only and functional device operation is not implied.

### ■ RECOMMENDED OPERATING CONDITIONS

PARAMETER	SYMBOL	TEST CONDITIONS	MIN	TYP	MAX	UNIT
Supply Voltage	$V_{CC}$		2		6	V
Input Voltage	$V_{IN}$		0		$V_{CC}$	V
Output Voltage	$V_{OUT}$		0		$V_{CC}$	V
High-Level Output Current	$I_{OH}$	$V_{CC}=3V$			-12	mA
		$V_{CC}=4.5V$			-24	mA
		$V_{CC}=5.5V$			-24	mA
Low-Level Output Current	$I_{OL}$	$V_{CC}=3V$			12	mA
		$V_{CC}=4.5V$			24	mA
		$V_{CC}=5.5V$			24	mA
Input Transition Rise or Fall Rate	$\Delta t/\Delta v$		0		8	ns/V
Operating Temperature	$T_A$		-40		+125	°C

### ■ THERMAL DATA

PARAMETER	SYMBOL	RATINGS	UNIT
Junction to Case	SOP-14U	95	°C/W
	TSSOP-14U	120	°C/W

■ ELECTRICAL CHARACTERISTICS (T<sub>A</sub>=25°C , unless otherwise specified)

PARAMETER	SYMBOL	TEST CONDITIONS	MIN	TYP	MAX	UNIT	
High-level Input Voltage	V <sub>IH</sub>	V <sub>CC</sub> =3V	2.1			V	
		V <sub>CC</sub> =4.5V	3.15			V	
		V <sub>CC</sub> =5.5V	3.85			V	
Low-level Input Voltage	V <sub>IL</sub>	V <sub>CC</sub> =3V			0.9	V	
		V <sub>CC</sub> =4.5V			1.35	V	
		V <sub>CC</sub> =5.5V			1.65	V	
High-Level Output Voltage	V <sub>OH</sub>	V <sub>CC</sub> =3V	I <sub>OH</sub> =-50μA	2.9	2.99		V
		V <sub>CC</sub> =4.5V		4.4	4.49		V
		V <sub>CC</sub> =5.5V		5.4	5.49		V
		V <sub>CC</sub> =3V	I <sub>OH</sub> =-12mA	2.56			V
		V <sub>CC</sub> =4.5V		3.86			V
		V <sub>CC</sub> =5.5V		4.86			V
Low-Level Output Voltage	V <sub>OL</sub>	V <sub>CC</sub> =3V	I <sub>OL</sub> =50μA			0.1	V
		V <sub>CC</sub> =4.5V				0.1	V
		V <sub>CC</sub> =5.5V				0.1	V
		V <sub>CC</sub> =3V	I <sub>OL</sub> =12mA			0.36	V
		V <sub>CC</sub> =4.5V				0.36	V
		V <sub>CC</sub> =5.5V				0.36	V
Input Leakage Current	I <sub>I(LEAK)</sub>	V <sub>IN</sub> = V <sub>CC</sub> or GND, V <sub>CC</sub> =5.5V			±0.1	μA	
Quiescent Supply Current	I <sub>Q</sub>	V <sub>IN</sub> = V <sub>CC</sub> or GND, I <sub>OUT</sub> =0 V <sub>CC</sub> =5.5V			2	μA	
Input Capacitance	C <sub>IN</sub>	V <sub>IN</sub> = V <sub>CC</sub> or GND		2.8		pF	

■ SWITCHING CHARACTERISTICS (T<sub>A</sub>=25°C , unless otherwise specified)

PARAMETER	SYMBOL	TEST CONDITIONS	MIN	TYP	MAX	UNIT
Propagation delay from input (nA) to output(nY)	t <sub>PLH</sub>	V <sub>CC</sub> =3.3±0.3V, C <sub>L</sub> =50pF, R <sub>L</sub> =500Ω	1.5	4.5	9	ns
	t <sub>PHL</sub>		1.5	4.5	8.5	ns
	t <sub>PLH</sub>	V <sub>CC</sub> =5±0.5V, C <sub>L</sub> =50pF, R <sub>L</sub> =500Ω	1.5	4	7	ns
	t <sub>PHL</sub>		1.5	3.5	6.5	ns

■ OPERATING CHARACTERISTICS (T<sub>A</sub>=25°C , unless otherwise specified)

PARAMETER	SYMBOL	TEST CONDITIONS	MIN	TYP	MAX	UNIT
Power Dissipation Capacitance	C <sub>PD</sub>	C <sub>L</sub> =50pF, f=10MHz		45		pF

■ TEST CIRCUIT AND WAVEFORMS

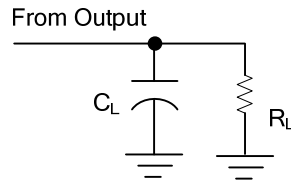

TEST CIRCUIT

V <sub>CC</sub>	INPUTS		V <sub>M</sub>	C <sub>L</sub>	R <sub>L</sub>
	V <sub>IN</sub>	t <sub>R</sub> , t <sub>F</sub>			
3.3V±0.3V	V <sub>CC</sub>	≤2.5ns	V <sub>CC</sub> /2	50pF	500Ω
5V±0.5V	V <sub>CC</sub>	≤2.5ns	V <sub>CC</sub> /2	50pF	500Ω

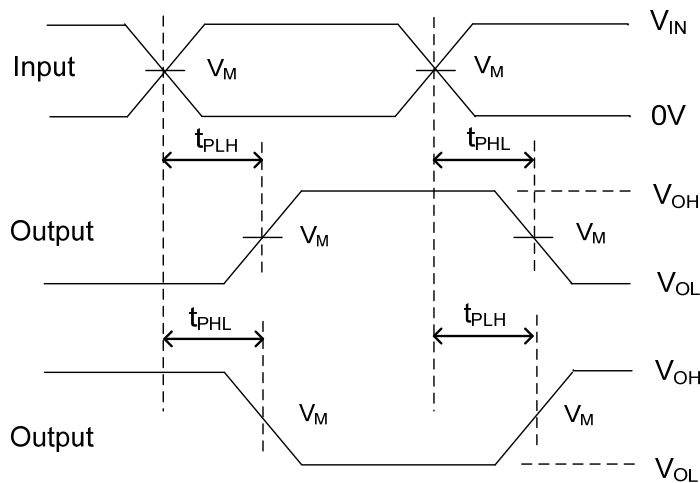

VOLTAGE WAVEFORMS

- Notes: 1. C<sub>L</sub> includes probe and jig capacitance  
 2. All input pulses are supplied by generators having the following characteristics: PRR ≤1MHz, Z<sub>0</sub> = 50Ω.

UTC assumes no responsibility for equipment failures that result from using products at values that exceed, even momentarily, rated values (such as maximum ratings, operating condition ranges, or other parameters) listed in products specifications of any and all UTC products described or contained herein. UTC products are not designed for use in life support appliances, devices or systems where malfunction of these products can be reasonably expected to result in personal injury. Reproduction in whole or in part is prohibited without the prior written consent of the copyright owner. UTC reserves the right to make changes to information published in this document, including without limitation specifications and product descriptions, at any time and without notice. This document supersedes and replaces all information supplied prior to the publication hereof.