



U74HC245

CMOS IC

OCTAL BUS TRANSCEIVERS WITH 3-STATE OUTPUTS

DESCRIPTION

The **U74HC245** is designed for the asynchronous communication between data buses. While the direction-control(DIR) is high, data transmits from the A bus to the B bus. Data transmits from the B bus to the A bus if DIR is low. The output-enable(\overline{OE}) will isolate the device from the buses when high voltage is applied on it.

FEATURES

- * Operate from 2V to 6V
- * Max t_{PD} is 18ns at 6V

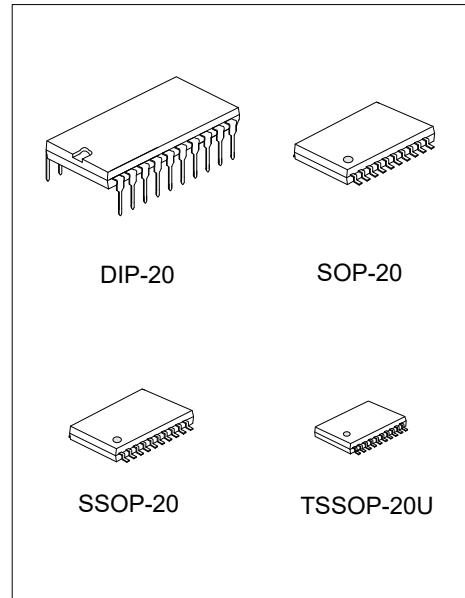

ORDERING INFORMATION

Ordering Number		Package	Packing
Lead Free	Halogen Free		
U74HC245L-D20-T	U74HC245G-D20-T	DIP-20	Tube
U74HC245L-S20-R	U74HC245G-S20-R	SOP-20	Tape Reel
U74HC245L-R20-R	U74HC245G-R20-R	SSOP-20	Tape Reel
U74HC245L-ULA-R	U74HC245G-ULA-R	TSSOP-20U	Tape Reel

<p>U74HC245G-D20-T</p> <p>(1) Packing Type (2) Package Type (3) Green Package</p>	<p>(1) T: Tube, R: Tape Reel (2) D20: DIP-20, S20: SOP-20, R20: SSOP-20, ULA: TSSOP-20U (3) G: Halogen Free and Lead Free, L: Lead Free</p>
---	---

MARKING

DIP-20	SOP-20 / SSOP-20 / TSSOP-20U
<p>UTC □□□□ → Date Code L: Lead Free G: Halogen Free □□□ → Lot Code</p>	<p>UTC □□□□ → Date Code L: Lead Free G: Halogen Free □□□ → Lot Code</p>

■ PIN CONFIGURATION

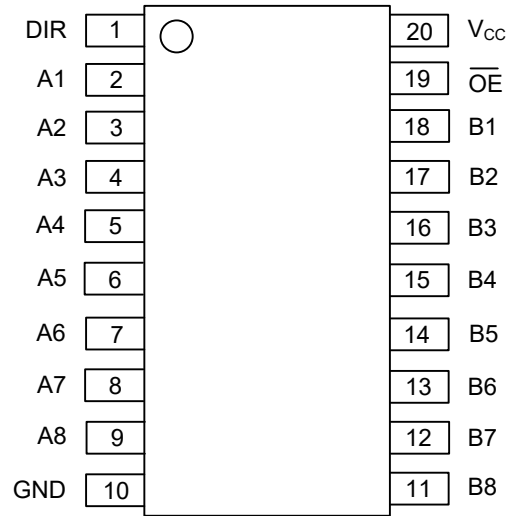

■ FUNCTION TABLE

INPUT		FUNCTION
\overline{OE}	DIR	
H	X	Isolation
L	H	Transmit data from A bus to B bus
L	L	Transmit data from B bus to A bus

Note: H: HIGH voltage level; L: LOW voltage level.

■ LOGIC DIAGRAM

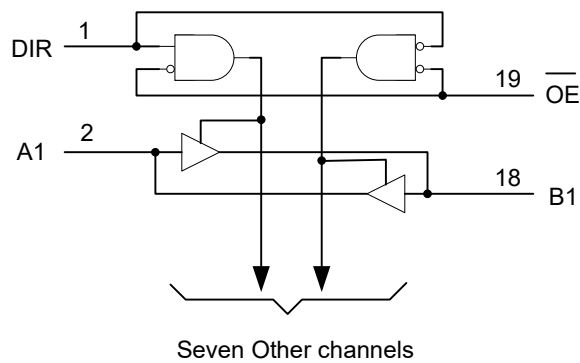

■ ABSOLUTE MAXIMUM RATING (T_A=25°C, unless otherwise specified)

PARAMETER	SYMBOL	RATINGS	UNIT
Supply Voltage	V _{CC}	-0.5 ~ 7.0	V
Input Clamp Current (V _{IN} < 0V or V _{IN} > V _{CC})	I _{IK}	±20	mA
Output Clamp Current (V _{OUT} < 0V or V _{OUT} > V _{CC})	I _{OK}	±20	mA
Output Current	I _{OUT}	±35	mA
V _{CC} or GND Current	I _{CC}	±70	mA
Storage Temperature	T _{STG}	-65 ~ +150	°C

Note: Absolute maximum ratings are those values beyond which the device could be permanently damaged. Absolute maximum ratings are stress ratings only and functional device operation is not implied.

■ THERMAL DATA

PARAMETER	SYMBOL	RATINGS	UNIT
Junction to Ambient	DIP-20	65	°C/W
	SOP-20	85	°C/W
	SSOP-20	105	°C/W
	TSSOP-20U	110	°C/W

■ RECOMMENDED OPERATING CONDITIONS

PARAMETER	SYMBOL	TEST CONDITIONS	MIN	TYP	MAX	UNIT
Supply Voltage	V _{CC}		2	5	6	V
Input Voltage	V _{IN}		0		V _{CC}	V
Output Voltage	V _{OUT}		0		V _{CC}	V
Input Transition Rise and Fall Time	t _R / t _F	V _{CC} = 2V			1000	ns
		V _{CC} = 4.5V			500	ns
		V _{CC} = 6V			400	ns
Ambient Operating Temperature	T _A		-40		+125	°C

■ ELECTRICAL CHARACTERISTICS (Unless otherwise specified)

PARAMETER	SYMBOL	TEST CONDITIONS	T _A =25°C			T _A =-40~+125°C			UNIT
			MIN	TYP	MAX	MIN	TYP	MAX	
High-level input voltage	V _{IH}	V _{CC} =2V	1.5			1.5			V
		V _{CC} =4.5V	3.15			3.15			V
		V _{CC} =6V	4.2			4.2			V
Low-level output voltage	V _{IL}	V _{CC} =2V			0.5			0.5	V
		V _{CC} =4.5V			1.35			1.35	V
		V _{CC} =6V			1.8			1.8	V
High-Level Output Voltage	V _{OH}	V _{CC} =2V, I _{OH} =-20μA	1.9	1.998		1.9			V
		V _{CC} =4.5V, I _{OH} =-20μA	4.4	4.499		4.4			V
		V _{CC} =6V, I _{OH} =-20μA	5.9	5.999		5.9			V
		V _{CC} =4.5V, I _{OH} =-6mA	3.98	4.3		3.7			V
		V _{CC} =6V, I _{OH} =-7.8mA	5.48	5.8		5.2			V
Low-Level Output Voltage	V _{OL}	V _{CC} =2V, I _{OL} =20μA		0.002	0.1			0.1	V
		V _{CC} =4.5V, I _{OL} =20μA		0.001	0.1			0.1	V
		V _{CC} =6V, I _{OL} =20μA		0.001	0.1			0.1	V
		V _{CC} =4.5V, I _{OL} =6mA		0.17	0.26			0.4	V
		V _{CC} =6V, I _{OL} =7.8mA		0.15	0.26			0.4	V
Input Current of DIR or \overline{OE}	I _{I(LEAK)}	V _{CC} =6V, V _{IN} =V _{CC} or GND		±0.1	±100			±1000	nA
Output OFF-state current	I _{OZ}	V _{CC} =6V, V _{OUT} =V _{CC} or GND		±0.01	±0.5			±10	μA
Quiescent Supply Current	I _Q	V _{CC} =6V, V _{IN} =V _{CC} or GND, I _{OUT} =0			8			160	μA

■ SWITCHING CHARACTERISTICS (C_L=50pF, R_L=1kΩ, unless otherwise specified)

PARAMETER	SYMBOL	TEST CONDITIONS	T _A =25°C			T _A =-40~+125°C			UNIT
			MIN	TYP	MAX	MIN	TYP	MAX	
Propagation delay from input (A or B) to output (B or A)	t _{PD} (t _{PLH} /t _{PHL})	V _{CC} =2V		22	105	1		135	ns
		V _{CC} =4.5V		14	21	1		27	ns
		V _{CC} =6V		12	18	1		23	ns
3-state output enable time from input (\overline{OE}) to output (A or B)	t _{EN} (t _{PZL} /t _{PZH})	V _{CC} =2V		32	230	1		290	ns
		V _{CC} =4.5V		23	46	1		58	ns
		V _{CC} =6V		10	39	1		49	ns
3-state output disable time from input (\overline{OE}) to output (A or B)	t _{DIS} (t _{PLZ} /t _{PHZ})	V _{CC} =2V		25	200	1		250	ns
		V _{CC} =4.5V		17	40	1		50	ns
		V _{CC} =6V		10	34	1		43	ns
Output transition time (A or B)	t _T (t _R /t _F)	V _{CC} =2V		20	60	1		90	ns
		V _{CC} =4.5V		8	12	1		18	ns
		V _{CC} =6V		6	10	1		15	ns

■ OPERATING CHARACTERISTICS

PARAMETER	SYMBOL	TEST CONDITIONS	MIN	TYP	MAX	UNIT
Input Capacitance of DIR or \overline{OE}	C _{IN}	V _{CC} =6V, V _{IN} =V _{CC} or GND		3	10	pF
Power Dissipation Capacitance	C _{PD}	No load		40		pF

■ TEST CIRCUIT AND WAVEFORMS

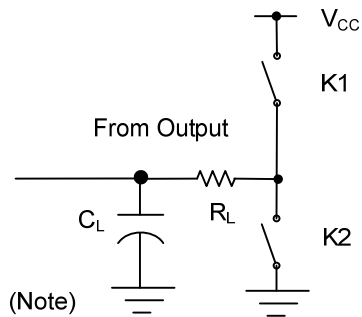

TEST	K1	K2
t_{PLH}/t_{PHL}	Open	Open
t_{PHZ}/t_{PZH}	Open	Close
t_{PLZ}/t_{PZL}	Close	Open

Note: C_L includes probe and jig capacitance.

$$P_{RR} \leq 1\text{MHz}, Z_0 = 50\Omega, t_r \leq 6\text{ns}, t_f \leq 6\text{ns}$$

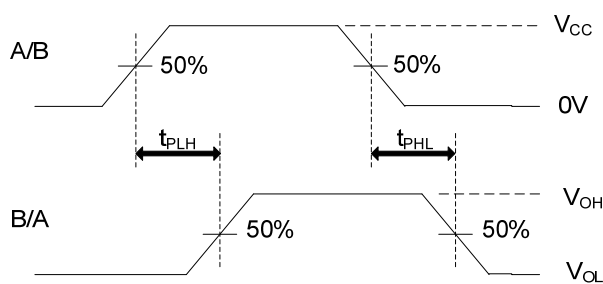

Propagation Delay Times

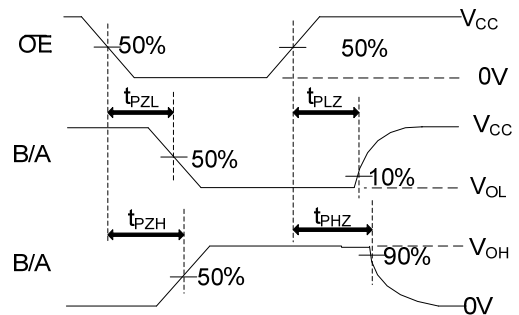

Enable and Disable Times

■ TYPICAL CHARACTERISTICS

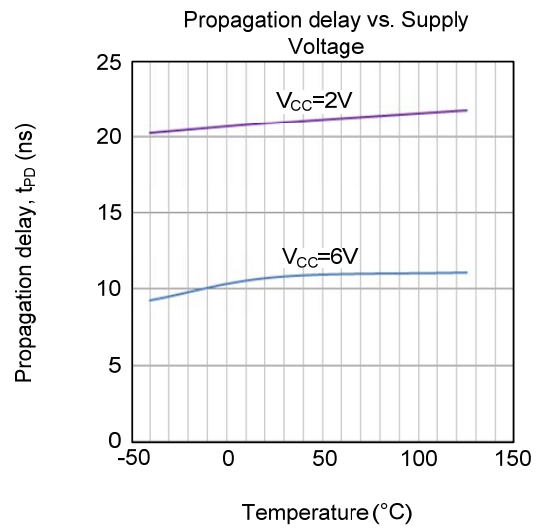
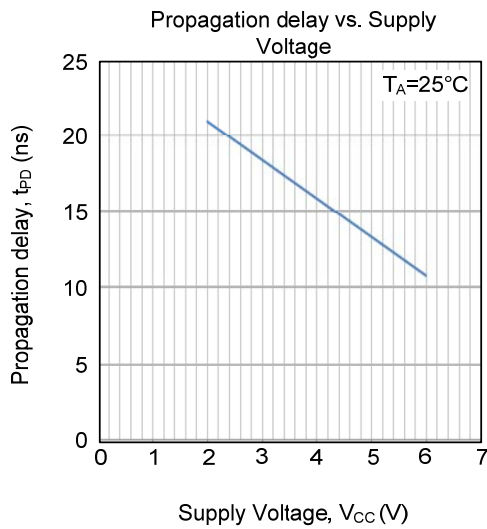

UTC assumes no responsibility for equipment failures that result from using products at values that exceed, even momentarily, rated values (such as maximum ratings, operating condition ranges, or other parameters) listed in products specifications of any and all UTC products described or contained herein. UTC products are not designed for use in life support appliances, devices or systems where malfunction of these products can be reasonably expected to result in personal injury. Reproduction in whole or in part is prohibited without the prior written consent of the copyright owner. UTC reserves the right to make changes to information published in this document, including without limitation specifications and product descriptions, at any time and without notice. This document supersedes and replaces all information supplied prior to the publication hereof.