



U74HC164

CMOS IC

8-BIT SERIAL-IN AND PARALLEL-OUT SHIFT REGISTER

DESCRIPTION

The **U74HC164** is an 8-bit edge-triggered shift registers with serial input and parallel output. A LOW-to-HIGH transition on the CP will shifts the data one place to the right which is the logical AND of DSA and DSB.

A Low level on the \overline{MR} will clear the registers asynchronously and force the outputs LOW.

FEATURES

- * Operation Voltage Range: 2~6V
- * Asynchronous Reset Input

ORDERING INFORMATION

Ordering Number		Package	Packing
Lead Free	Halogen Free		
U74HC164L-D14-T	U74HC164G-D14-T	DIP-14	Tube
U74HC164L-UEA-R	U74HC164G-UEA-R	SOP-14U	Tape Reel
U74HC164L-UEB-R	U74HC164G-UEB-R	TSSOP-14U	Tape Reel

	<p>(1) T: Tube, R: Tape Reel</p> <p>(2) D14: DIP-14, UEA: SOP-14U, UEB: TSSOP-14U</p> <p>(3) G: Halogen Free and Lead Free, L: Lead Free</p>
--	--

MARKING

DIP-14	SOP-14U / TSSOP-14U

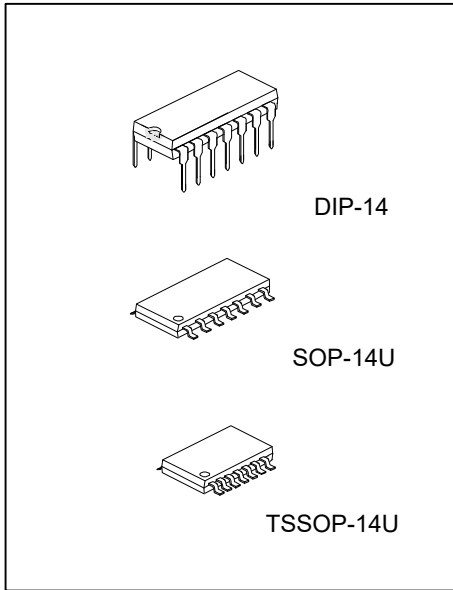

■ PIN CONFIGURATION

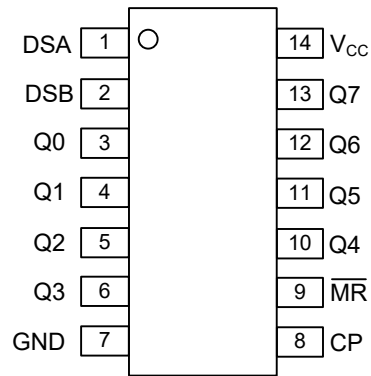

■ FUNCTION TABLE

INPUT				OUTPUT	
\overline{MR}	CP	DSA	DSB	Q0	Q1 to Q7
L	X	X	X	L	L to L
H	L	X	X	Q0	Q1 to Q7
H	↑	H	L	L	Q0 to Q6
H	↑	H	H	H	Q0 to Q6
H	↑	L	H	L	Q0 to Q6
H	↑	L	L	L	Q0 to Q6

■ FUNCTIONAL DIAGRAM

Logic Diagram

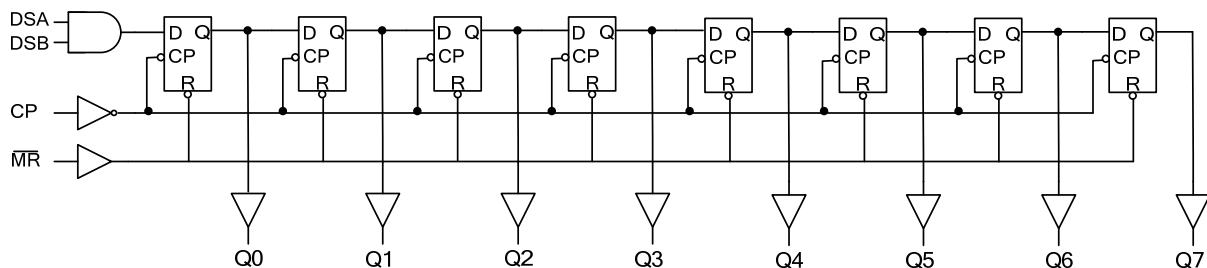

IEC Logic Symbol

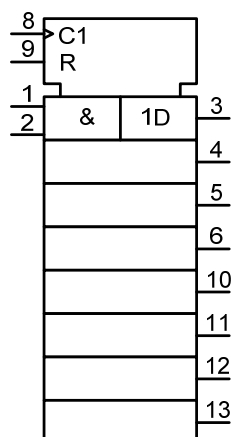

■ ABSOLUTE MAXIMUM RATING (Unless otherwise specified)

PARAMETER	SYMBOL	RATINGS	UNIT
Supply Voltage	V_{CC}	-0.5 ~ 7.0	V
V_{CC} or GND Current	I_{CC}	±50	mA
Output Current	I_{OUT}	±25	mA
Input Diode Current	I_{IK}	±20	mA
Switch Diode Current	I_{OK}	±20	mA
Storage Temperature	T_{STG}	-65 ~ +150	°C

Note: Absolute maximum ratings are those values beyond which the device could be permanently damaged. Absolute maximum ratings are stress ratings only and functional device operation is not implied.

■ RECOMMENDED OPERATING COMDITIONS

PARAMETER	SYMBOL	CONDITIONS	MIN	TYP	MAX	UNIT
Supply Voltage	V_{CC}		2.0	5.0	6.0	V
Input Voltage	V_{IN}		0		V_{CC}	V
Output Voltage	V_{OUT}		0		V_{CC}	V
Input Transition Rise or Fall Rate	$\Delta t/\Delta v$	$V_{CC}=2V$			1000	ns
		$V_{CC}=4.5V$		6.0	500	ns
		$V_{CC}=6V$			400	ns
Operating Temperature	T_A		-40		+125	°C

■ THERMAL DATA

PARAMETER	SYMBOL	RATINGS	UNIT
Ambient to Junction	DIP-14	100	°C/W
	SOP-14U	125	°C/W
	TSSOP-14U	150	°C/W

■ ELECTRICAL CHARACTERISTICS (Unless otherwise specified)

PARAMETER	SYMBOL	TEST CONDITIONS	MIN	TYP	MAX	UNIT
Input Voltage High-Level	V_{IH}	$V_{CC}=2.0V$	1.5	1.2		V
		$V_{CC}=4.5V$	3.15	2.4		V
		$V_{CC}=6.0V$	4.2	3.2		V
Input Voltage Low-Level	V_{IL}	$V_{CC}=2.0V$		0.8	0.5	V
		$V_{CC}=4.5V$		2.1	1.35	V
		$V_{CC}=6.0V$		2.8	1.8	V
Output Voltage High-Level	V_{OH}	$V_{CC}=2.0V, I_{OH}=20\mu A$	1.9	2.0		V
		$V_{CC}=4.5V, I_{OH}=20\mu A$	4.4	4.5		V
		$V_{CC}=6.0V, I_{OH}=20\mu A$	5.9	6.0		V
		$V_{CC}=4.5V, I_{OH}=4mA$	3.98	4.32		V
		$V_{CC}=6.0V, I_{OH}=5.2mA$	5.48	5.81		V
Output Voltage Low-Level	V_{OL}	$V_{CC}=2.0V, I_{OL}=20\mu A$		0	0.1	V
		$V_{CC}=4.5V, I_{OL}=20\mu A$		0	0.1	V
		$V_{CC}=6.0V, I_{OL}=20\mu A$		0	0.1	V
		$V_{CC}=4.5V, I_{OL}=4mA$		0.15	0.26	V
		$V_{CC}=6.0V, I_{OL}=5.2mA$		0.16	0.26	V
Input Leakage Current	$I_{I(LEAK)}$	$V_{IN}=V_{CC}$ or GND, $V_{CC}=6.0V$			±0.1	μA
Quiescent Supply Current	I_Q	$V_{IN}=V_{CC}$ or GND, $V_{CC}=6.0V, I_{OUT}=0$			8	μA
Input Capacitance	C_{IN}			3.5		pF

■ DYNAMIC CHARACTERISTICS (GND=0V; $t_R=t_F=6\text{ns}$; $C_L=50\text{pF}$, unless otherwise specified)

PARAMETER	SYMBOL	TEST CONDITIONS	MIN	TYP	MAX	UNIT
Propagation Delay From CP to Qn	t_{PHL}, t_{PLH}	$V_{CC}=2.0\text{V}$		41	170	ns
		$V_{CC}=4.5\text{V}$		15	34	ns
		$V_{CC}=6.0\text{V}$		12	29	ns
Propagation Delay From $\overline{\text{MR}}$ to Qn	t_{PHL}	$V_{CC}=2.0\text{V}$		39	140	ns
		$V_{CC}=4.5\text{V}$		14	28	ns
		$V_{CC}=6.0\text{V}$		11	24	ns
Output Transition Time	t_{THL}, t_{TLH}	$V_{CC}=2.0\text{V}$		19	75	ns
		$V_{CC}=4.5\text{V}$		7	15	ns
		$V_{CC}=6.0\text{V}$		6	13	ns
Clock Pulse Width High or Low	t_w	$V_{CC}=2.0\text{V}$	80	14		ns
		$V_{CC}=4.5\text{V}$	16	5		ns
		$V_{CC}=6.0\text{V}$	14	4		ns
Master Reset Pulse Width Low	t_w	$V_{CC}=2.0\text{V}$	60	17		ns
		$V_{CC}=4.5\text{V}$	12	6		ns
		$V_{CC}=6.0\text{V}$	10	5		ns
Removal Time $\overline{\text{MR}}$ to CP	t_{rem}	$V_{CC}=2.0\text{V}$	60	17		ns
		$V_{CC}=4.5\text{V}$	12	6		ns
		$V_{CC}=6.0\text{V}$	10	5		ns
Setup Time DSA and DSB to CP	t_{SU}	$V_{CC}=2.0\text{V}$	60	8		ns
		$V_{CC}=4.5\text{V}$	12	3		ns
		$V_{CC}=6.0\text{V}$	10	2		ns
Hold Time DSA and DSB to CP	t_h	$V_{CC}=2.0\text{V}$	+4	-6		ns
		$V_{CC}=4.5\text{V}$	+4	-2		ns
		$V_{CC}=6.0\text{V}$	+4	-2		ns
Maximum Clock Pulse Frequency	f_{MAX}	$V_{CC}=2.0\text{V}$	6	23		MHz
		$V_{CC}=4.5\text{V}$	30	71		MHz
		$V_{CC}=6.0\text{V}$	35	85		MHz
Clock Frequency	f_{CLOCK}	$V_{CC}=2.0\text{V}$			6	MHz
		$V_{CC}=4.5\text{V}$			31	MHz
		$V_{CC}=6.0\text{V}$			36	MHz

■ OPERATING CHARACTERISTICS (Unless otherwise specified)

PARAMETER	SYMBOL	TEST CONDITIONS	MIN	TYP	MAX	UNIT
Power Dissipation Capacitance	C_{PD}	No load		40		pF

■ TEST CIRCUIT AND WAVEFORMS

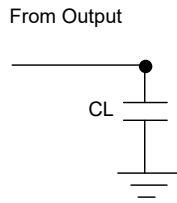

TEST CIRCUIT

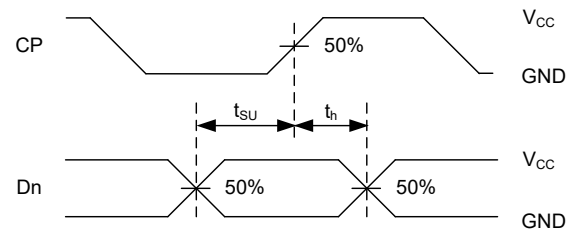

SETUP TIME AND HOLD TIME

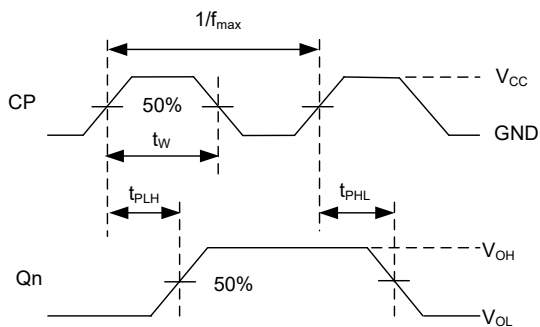

PROPAGATION DELAY TIMES FROM CP TO Qn

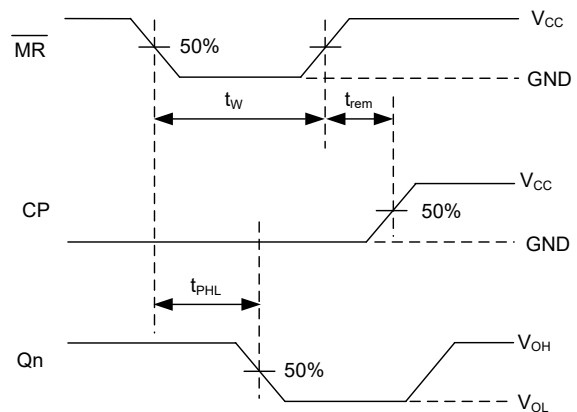

PROPAGATION DELAY TIMES FROM \overline{MR} TO Qn

UTC assumes no responsibility for equipment failures that result from using products at values that exceed, even momentarily, rated values (such as maximum ratings, operating condition ranges, or other parameters) listed in products specifications of any and all UTC products described or contained herein. UTC products are not designed for use in life support appliances, devices or systems where malfunction of these products can be reasonably expected to result in personal injury. Reproduction in whole or in part is prohibited without the prior written consent of the copyright owner. UTC reserves the right to make changes to information published in this document, including without limitation specifications and product descriptions, at any time and without notice. This document supersedes and replaces all information supplied prior to the publication hereof.