



2SC2625

NPN EPITAXIAL SILICON TRANSISTOR

HIGH VOLTAGE HIGH SPEED SWITCHING

■ **FEATURES**

- * High voltage, high speed switching
- * High reliability

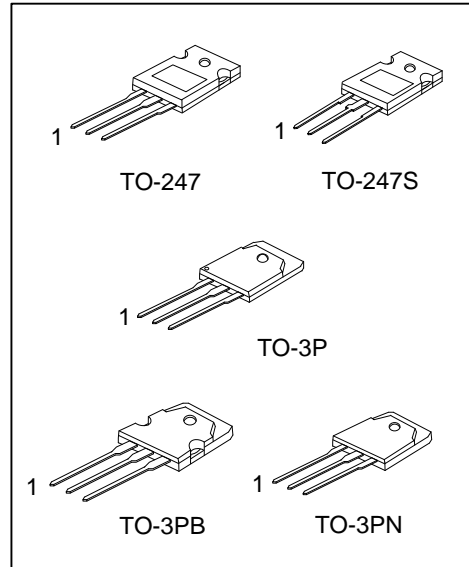

■ **ORDERING INFORMATION**

Ordering Number		Package	Pin Assignment			Packing
Lead Free	Halogen Free		1	2	3	
2SC2625L-T3P-T	2SC2625G-T3P-T	TO-3P	B	C	E	Tube
2SC2625L-T3B-T	2SC2625G-T3B-T	TO-3PB	B	C	E	Tube
2SC2625L-T3N-T	2SC2625G-T3N-T	TO-3PN	B	C	E	Tube
2SC2625L-T47-T	2SC2625G-T47-T	TO-247	B	C	E	Tube
2SC2625L-T47S-T	2SC2625G-T47S-T	TO-247S	B	C	E	Tube

Note: Pin Assignment: B: Base C: Collector E: Emitter

<p>2SC2625G-T3P-T</p>	<p>(1) T: Tube</p> <p>(2) T3P: TO-3P, T3B: TO-3PB, T3N: TO-3PN, T47: TO-247, T47S: TO-247S</p> <p>(3) G: Halogen Free and Lead Free, L: Lead Free</p>
-----------------------	-------------------------------------------------------------------------------------------------------------------------------------------------------

■ **MARKING**

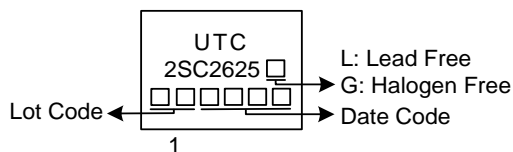

■ **ABSOLUTE MAXIMUM RATINGS** ($T_C=25^\circ\text{C}$, unless otherwise specified)

PARAMETER		SYMBOL	RATINGS	UNIT
Collector Base Voltage		V_{CBO}	450	V
Collector Emitter Voltage		V_{CEO}	400	V
		$V_{CEO(SUS)}$	400	V
Emitter Base Voltage		V_{EBO}	7	V
Collector Current		I_C	10	A
Base Current		I_B	3	A
Power Dissipation	TO-247/TO-247S	P_D	78	W
	TO-3P/TO-3PB		80	W
	TO-3PN			
Junction Temperature		T_J	+150	$^\circ\text{C}$
Storage Temperature		T_{STG}	-40 ~ +150	$^\circ\text{C}$

■ **THERMAL DATA**

PARAMETER		SYMBOL	RATINGS	UNIT
Junction to Case	TO-247/TO-247S	θ_{jC}	1.6	$^\circ\text{C/W}$
	TO-3P/TO-3PB		1.55	$^\circ\text{C/W}$
	TO-3PN			

■ **ELECTRICAL SPECIFICATIONS** ($T_C=25^\circ\text{C}$, unless otherwise specified)

PARAMETER	SYMBOL	TEST CONDITIONS	MIN	TYP	MAX	UNIT
Collector Base Voltage	V_{CBO}	$I_{CBO}=1\text{mA}$	450			V
Collector Emitter Voltage	V_{CEO}	$I_{CEO}=10\text{mA}$	400			V
	$V_{CEO(SUS)}$	$I_C=1\text{A}$	400			V
Emitter Base Voltage	V_{EBO}	$I_{EBO}=0.1\text{mA}$	7			V
Collector-Emitter Saturation Voltage	$V_{CE(Sat)}$	$I_C=4\text{A}, I_B=0.8\text{A}$			1.2	V
Base Emitter Saturation Voltage	$V_{BE(Sat)}$				1.5	V
Collector Cut-off Current	I_{CBO}	$V_{CBO}=450\text{V}$			1.0	mA
Emitter Cut-off Current	I_{EBO}	$V_{EBO}=7\text{V}$			0.1	mA
DC Current Gain	h_{FE}	$I_C=4\text{A}, V_{CE}=5\text{V}$	10			
Switching Time	t_{ON}	$I_C=7.5\text{A}, I_{B1}=-I_{B2}=1.5\text{A}$ $R_L=20\Omega, P_w=20\mu\text{s}, \text{Duty} \leq 2\%$			1.0	μs
	t_{STG}				2.0	μs
	t_F				1.0	μs

■ SWITCHING TIME TEST CIRCUIT

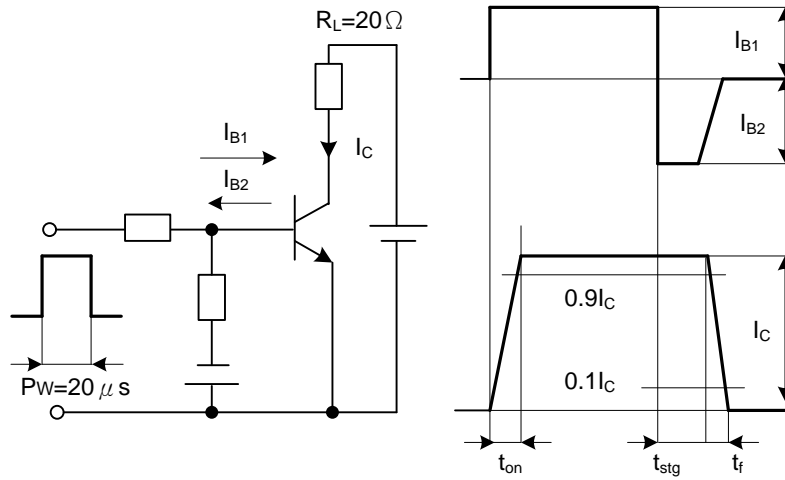

TYPICAL CHARACTERISTICS

Collector Output Characteristics

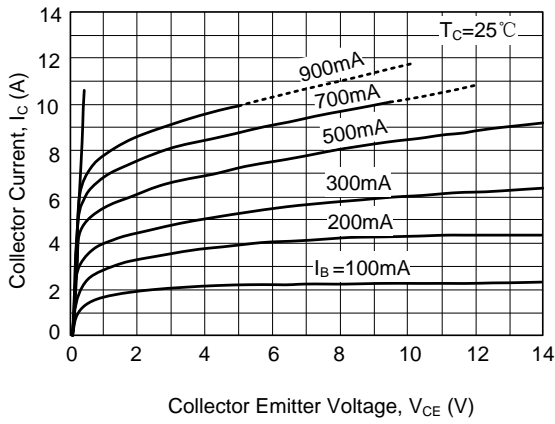

DC Current Gain

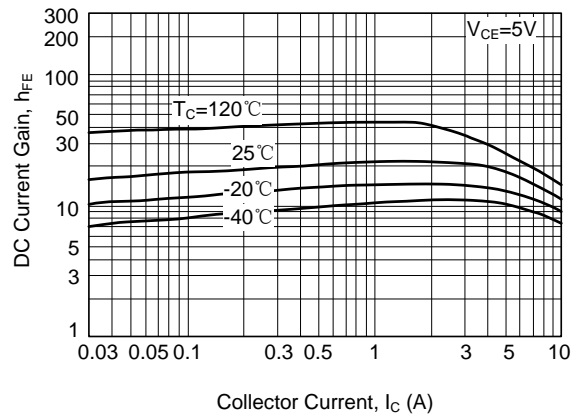

Base and Collector Saturation Voltage

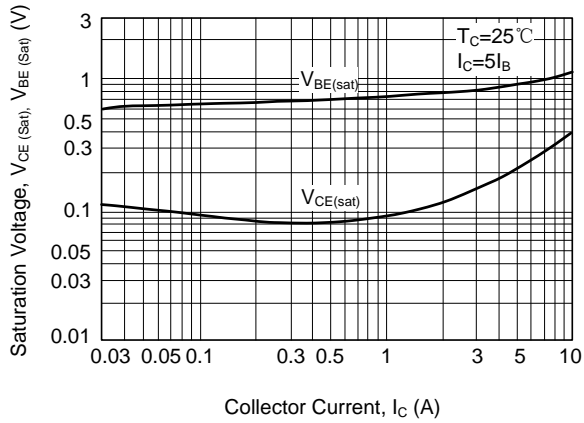

Safe Operating Area

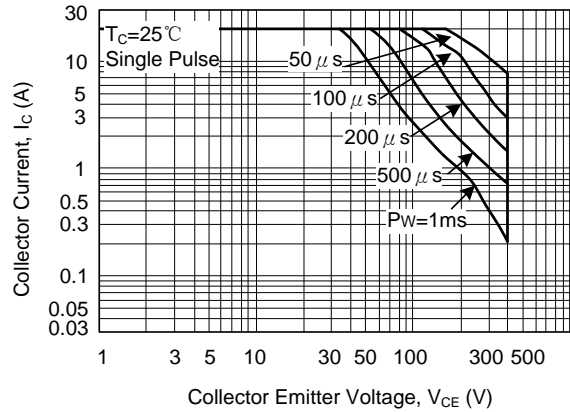

Switching Time

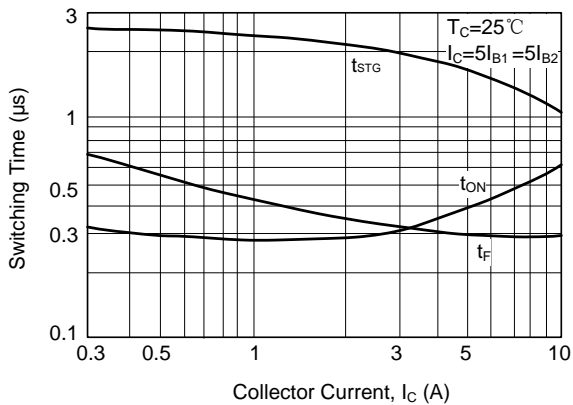

UTC assumes no responsibility for equipment failures that result from using products at values that exceed, even momentarily, rated values (such as maximum ratings, operating condition ranges, or other parameters) listed in products specifications of any and all UTC products described or contained herein. UTC products are not designed for use in life support appliances, devices or systems where malfunction of these products can be reasonably expected to result in personal injury. Reproduction in whole or in part is prohibited without the prior written consent of the copyright owner. UTC reserves the right to make changes to information published in this document, including without limitation specifications and product descriptions, at any time and without notice. This document supersedes and replaces all information supplied prior to the publication hereof.