



UNISONIC TECHNOLOGIES CO., LTD

MMBT9013

NPN SILICON TRANSISTOR

1W OUTPUT AMPLIFIER OF
POTABLE RADIOS IN CLASS
B PUSH-PULL OPERATION

FEATURES

- *High total Power Dissipation. (625mW)
- *High Collector Current. (500mA)
- *Excellent h_{FE} linearity.
- *Complementary to UTC MMBT9012

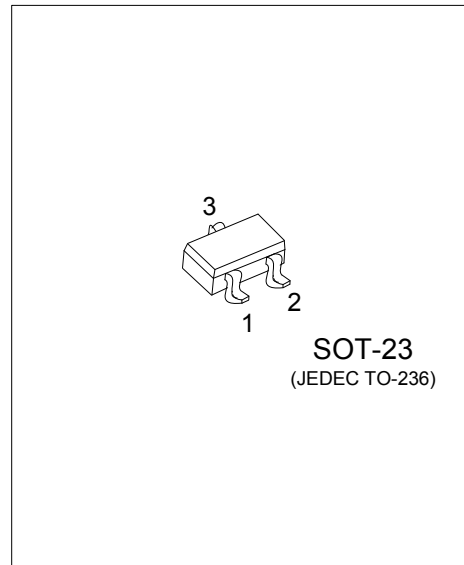

ORDERING INFORMATION

Ordering Number		Package	Pin Assignment			Packing
Lead Free	Halogen Free		1	2	3	
MMBT9013L-x-AE3-R	MMBT9013G-x-AE3-R	SOT-23	B	E	C	Tape Reel

Note: Pin Assignment: B: Base E: Emitter C: Collector

<p>MMBT9013G-x-AE3-R</p>	<p>(1) R: Tape Reel</p> <p>(2) AE3: SOT-23</p> <p>(3) x: refer to Classification of h_{FE1}</p> <p>(4) G: Halogen Free and Lead Free, L: Lead Free</p>
--------------------------	---

MARKING

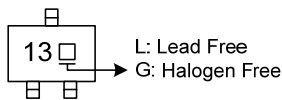

MMBT9013

NPN SILICON TRANSISTOR

■ ABSOLUTE MAXIMUM RATINGS ($T_A=25^{\circ}\text{C}$, unless otherwise specified)

PARAMETER	SYMBOL	RATING	UNIT
Collector-Base Voltage	V_{CBO}	40	V
Collector-Emitter Voltage	V_{CEO}	20	V
Emitter-Base Voltage	V_{EBO}	5	V
Collector Current	I_C	500	mA
Collector Dissipation	P_C	225	mW
Operating Junction Temperature	T_J	-40 ~ +150	$^{\circ}\text{C}$
Storage Temperature	T_{STG}	-55 ~ +150	$^{\circ}\text{C}$

■ ELECTRICAL CHARACTERISTICS ($T_A=25^{\circ}\text{C}$, unless otherwise specified)

PARAMETER	SYMBOL	TEST CONDITIONS	MIN	TYP	MAX	UNIT
Collector-Base Breakdown Voltage	BV_{CBO}	$I_C=100\mu\text{A}, I_E=0$	40			V
Collector-Emitter Breakdown Voltage	BV_{CEO}	$I_C=1\text{mA}, I_B=0$	20			V
Emitter-Base Breakdown Voltage	BV_{EBO}	$I_E=100\mu\text{A}, I_C=0$	5			V
Collector-Emitter Saturation Voltage	$V_{CE(SAT)}$	$I_C=500\text{mA}, I_B=50\text{mA}$		0.16	0.6	V
Base-Emitter Saturation Voltage	$V_{BE(SAT)}$	$I_C=500\text{mA}, I_B=50\text{mA}$		0.91	1.2	V
Base-Emitter On Voltage	$V_{BE(ON)}$	$V_{CE}=1\text{V}, I_C=10\text{mA}$	0.6	0.67	0.7	V
Collector Cutoff Current	I_{CBO}	$V_{CB}=25\text{V}, I_E=0$			100	nA
Emitter Cutoff Current	I_{EBO}	$V_{EB}=3\text{V}, I_C=0$			100	nA
DC Current Gain	h_{FE1}	$V_{CE}=1\text{V}, I_C=50\text{mA}$	64	120	300	
	h_{FE2}	$V_{CE}=1\text{V}, I_C=500\text{mA}$	40	120		

■ CLASSIFICATION OF h_{FE1}

RANK	D	E	F	G	H	I
RANGE	64-91	78-112	96-135	112-166	144-202	190-300

TYPICAL CHARACTERISTICS

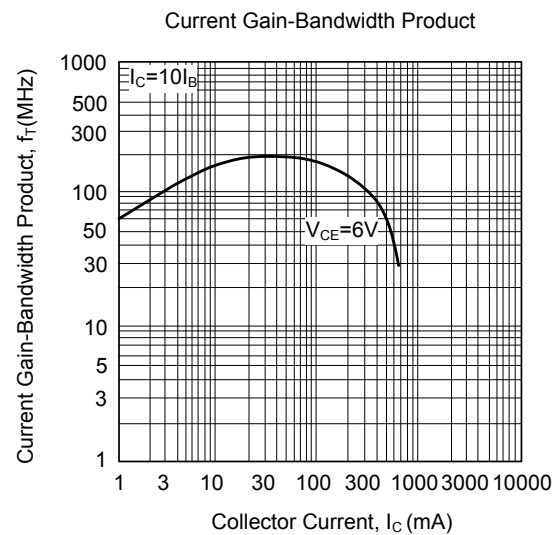
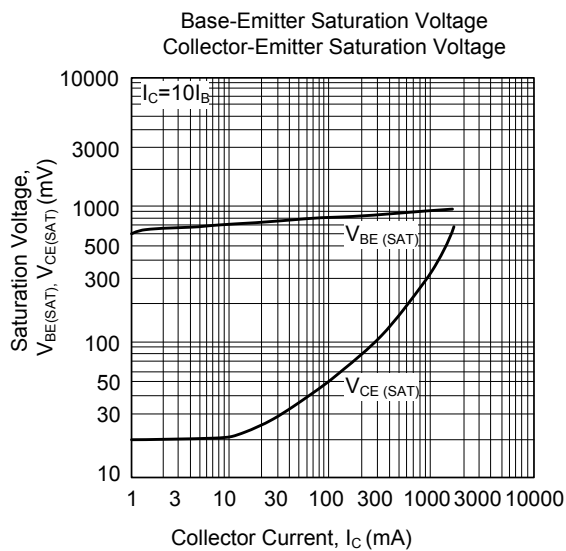
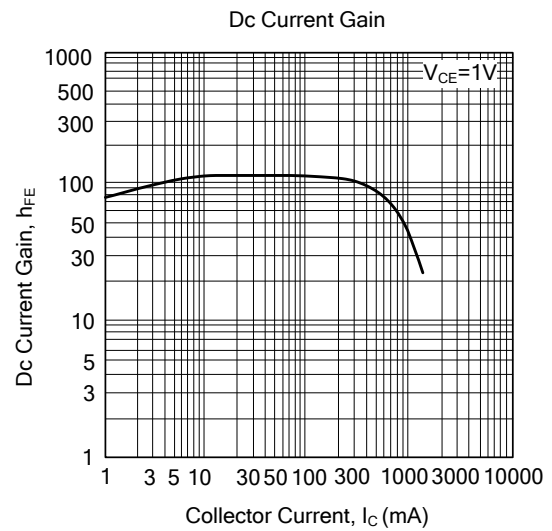
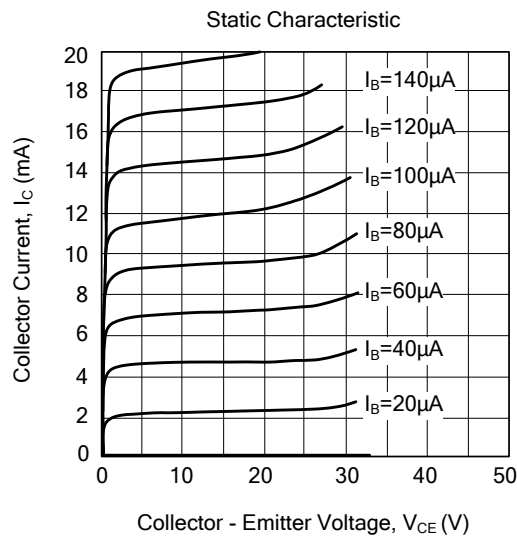

UTC assumes no responsibility for equipment failures that result from using products at values that exceed, even momentarily, rated values (such as maximum ratings, operating condition ranges, or other parameters) listed in products specifications of any and all UTC products described or contained herein. UTC products are not designed for use in life support appliances, devices or systems where malfunction of these products can be reasonably expected to result in personal injury. Reproduction in whole or in part is prohibited without the prior written consent of the copyright owner. UTC reserves the right to make changes to information published in this document, including without limitation specifications and product descriptions, at any time and without notice. This document supersedes and replaces all information supplied prior to the publication hereof.