



TIP31C

NPN EXPITAXIAL TRANSISTOR

NPN EXPITAXIAL PLANAR TRANSISTOR

■ DESCRIPTION

The UTC **TIP31C** is a NPN epitaxial planar transistor, designed for using in general purpose amplifier and switching applications.

■ FEATURES

* Complement to TIP32C.

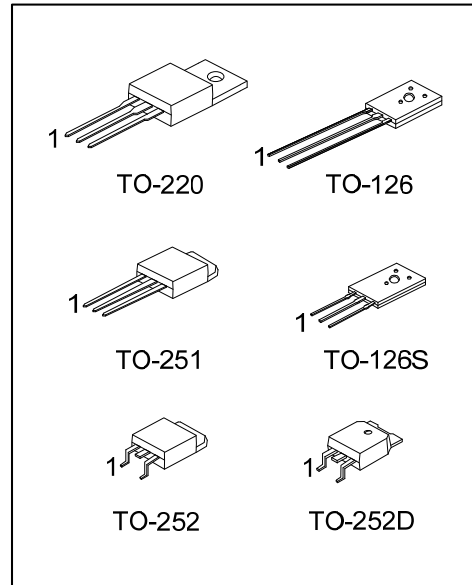

■ ORDERING INFORMATION

Ordering Number		Package	Pin Assignment			Packing
Lead Free	Halogen Free		1	2	3	
TIP31CL-TA3-T	TIP31CG-TA3-T	TO-220	B	C	E	Tube
TIP31CL-TM3-T	TIP31CG-TM3-T	TO-251	B	C	E	Tube
TIP31CL-TN3-R	TIP31CG-TN3-R	TO-252	B	C	E	Tape Reel
TIP31CL-TND-R	TIP31CG-TND-R	TO-252D	B	C	E	Tape Reel
TIP31CL-T60-K	TIP31CG-T60-K	TO-126	B	C	E	Bulk
TIP31CL-T6S-K	TIP31CG-T6S-K	TO-126S	B	C	E	Bulk

Note: Pin Assignment: B: Base C: Collector E: Emitter

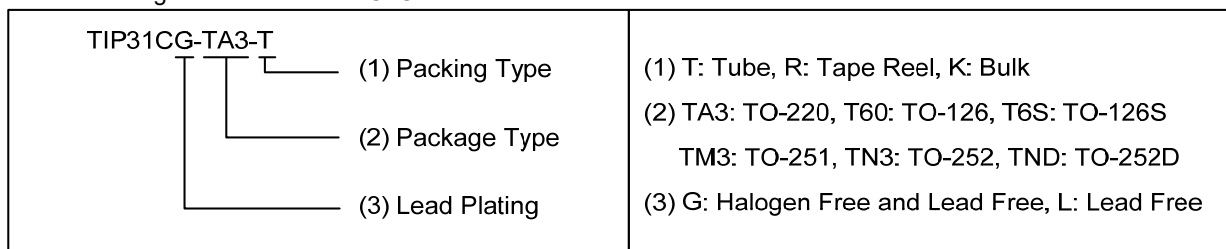

■ MARKING

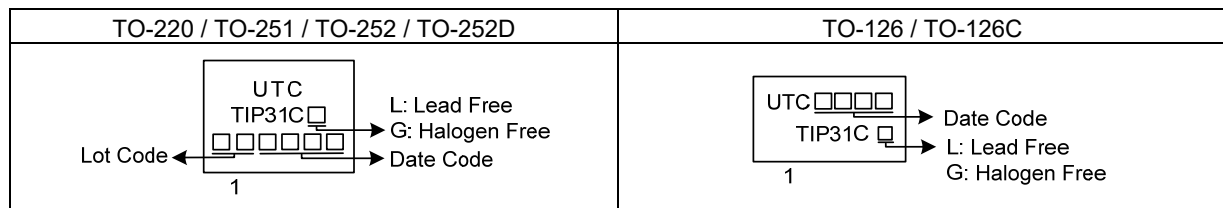

■ ABSOLUTE MAXIMUM RATINGS

PARAMETER		SYMBOL	RATINGS	UNIT
Collector-Base Voltage		V_{CBO}	100	V
Collector-Emitter Voltage		V_{CEO}	100	V
Emitter-Base Voltage		V_{EBO}	5	V
Collector Current	DC	I_C	3	A
	Pulse		5	A
Base Current		I_B	1	A
Collector Dissipation ($T_A=25^\circ\text{C}$)	TO-126/TO-126S	P_C	1.4	W
	TO-220		2	W
	TO-251/TO-252		1.56	W
	TO-252D			
Collector Dissipation ($T_C=25^\circ\text{C}$)	TO-126/TO-126S		10	W
	TO-220		40	W
	TO-251/TO-252	15	W	
	TO-252D			
Junction Temperature		T_J	+150	$^\circ\text{C}$
Storage Temperature		T_{STG}	-65 ~ +150	$^\circ\text{C}$

Note: Absolute maximum ratings are those values beyond which the device could be permanently damaged. Absolute maximum ratings are stress ratings only and functional device operation is not implied.

■ THERMAL DATA (NOTE)

PARAMETER		SYMBOL	RATINGS	UNIT
Junction to Ambient	TO-126/TO-126S	θ_{JA}	89	$^\circ\text{C/W}$
	TO-220		62.5	$^\circ\text{C/W}$
	TO-251/TO-252		80	$^\circ\text{C/W}$
	TO-252D			
Junction to Case	TO-126/TO-126S	θ_{JC}	12.5	$^\circ\text{C/W}$
	TO-220		3.125	$^\circ\text{C/W}$
	TO-251/TO-252		8.33	$^\circ\text{C/W}$
	TO-252D			

Note: These ratings are applicable when surface mounted on the minimum pad sizes recommended.

■ ELECTRICAL CHARACTERISTICS ($T_C=25^\circ\text{C}$, unless otherwise specified)

PARAMETER	SYMBOL	TEST CONDITIONS	MIN	TYP	MAX	UNIT
Collector Emitter Sustaining Voltage (Note)	BV_{CEO}	$I_C=30\text{mA}, I_B=0$	100			V
Collector Cutoff Current	I_{CES}	$V_{CE}=100\text{V}, V_{EB}=0$			200	μA
Collector Cutoff Current	I_{CEO}	$V_{CE}=60\text{V}, I_B=0$			0.3	mA
Emitter Cutoff Current	I_{EBO}	$V_{EB}=5\text{V}, I_C=0$			1	mA
Collector-Emitter Saturation Voltage (Note)	$V_{CE(SAT)}$	$I_C=3\text{A}, I_B=375\text{mA}$			1.2	V
Base-Emitter On Voltage (Note)	$V_{BE(ON)}$	$I_C=3\text{A}, V_{CE}=4\text{V}$			1.8	V
DC Current Gain (Note)	h_{FE1}	$I_C=1\text{A}, V_{CE}=4\text{V}$	25			
	h_{FE2}	$I_C=3\text{A}, V_{CE}=4\text{V}$	10		50	
Current Gain Bandwidth Product	f_T	$I_C=0.5\text{A}, V_{CE}=10\text{V} f=1\text{MHz}$	3			MHz

Note: Pulse Test: $PW \leq 300\mu\text{s}$, Duty Cycle $\leq 2\%$.

TYPICAL CHARACTERISTICS

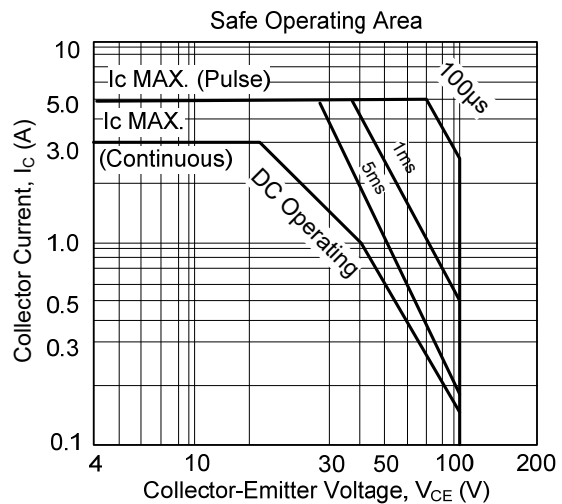
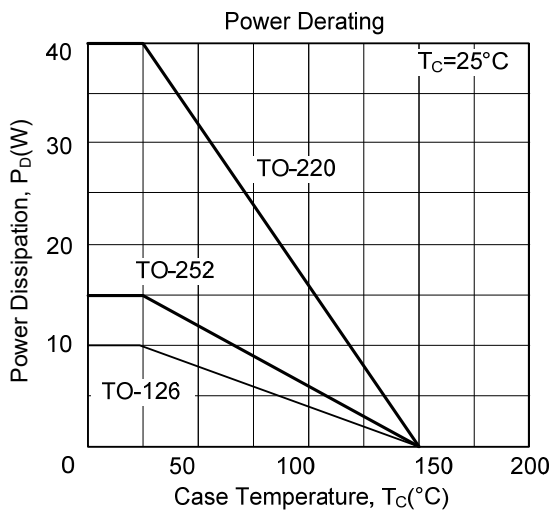
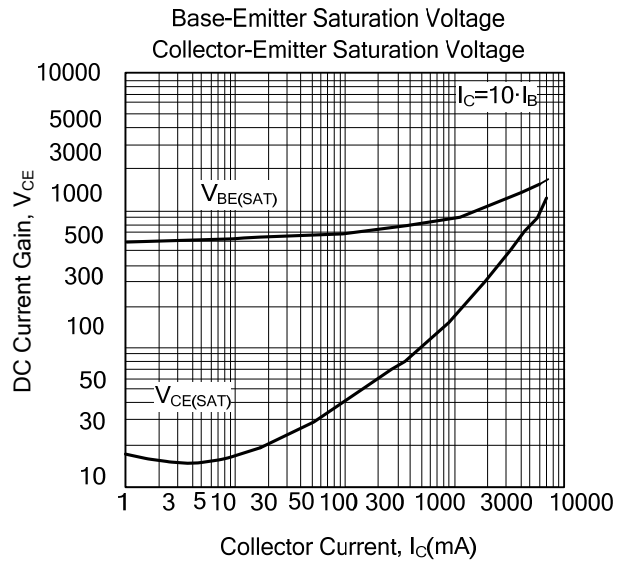
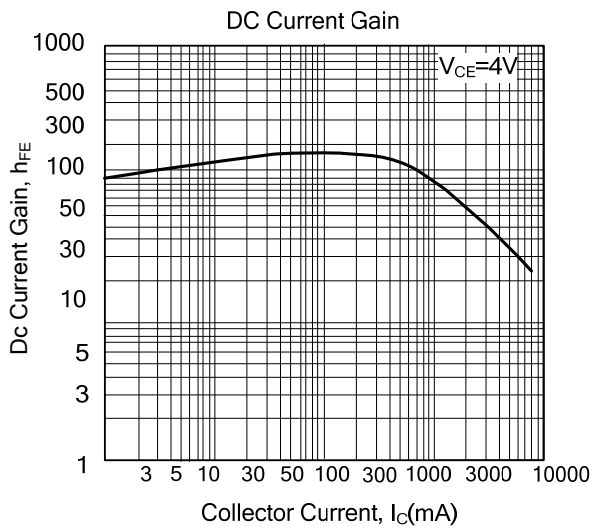

UTC assumes no responsibility for equipment failures that result from using products at values that exceed, even momentarily, rated values (such as maximum ratings, operating condition ranges, or other parameters) listed in products specifications of any and all UTC products described or contained herein. UTC products are not designed for use in life support appliances, devices or systems where malfunction of these products can be reasonably expected to result in personal injury. Reproduction in whole or in part is prohibited without the prior written consent of the copyright owner. UTC reserves the right to make changes to information published in this document, including without limitation specifications and product descriptions, at any time and without notice. This document supersedes and replaces all information supplied prior to the publication hereof.