



UT30P03

Power MOSFET

P-CHANNEL ENHANCEMENT MODE POWER MOSFET

FEATURES

- * $R_{DS(ON)} \leq 40m\Omega @ V_{GS}=-10V, I_D = -10A$
 $R_{DS(ON)} \leq 60m\Omega @ V_{GS}=-4.5V, I_D = -10A$
- * Low Capacitance
- * Optimized gate charge
- * Fast switching capability
- * Avalanche energy specified

SYMBOL

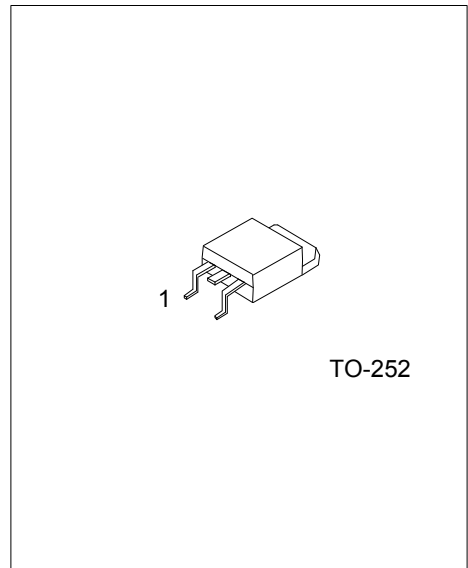
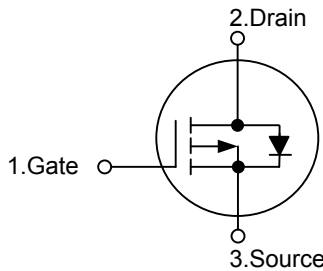

ORDERING INFORMATION

Ordering Number		Package	Pin Assignment			Packing
Lead Free	Halogen Free		1	2	3	
UT30P03L-TN3-R	UT30P03G-TN3-R	TO-252	G	D	S	Tape Reel

Note: Pin Assignment: G: Gate D: Drain S: Source

<p>UT30P03G-TN3-R</p> <p>(1) Packing Type (2) Package Type (3) Green Package</p>	<p>(1) R: Tape Reel (2) TN3: TO-252 (3) G: Halogen Free and Lead Free, L: Lead Free</p>
--	---

MARKING

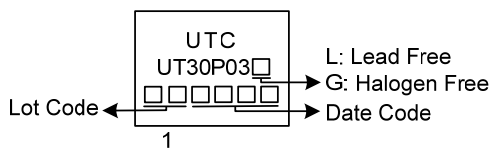

■ ABSOLUTE MAXIMUM RATINGS ($T_c = 25^\circ\text{C}$, unless otherwise specified)

PARAMETER	SYMBOL	RATINGS	UNIT
Drain-Source Voltage	V_{DSS}	-30	V
Gate-Source Voltage	V_{GSS}	± 20	V
Continuous Drain Current	I_D	-30	A
Pulsed Drain Current (Note 2)	I_{DM}	-60	A
Avalanche Energy	Single Pulsed (Note 3) E_{AS}	16	mJ
Peak Diode Recovery dv/dt (Note 4)	dv/dt	1.35	V/ns
Power Dissipation	P_D	50	W
Junction Temperature	T_J	+150	$^\circ\text{C}$
Storage Temperature	T_{STG}	-55 ~ +150	$^\circ\text{C}$

Notes: 1. Absolute maximum ratings are those values beyond which the device could be permanently damaged.

Absolute maximum ratings are stress ratings only and functional device operation is not implied.

2. Repetitive Rating: Pulse width limited by maximum junction temperature.

3. $L = 0.1\text{mH}$, $I_{AS} = 18\text{A}$, $V_{DD} = 50\text{V}$, $R_G = 25\ \Omega$, Starting $T_J = 25^\circ\text{C}$

4. $I_{SD} \leq 30\text{A}$, $di/dt \leq 200\text{A}/\mu\text{s}$, $V_{DD} \leq BV_{DSS}$, Starting $T_J = 25^\circ\text{C}$

■ THERMAL DATA

PARAMETER	SYMBOL	RATINGS	UNIT
Junction to Ambient	θ_{JA}	50	$^\circ\text{C}/\text{W}$
Junction to Case	θ_{JC}	3 (Note)	$^\circ\text{C}/\text{W}$

Note: Device mounted on FR-4 substrate P_c board, 2oz copper, with 1inch square copper plate.

■ ELECTRICAL CHARACTERISTICS (T_J=25°C, unless otherwise specified)

PARAMETER	SYMBOL	TEST CONDITIONS	MIN	TYP	MAX	UNIT
OFF CHARACTERISTICS						
Drain-Source Breakdown Voltage	BV _{DSS}	V _{GS} =0V, I _D =-250 μA	-30			V
Drain-Source Leakage Current	I _{DSS}	V _{DS} =-30V, V _{GS} =0V			-1	μA
Gate-Source Leakage Current	I _{GSS}	V _{GS} =±20V, V _{DS} =0V			±100	nA
ON CHARACTERISTICS						
Gate Threshold Voltage	V _{GS(TH)}	V _{DS} =V _{GS} , I _D =-250 μA	-1.0		-3.0	V
Static Drain-Source On-State Resistance (Note)	R _{DS(ON)}	V _{GS} =-10V, I _D =-10A			40	mΩ
		V _{GS} =-4.5V, I _D =-10A			60	mΩ
DYNAMIC CHARACTERISTICS						
Input Capacitance	C _{ISS}	V _{DS} =-25V, V _{GS} =0V, f=1.0MHz		756		pF
Output Capacitance	C _{OSS}			120		pF
Reverse Transfer Capacitance	C _{RSS}			80		pF
SWITCHING CHARACTERISTICS						
Total Gate Charge	Q _G	V _{DS} =-15V, V _{GS} =-10V, I _D =-1.0A I _G =1mA (Note 1, 2)		28		nC
Gate-Source Charge	Q _{GS}			3.5		nC
Gate-Drain Charge	Q _{GD}			3.2		nC
Turn-On Delay Time	t _{D(ON)}	V _{DS} =-15V, V _{GS} =-10V, I _D =-1.0A, R _G =25Ω (Note 1, 2)		30		ns
Turn-On Rise Time	t _R			36		ns
Turn-Off Delay Time	t _{D(OFF)}			302		ns
Turn-Off Fall Time	t _F			155		ns
SOURCE- DRAIN DIODE RATINGS AND CHARACTERISTICS						
Maximum Continuous Drain-Source Diode Forward Current	I _S				-30	A
Maximum Pulsed Drain-Source Diode Forward Current	I _{SM}				-60	A
Drain-Source Diode Forward Voltage	V _{SD}	V _{GS} =0V, I _S =-10A			-1.2	V
Reverse Recovery Time	t _{rr}	V _{GS} =0V, I _S =-10A, dI _F /dt=100A/μs (Note1)		88		ns
Reverse Recovery Charge	Q _{rr}			105		nC

Notes: 1. Pulse Test: Pulse width ≤ 300μs, Duty cycle ≤ 2%.

2. Essentially independent of operating temperature.

■ TEST CIRCUITS AND WAVEFORMS

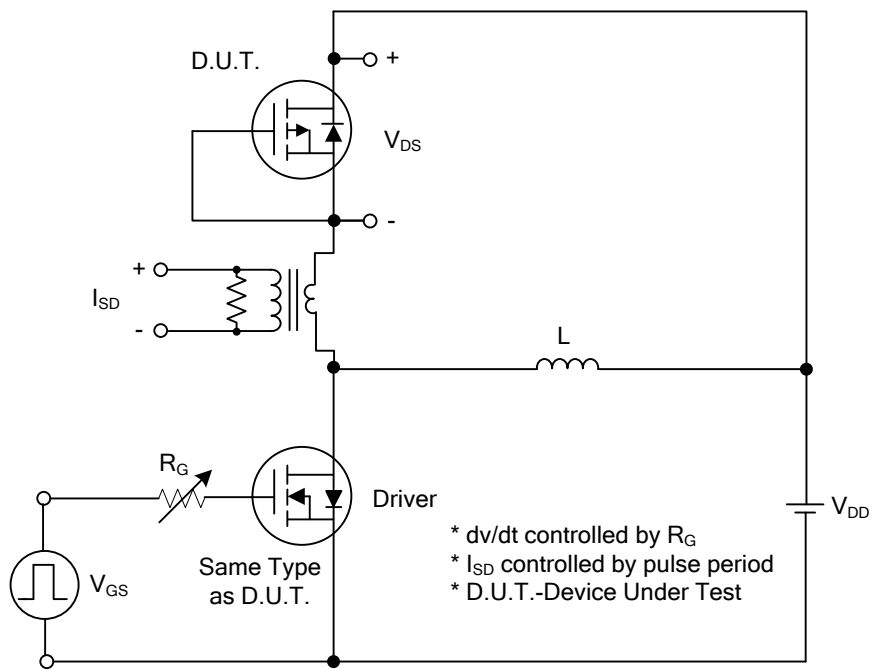

Peak Diode Recovery dv/dt Test Circuit

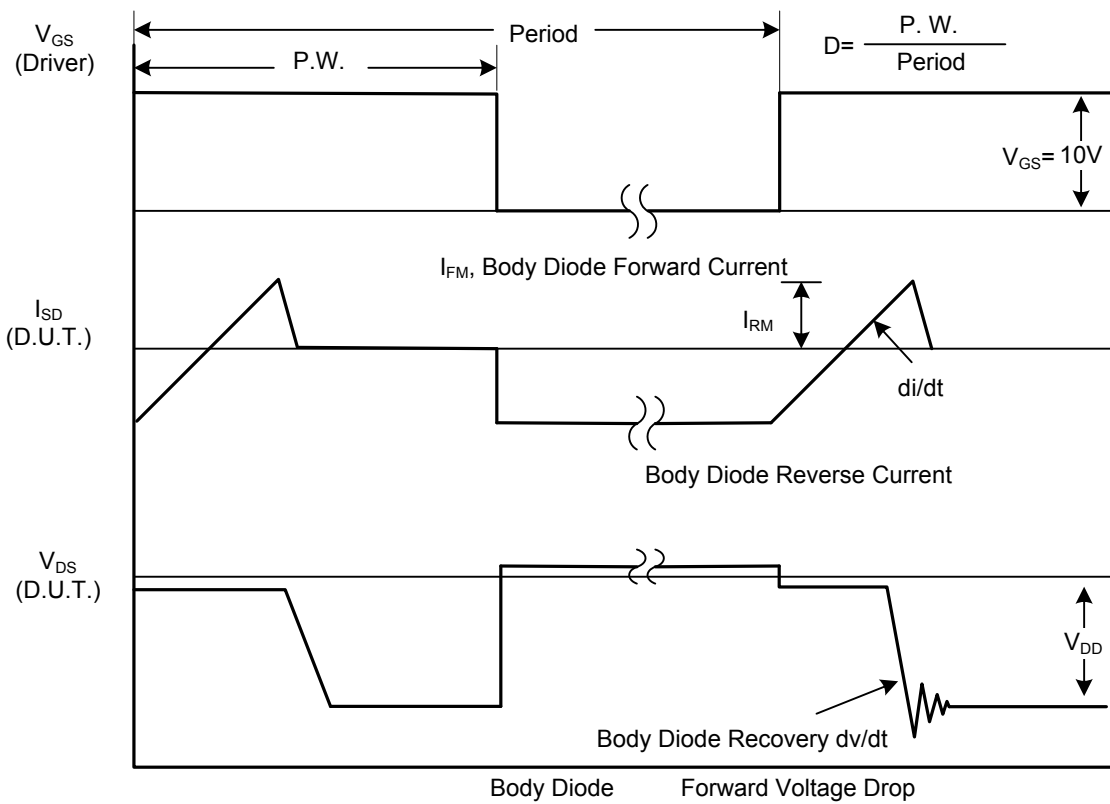

Peak Diode Recovery dv/dt Waveforms

TEST CIRCUITS AND WAVEFORMS

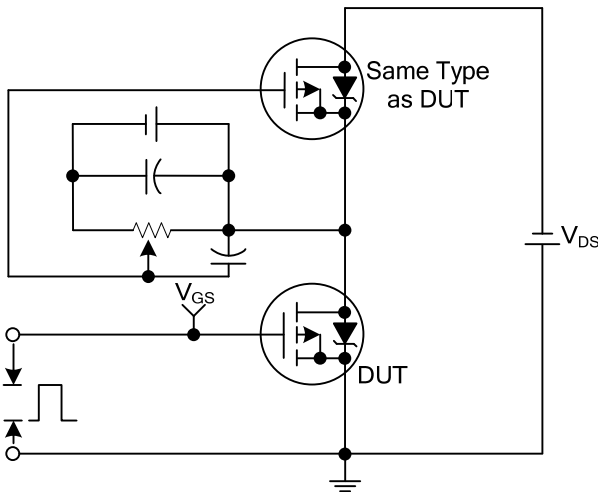

Gate Charge Test Circuit

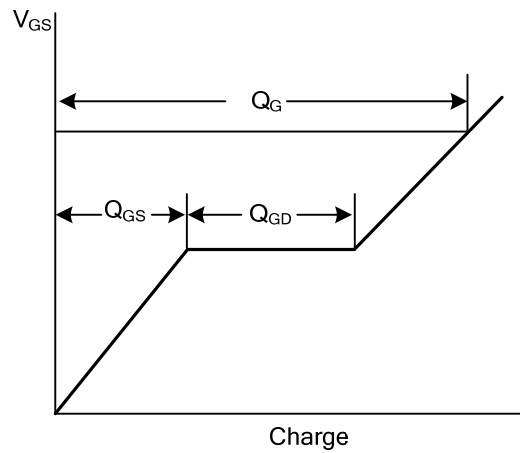

Gate Charge Waveforms

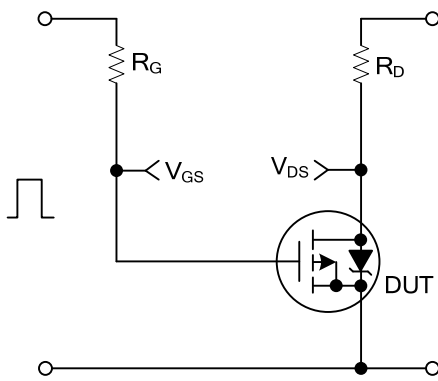

Resistive Switching Test Circuit

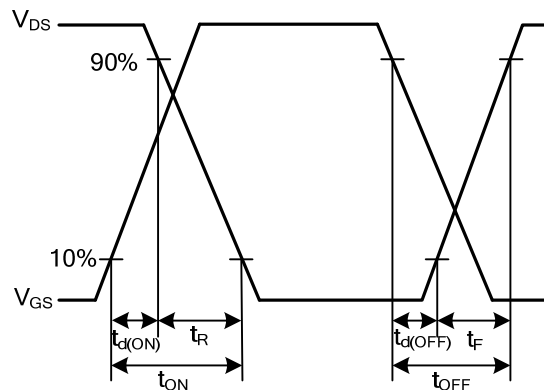

Resistive Switching Waveforms

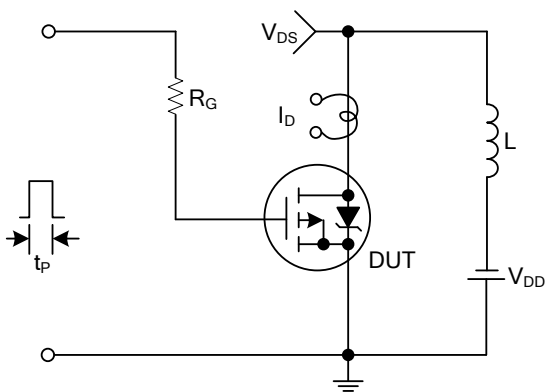

Unclamped Inductive Switching Test Circuit

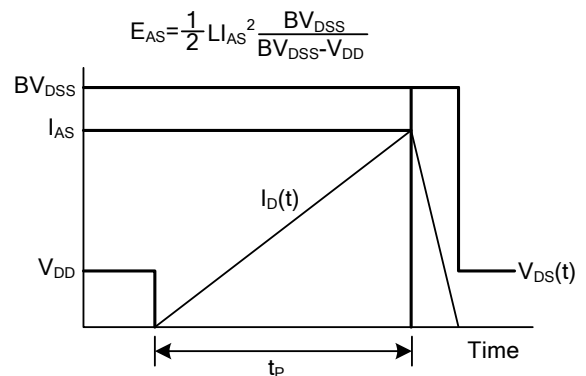

Unclamped Inductive Switching Waveforms

TYPICAL CHARACTERISTICS

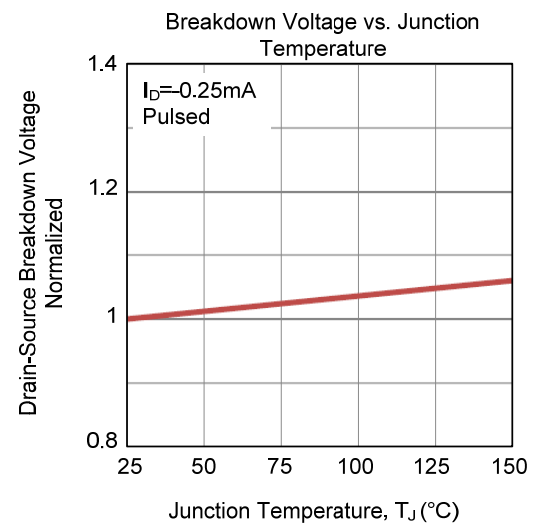
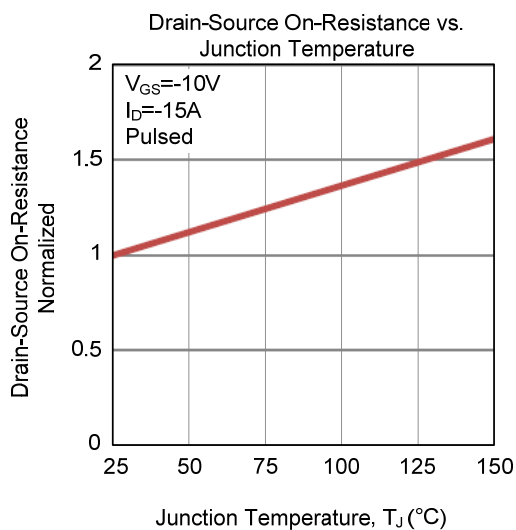
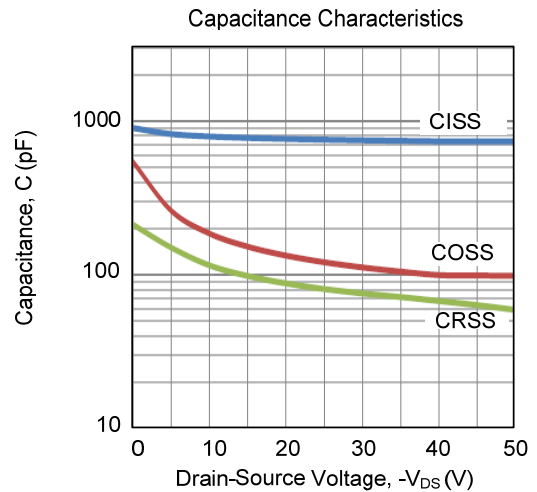
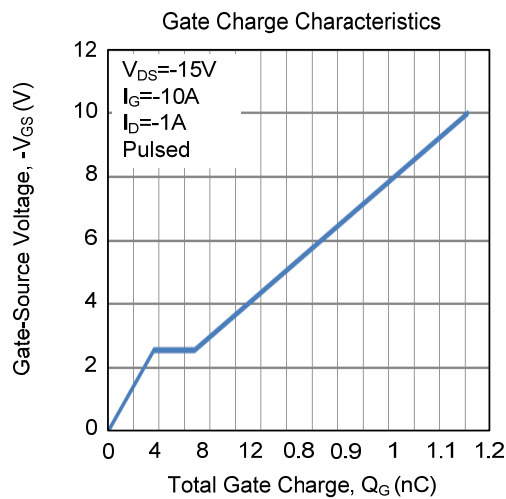
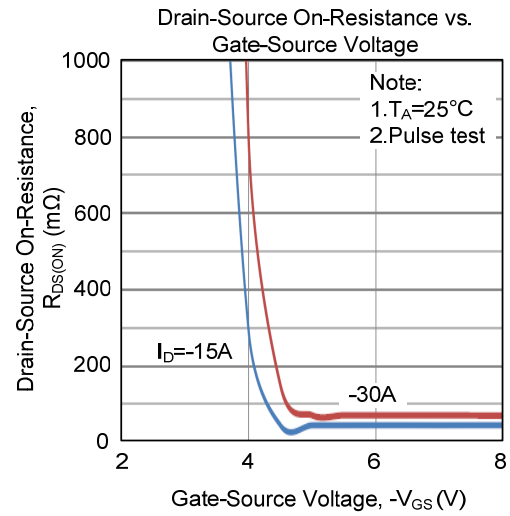
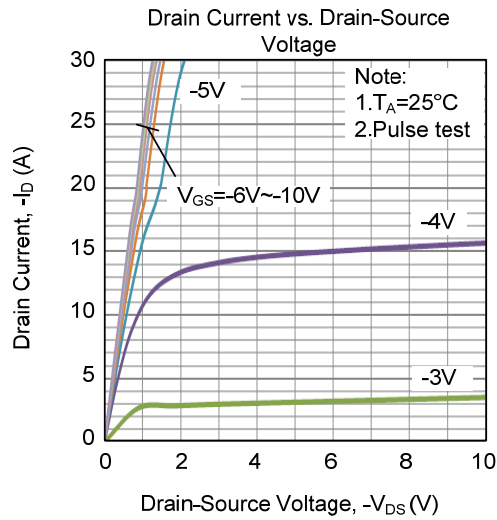

■ TYPICAL CHARACTERISTICS (Cont.)

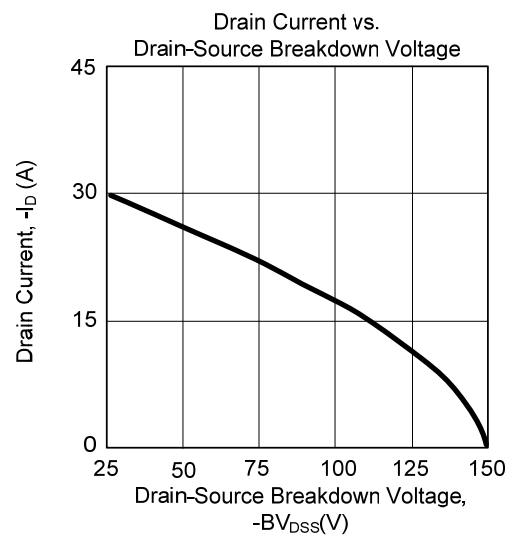
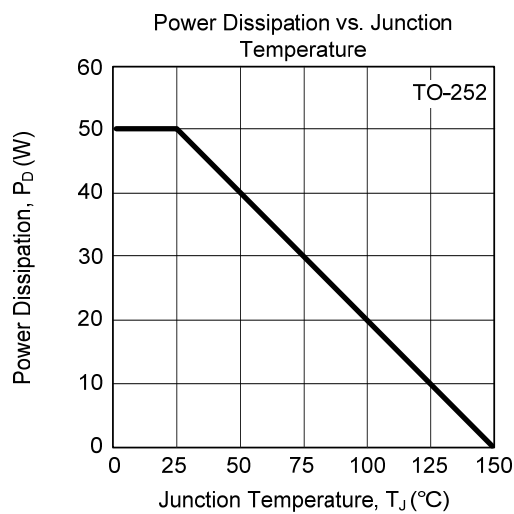
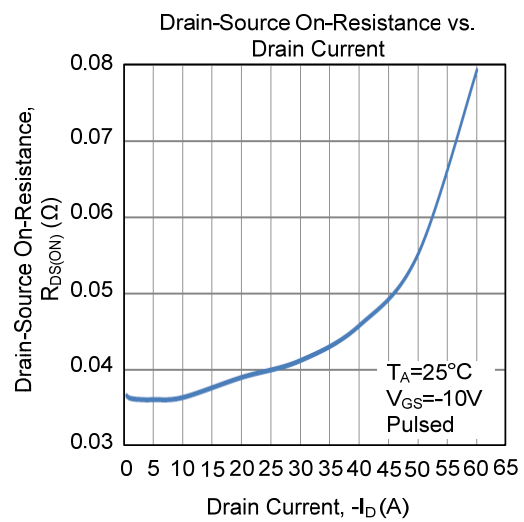
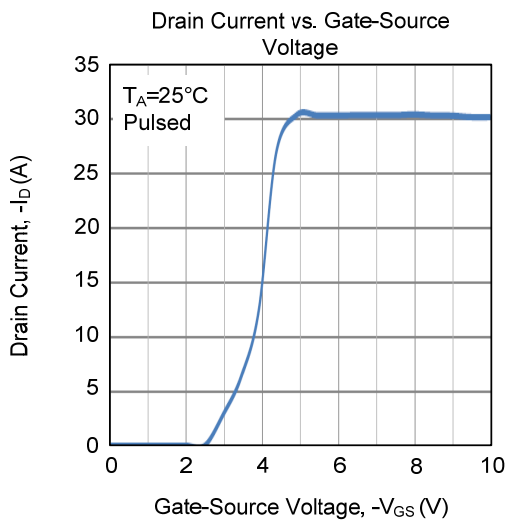
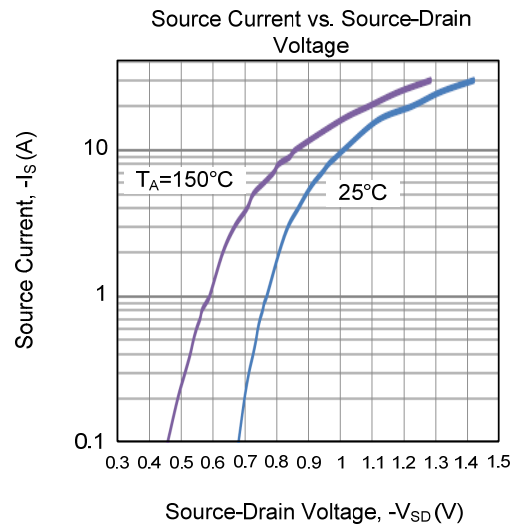
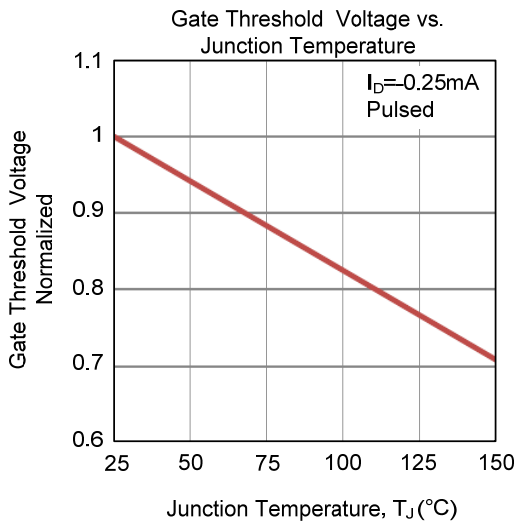

■ TYPICAL CHARACTERISTICS (Cont.)

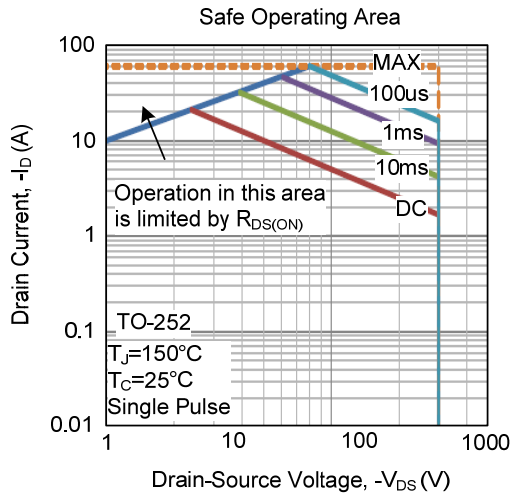

UTC assumes no responsibility for equipment failures that result from using products at values that exceed, even momentarily, rated values (such as maximum ratings, operating condition ranges, or other parameters) listed in products specifications of any and all UTC products described or contained herein. UTC products are not designed for use in life support appliances, devices or systems where malfunction of these products can be reasonably expected to result in personal injury. Reproduction in whole or in part is prohibited without the prior written consent of the copyright owner. UTC reserves the right to make changes to information published in this document, including without limitation specifications and product descriptions, at any time and without notice. This document supersedes and replaces all information supplied prior to the publication hereof.