



L8565

Preliminary

LINEAR INTEGRATED CIRCUIT

HIGH PERFORMANCE POWER FACTOR CORRECTION CONTROLLER IN CONTINUOUS CONDUCTION MODE

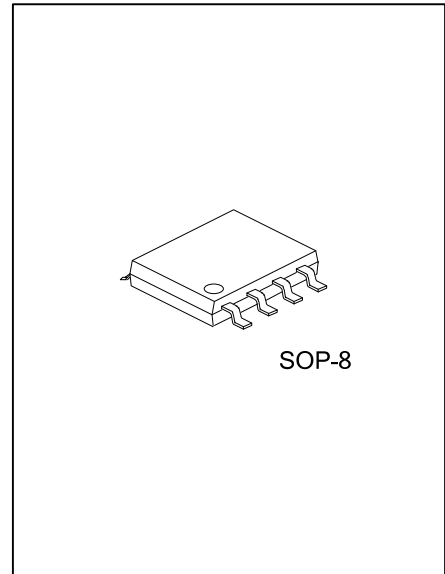

DESCRIPTION

The UTC **L8565** is a wide input range controller integrated circuit for active power factor correction. The circuit is designed for boost PFC application, and requires reduced external component count. Its power supply is recommended to be provided by an external auxiliary supply which will switch on and off the IC.

The circuit operates in the continuous conduction mode under average current, and in discontinuous conduction mode only in light load condition. The switching frequency can be set with the external resistor at pin 4. Both current and voltage loop compensations are done externally to allow full user control.

There are many kinds of protection features incorporated to make sure of safe system operation conditions, such as brown-out protection, output under voltage detection and peak current limitation. The inside reference is adjusted (5V±2%) to make sure control level and precise protection. There is a particular soft-start function to limit the start up current and thus reduces the stress on the boost diode.

FEATURES

- * Supports wide input range
- * Average current control
- * Ease of use with few external components
- * External current and voltage loop compensation
- * Trimmed internal reference voltage (5V±2%)
- * Programmable operating/switching frequency (50kHz ~ 250kHz)
- * Max duty cycle of 95% (typ) at 125kHz
- * Under voltage lockout
- * Cycle by cycle peak current limiting
- * Over-voltage protection
- * Open loop detection
- * Output under-voltage detection
- * Brown-out protection
- * Soft Over current Protection
- * Enhanced dynamic response

ORDERING INFORMATION

Ordering Number		Package	Packing
Lead Free	Halogen Free		
L8565L-S08-R	L8565G-S08-R	SOP-8	Tape Reel

<p>L8565G-S08-R</p> <ul style="list-style-type: none"> (1)Packing Type (2)Package Type (3)Green Package 	<ul style="list-style-type: none"> (1) R: Tape Reel (2) S08: SOP-8 (3) G: Halogen Free and Lead Free, L: Lead Free
--	---

■ PIN CONFIGURATION

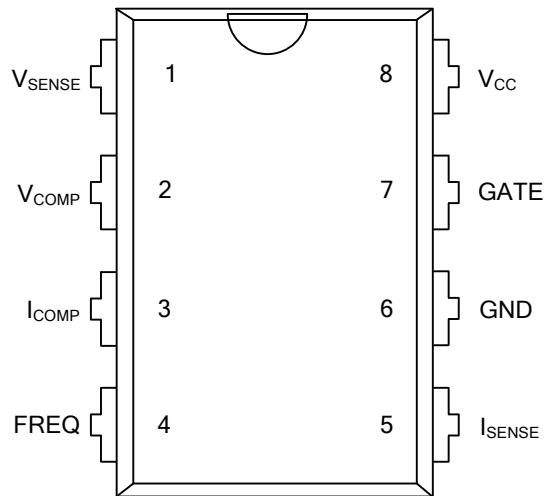
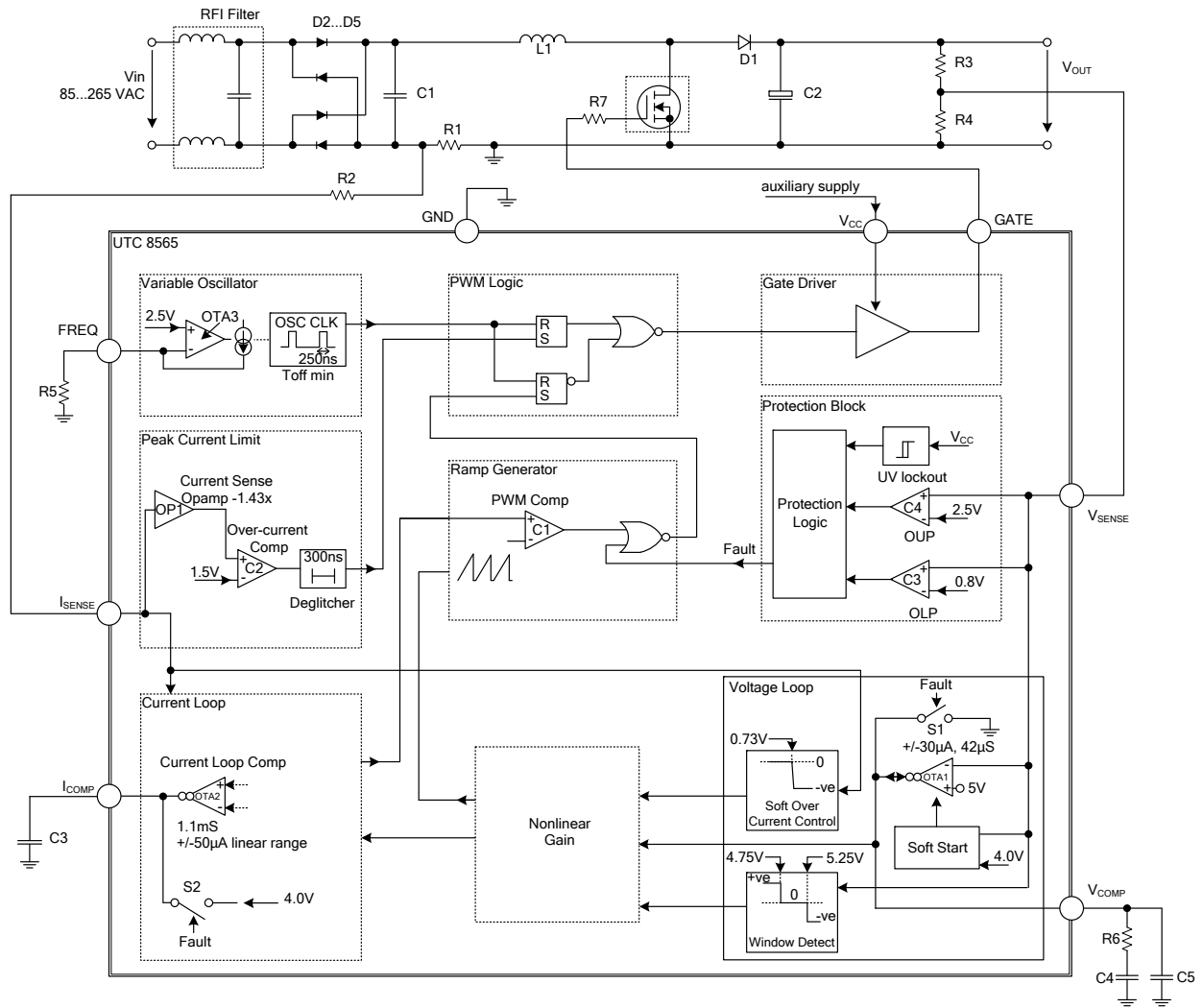

Figure 1. Pin Configuration (top view)

■ PIN DESCRIPTION

PIN NO.	PIN NAME	DESCRIPTION
1	V_{SENSE}	The output bus voltage of the boost converter is sensed at this pin via a resistive divider. The reference voltage for this pin is 5V.
2	V_{COMP}	This V_{COMP} Pin provides the compensation of the output voltage loop with a compensation network to ground (see Figure 2). This also gives the soft start function which controls an increasing AC input current during start-up.
3	I_{COMP}	At this pin the compensation components of the current loop are connected. The capacitor which is connected at this pin integrates the output current of OTA2 and averages the current sense signal.
4	FREQ	A resistor connected to this pin sets the fixed switching frequency. The frequency range is from 50kHz to 250kHz.
5	I_{SENSE}	The pin senses the negative voltage drop at the external sense resistor (R_1). This is the input signal for the average current regulation in the current loop. It is also fed to the peak current limitation block. During power up time, high inrush currents cause high voltage drop at R_1 , driving currents into pin 5 which could be beyond the absolute maximum ratings. Therefore a series resistor (R_2) of around 220 Ω is recommended in order to limit this current into the IC.
6	GND	This is the Ground pin.
7	GATE	The GATE pin is the output of the internal driver stage, which has a capability of 1.5A source and sink current. Its gate drive voltage is clamped at 11.5V (typically).
8	V_{CC}	The V_{CC} pin is the positive supply of the IC and should be connected to an external auxiliary supply. The operating range is between 10V and 21V. The turn-on threshold is at 11.2V and under voltage occurs at 10.2V.

■ BLOCK DIAGRAM



Representative Block diagram

■ ABSOLUTE MAXIMUM RATINGS

PARAMETER	SYMBOL	RATINGS	UNIT
V _{CC} Supply Voltage	V _{CC}	-0.3 ~ 22	V
FREQ Voltage	V _{FREQ}	-0.3 ~ 7	V
I _{COMP} Voltage	V _{ICOMP}	-0.3 ~ 7	V
I _{SENSE} Voltage	V _{ISENSE}	-24 ~ 7	V
I _{SENSE} Current	I _{ISENSE}	±1	mA
V _{SENSE} Voltage	V _{VSENSE}	-0.3 ~ 7	V
V _{SENSE} Current	I _{VSENSE}	±1	mA
V _{COMP} Voltage	V _{VCOMP}	-0.3 ~ 7	V
GATE Voltage	V _{GATE}	-0.3 ~ 22	V
Junction Temperature	T _J	-40 ~ 150	°C
Storage Temperature	T _{STG}	-55 ~ 150	°C

Note: Absolute maximum ratings are those values beyond which the device could be permanently damaged. Absolute maximum ratings are stress ratings only and functional device operation is not implied.

■ THERMAL DATA

PARAMETER	SYMBOL	RATINGS	UNIT
Junction to Ambient	θ _{JA}	90	K/W

■ ELECTRICAL CHARACTERISTICS

PARAMETER	SYMBOL	TEST CONDITIONS	MIN	TYP	MAX	UNIT
OPERATING RANGE (Note 1)						
V _{CC} Supply Voltage	V _{CC}		V _{CCUVLO}		21	V
Junction Temperature	T _{J(CON)}		-40		125	°C
SUPPLY SECTION (Note 2)						
V _{CC} Turn-On Threshold	V _{CCON}		10.5	11.2	11.9	V
V _{CC} Turn-Off Threshold/ Under Voltage Lock Out	V _{CCUVLO}		9.4	10.2	10.8	V
V _{CC} Turn-On/Off Hysteresis	V _{CCHY}		0.8	1	1.3	V
Start Up Current Before V _{CCON}	I _{CCSTART}	V _{VCC} =V _{VCC(ON)} -0.1V	50	100	200	μA
Operating Current With Active GATE	I _{CCHG}	R5=33kΩ, C _L =4.7nF	19	23	27	mA
Operating Current During Standby	I _{CCSTDBY}	R5 = 33kΩ, V _{VSENSE} =0.5V	1.6	2.3	3	mA
VARIABLE FREQUENCY SECTION						
Switching Frequency (Typical)	F _{SWNOM}	R5=33kΩ	110	125	150	kHz
Switching Frequency (Min.)	F _{SW(MIN)}	R5=82kΩ	40	56	70	kHz
Switching Frequency (Max.)	F _{SW(MAX)}	R5=15kΩ	200	250	320	kHz
Voltage At FREQ Pin	V _{FREQ}		2.40	2.50	2.60	V
PWM SECTION						
Max. Duty Cycle	D _{MAX}	F _{SW} =F _{SWNOM} (R5=33kΩ)	92	95	98	%
Min. Duty Cycle	D _{MIN}	V _{VCOMP} =0V, V _{VSENSE} =5V, V _{ICOMP} =6.4V			0	%
Min. Off Time	T _{OFF(MIN)}	V _{VCOMP} =5V, V _{VSENSE} =5V, V _{ISENSE} =0.1V	250	350	450	ns

■ ELECTRICAL CHARACTERISTICS(Cont.)

PARAMETER	SYMBOL	TEST CONDITIONS	MIN	TYP	MAX	UNIT
SYSTEM PROTECTION SECTION						
Open Loop Protection (OLP) V _{SENSE} Threshold	V _{OLP}		0.75	0.79	0.84	V
Peak Current Limitation (PCL) I _{SENSE} Threshold	V _{PCL}		-1.15	-1.08	-1.00	V
Soft Over Current Control (SOC) I _{SENSE} Threshold	V _{SOC}		-0.82	-0.76	-0.69	V
Output Under Voltage Detection (OUV) V _{SENSE} Threshold	V _{OUV}		2.5	2.6	2.7	V
Output Over-Voltage Protection (OVP)	V _{OVP}		5	5.1	5.2	V
CURRENT LOOP SECTION						
OTA2 Transconductance Gain	G _{MOTA2}	At Temp=25°C	0.9	1.1	1.3	mS
OTA2 Output Linear Range	I _{OTA2}	Guaranteed by design		±50		μA
I _{COMP} Voltage during OLP	V _{ICOMP}	V _{SENSE} =0.5V	3.6	4.0		V
VOLTAGE LOOP SECTION						
OTA1 Reference Voltage	V _{OTA1}		4.90	5.00	5.10	V
OTA1 Transconductance Gain	G _{MOTA1}		31.5	42	52.5	μS
OTA1 Max. Source Current Under Normal Operation	I _{OTA1SO}	V _{SENSE} =4.25V, V _{COMP} =4V	21	30	38	μA
OTA1 Max. Sink Current Under Normal Operation	I _{OTA1SK}	V _{SENSE} =6V, V _{COMP} =4V	21	30	38	μA
Soft Start End	V _{SOFT}		3.80	4.00	4.20	V
OTA1 Source Current Under Soft Start	I _{OTA1SS}	V _{SENSE} =2V, V _{COMP} =0V	8.5	10.5	12.5	μA
Enhanced Dynamic Response	V _{SENSE} High	V _{Hi}	4.92	5.05	5.18	V
	V _{SENSE} LOW	V _{Lo}	4.83	4.95	5.07	V
V _{SENSE} Input Bias Current At 5V	I _{SEN5V}	V _{SENSE} =5V	0		1.5	μA
V _{SENSE} Input Bias Current at 1V	I _{SEN1V}	V _{SENSE} =1V	0		1	μA
V _{COMP} Voltage during OLP	V _{VCOMP}	V _{SENSE} = 0.5V, I _{VCOMP} =0.5mA	0	0.2	0.4	V
DRIVER SECTION						
GATE Low Voltage	V _{GATEL}	V _{CC} =5V, I _{GATE} =5mA			1.2	V
		V _{CC} =5V, I _{GATE} =20mA			1.5	V
		I _{GATE} =0A		0.8		V
		I _{GATE} =20mA		1.6	2.0	V
		I _{GATE} =-20mA	-0.2	0.2		V
GATE High Voltage	V _{GATEH}	V _{CC} =20V, C _L =4.7nF		11.5		V
		V _{CC} =11V, C _L =4.7nF		10.5		V
		V _{CC} =V _{VCC(OFF)} +0.2V, C _L =4.7nF		7.5		V
GATE Rise Time	t _R	V _{GATE} =2V...9V, C _L =4.7nF		120		ns
GATE Fall Time	t _F	V _{GATE} =9V...2V, C _L =4.7nF		60		ns
GATE Current, Peak, Rising Edge	I _{GATE}	C _L =4.7nF (Note 3)	-1.5			A
GATE Current, Peak, Falling Edge	I _{GATE}	C _L =4.7nF (Note 3)			1.5	A

Notes: 1. Within the operating range the IC operates as described in the functional description.

2. The electrical characteristics involve the spread of values within the specified supply voltage and junction temperature range T_J from -40°C to 125°C. Typical values represent the median values, which are related to 25°C. If not otherwise stated, a supply voltage of V_{CC}=15V is assumed for test condition.

3. Design characteristics (not meant for production testing)

■ FUNCTIONAL DESCRIPTION

1. General

The UTC **L8565** is an active power factor correction controller for boost PFC application. The IC comes in DIP package and is suitable for wide input range applications from 85 to 265 V_{AC}. The IC is usually realized with boost converters and it operates in continuous conduction mode with average current control.

The UTC **L8565** operates with a cascaded control; the inner current loop and the outer voltage loop. The inner current loop of the IC controls the sinusoidal profile for the average input current. It uses the dependency of the PWM duty cycle on the line input voltage to determine the corresponding input current. This means the average input current follows the input voltage as long as the device operates in CCM. Under light load condition, depending on the choke inductance, the system may enter into discontinuous conduction mode (DCM). In DCM, the average current waveform will be distorted but the resultant harmonics are still low enough to meet the Class D requirement of IEC 1000-3-2. The outer loop controls the output voltage. Depending on the load condition, OTA1 establishes an appropriate voltage at V_{COMP} pin which controls the amplitude of the average input current.

The UTC **L8565** provides several protection features to ensure safe operating condition for both the system and device. Important protection features are namely Brown-out protection, Current Limitation and Output Under-voltage Protection.

2. Power Supply

The operating voltage range of the V_{CC} is from 10V to 21V. An internal under voltage lockout (UVLO) block monitors the V_{CC} power supply. As soon as it exceeds 11.2V and the voltage at pin 1 (V_{SENSE}) is >0.8V, the IC begins operating its gate drive and performs its Soft-Start as shown in Fig. 3.

If V_{CC} drops below 10.2V, the IC is off. The IC will then be consuming typically 200µA, whereas consuming 23mA during normal operation.

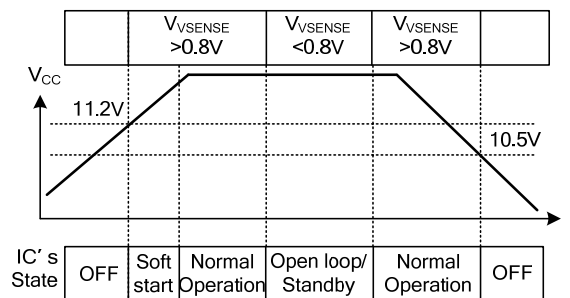

Fig. 3. State of Operation Respect to V_{CC}

The IC can be turned off and forced into standby mode by pulling down the voltage at pin 1 (V_{SENSE}) to lower than 0.8V. The current consumption is reduced to 3mA in this mode.

FUNCTIONAL DESCRIPTION(Cont.)

3. Start-up (Soft-Start)

The operation of OTA1 during startup is shown in Fig. 4 and 5.

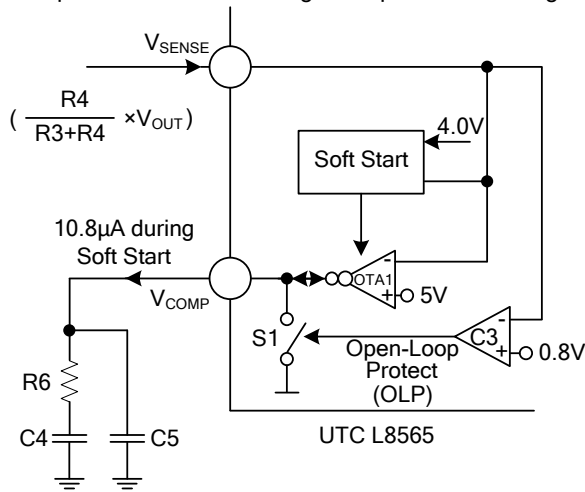

Fig. 4 Soft Start Circuit

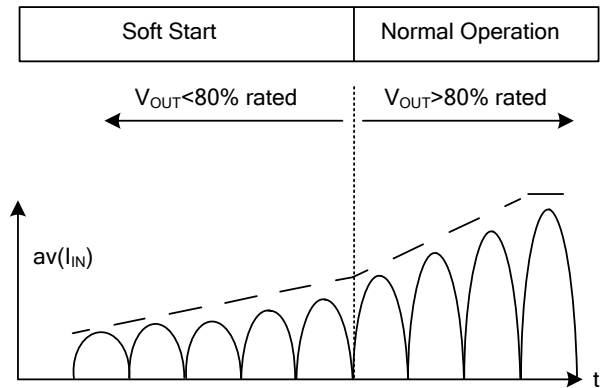

Fig. 5 Soft Start With Controlled Current

It sources a constant 10.8µA into the compensation network at pin 2 (V_{COMP}). The voltage at this pin rises linearly and so does the amplitude of the input current. As soon as the output voltage V_{OUT} reaches 80% of its rated level, the startup procedure is finished and the normal voltage control takes over. In normal operation, the IC operates with a higher maximum current at OTA1 and therefore with a higher voltage loop gain in order to improve the dynamic behavior of the device.

The advantage of this technique is a soft-start function with lower stress for the boost diode but without the risk of audible noise.

4. System Protection

The IC is equipped with various protection features to ensure the PFC system in safe operating range. Depending on the input line voltage (V_{IN}) and output bus voltage (V_{OUT}), When these protections are active the conditions are shown in Fig. 6 and 7.

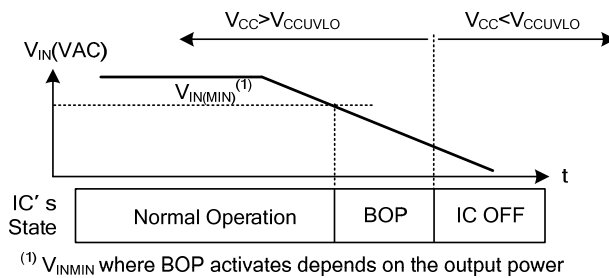

Fig. 6 V_{IN} Related Protection Features

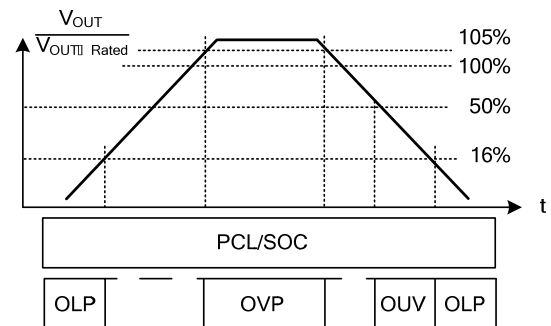

Fig. 7 V_{OUT} Related Protection Features

The following sections describe the functionality of these protection features.

FUNCTIONAL DESCRIPTION(Cont.)

4.1 Brown-Out Protection (BOP)

Input Brown-out occurs if the input voltage V_{IN} falls below the minimum input voltage of the design (i.e. 85V for universal input voltage range) and the V_{CC} has not entered into the V_{CC} under voltage lockout level yet. For a system without BOP, the boost converter will increasingly draw a higher current from the mains at a given output power which may exceed the maximum design values of the input current. The UTC **L8565** limits internally the current drawn from the mains and therefore also limits the input power. The difference of input and output power will result in decreasing output voltage. If the condition prolongs, the decreasing V_{OUT} will terminate in output under voltage condition (OUV, 50% of rated), and the IC will be shut down (See section 4.5).

Fig. 8 shows the occurrence of BOP in respect to the I_{SENSE} voltage.

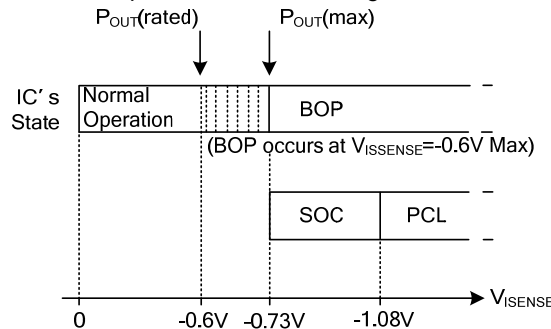

Fig. 8 BOP, SOC and PCL Protection as Function of V_{ISENSE}

The V_{IN} threshold for BOP to occur is dependent on the voltage at I_{SENSE} and thus the output power. The rated output power with a minimum V_{IN} ($V_{IN(MIN)}$) is

$$P_{OUT(rated)} = V_{IN(MIN)} \times \frac{0.6}{R1 \times \sqrt{2}}$$

Due to the internal parameter tolerance, the maximum power with $V_{IN(MIN)}$ before BOP occurs is

$$P_{OUT(max)} = V_{IN(MIN)} \times \frac{0.73}{R1 \times \sqrt{2}}$$

And the BOP takes over the normal operation under rated output power latest at an input voltage of

$$V_{BOPMAX} = P_{OUT(rated)} \times \frac{R1 \times \sqrt{2}}{0.73}$$

4.2 Soft Over Current Control (SOC)

The UTC **L8565** is designed not to support any output power that corresponds to a voltage lower than -0.76V at the I_{SENSE} pin. A further increase in the inductor current, which results in a lower I_{SENSE} voltage, will activate the Soft Over Current Control (SOC). This is a soft control as it does not directly switch off the gate drive like the PCL. It acts on the nonlinear gain block to result in a reduced PWM duty cycle.

4.3 Peak Current Limit (PCL)

The UTC **L8565** is equipped with a cycle by cycle peak current protection feature. It is active when the voltage at pin 5 (I_{SENSE}) reaches -1.08V. This voltage is amplified by OP1 with a factor of -1.43 and connected to comparator C2 with a reference voltage of 1.5V as shown in Fig. 9. A deglitcher with 300ns after the comparator improves noise immunity to the activation of this protection.

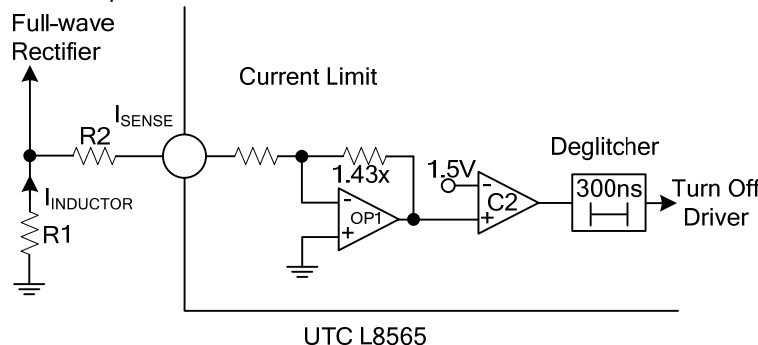

Fig. 9 Peak Current Limit (PCL)

■ FUNCTIONAL DESCRIPTION(Cont.)

4.4 Open Loop Protection / Input Under Voltage Protect (OLP)

Whenever V_{SENSE} voltage falls below 0.8V, or equivalently V_{OUT} falls below 16% of its rated value, it indicates an open loop condition (i.e. V_{SENSE} pin not connected) or an insufficient input voltage V_{IN} for normal operation. In this case, most of the blocks within the IC will be shutdown. The function is implemented using comparator C3 with a threshold of 0.8V as shown in the IC block diagram in Fig. 2.

4.5 Output Under Voltage Detection (OUV)

In the event of main interrupt or brown-out condition, the PFC system is not able to deliver the rated output power. This will cause the output voltage V_{OUT} to drop below its rated value. The IC provides an output under voltage detection that checks if V_{OUT} is falling below 50% of its rated value. Comparator C4 as shown in the device block diagram (Fig. 2) senses the voltage at pin 1 (V_{SENSE}) with a reference of 2.5V. If comparator C4 trips, the IC will be shut down as in OLP. The IC will be ready to restart if there is sufficient V_{IN} to pull V_{OUT} out of OLP.

4.6 Over-Voltage Protection (OVP)

Whenever V_{OUT} exceeds the rated value by 5%, the over-voltage protection OVP is active as shown in Fig. 7. This is implemented by sensing the voltage at pin V_{SENSE} with respect to a reference voltage of 5.05V. A V_{SENSE} voltage higher than 5.05V will immediately reduce the output duty cycle, bypassing the normal voltage loop control. This results in a lower input power to reduce the output voltage V_{OUT} .

5. Frequency Setting

The switching frequency of the PFC controller is fixed and can be set by an external resistor R5 at FREQ pin. The pin voltage V_{FREQ} is typically 2.5V. The corresponding capacitor for the oscillator is integrated in the device and the R5/frequency relationship is given at the "Electrical Characteristic" section. The recommended operating frequency range is from 50kHz to 250kHz. As an example, a R5 of 33k Ω at pin FREQ will set a switching frequency f_{SW} of 125kHz typically.

6. Average Current Control

6.1 Complete Current Loop

Fig. 10 show the complete system current loop. It consists of the current loop block which averages the voltage at pin I_{SENSE} , resulted from the inductor current flowing across R1. The averaged waveform is compared with an internal ramp in the ramp generator and PWM block. Once the ramp crosses the average waveform, the comparator C1 turns on the driver stage through the PWM logic block. The Nonlinear Gain block defines the amplitude of the inductor current. The following sections describe the functionality of each individual blocks.

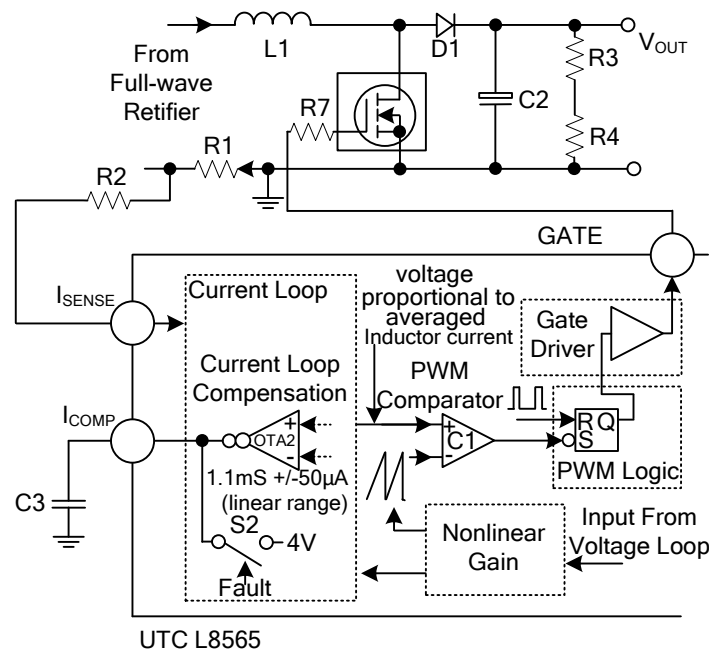

Fig. 10 Complete System Current Loop

■ FUNCTIONAL DESCRIPTION(Cont.)

6.2 Current Loop Compensation

The compensation of the current loop is done at the ICOMP pin. This is the OTA2 output and a capacitor C3 has to be installed at this node to ground (see Fig. 10). Under normal mode of operation, this pin gives a voltage which is proportional to the averaged inductor current. This pin is internally shorted to 5V in the event of IC shuts down when OLP and UVLO occur.

6.3 Pulse Width Modulation (PWM)

The IC employs an average current control scheme in continuous conduction mode (CCM) to achieve the power factor correction.

Assuming the voltage loop is working and output voltage is kept constant, the off duty cycle D_{OFF} for a CCM PFC system is given as

$$D_{OFF} = \frac{V_{IN}}{V_{OUT}}$$

From the above equation, D_{OFF} is proportional to V_{IN} . The objective of the current loop is to regulate the average inductor current such that it is proportional to the off duty cycle D_{OFF} , and thus to the input voltage V_{IN} . Fig. 11 shows the scheme to achieve the objective.

The PWM is performed by the intersection of a ramp signal with the averaged inductor current at pin 3 (I_{COMP}). The PWM cycle starts with the Gate turn off for a duration of $T_{OFF(MIN)}$ (350ns typ.) and the ramp is kept discharged. The ramp is then allowed to rise after $T_{OFF(MIN)}$ expires. The off time of the boost transistor ends at the intersection of the ramp signal and the averaged current waveform. This results in the proportional relationship between the average current and the off duty cycle D_{OFF} .

Fig. 12 shows the timing diagrams of $T_{OFF(MIN)}$ and the PWM waveforms.

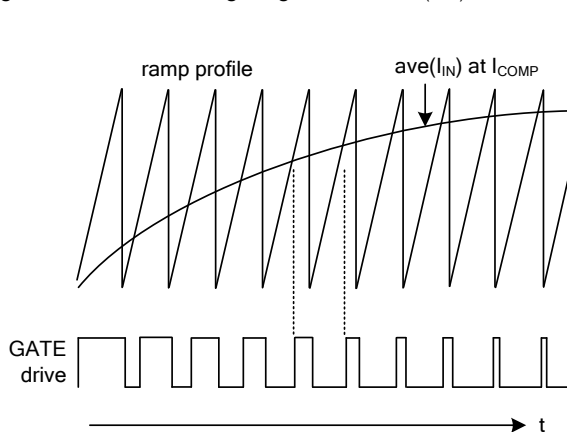

Fig. 11 Average Current Control in CCM

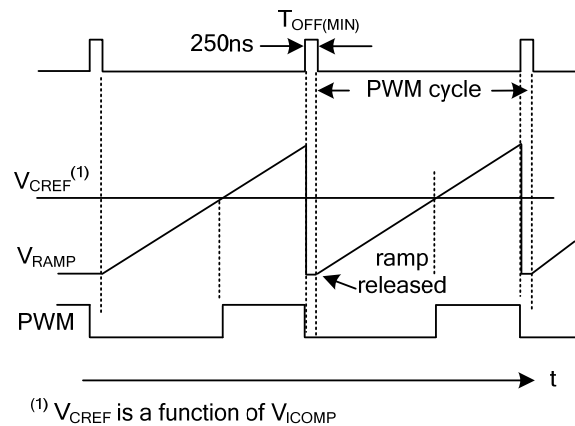

Fig. 12 Ramp and PWM Waveforms

6.4 Nonlinear Gain Block

The nonlinear gain block controls the amplitude of the regulated inductor current. The input of this block is the voltage at pin V_{COMP} . This block has been designed to support the wide input voltage range (85-265V_{AC}).

FUNCTIONAL DESCRIPTION(Cont.)

7. PWM Logic

The PWM logic block prioritizes the control input signals and generates the final logic signal to turn on the driver stage. The speed of the logic gates in this block, together with the width of the reset pulse $T_{OFF(MIN)}$, are designed to meet a maximum duty cycle D_{MAX} of 95% at the GATE output under 125kHz of operation.

In case of high input currents which result in Peak Current Limitation, the GATE will be turned off immediately and maintained in off state for the current PWM cycle. The signal $T_{OFF(MIN)}$ resets (highest priority, overriding other input signals) both the current limit latch and the PWM on latch as illustrated in Fig. 13.

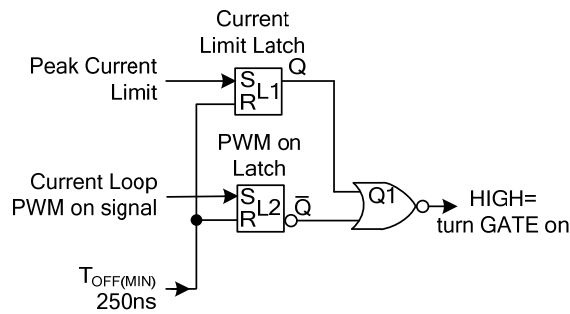

Fig. 13 PWM Logic

8. Voltage Loop

The voltage loop is the outer loop of the cascaded control scheme which controls the PFC output bus voltage V_{OUT} . This loop is closed by the feedback sensing voltage at V_{SENSE} which is a resistive divider tapping from V_{OUT} . The pin V_{SENSE} is the input of OTA1 which has an internal reference of 5V. Fig. 14 shows the important blocks of this voltage loop.

8.1 Voltage Loop Compensation

The compensation of the voltage loop is installed at the V_{COMP} pin (see Fig. 14). This is the output of OTA1 and the compensation must be connected at this pin to ground. The compensation is also responsible for the soft start function which controls an increasing AC input current during start-up.

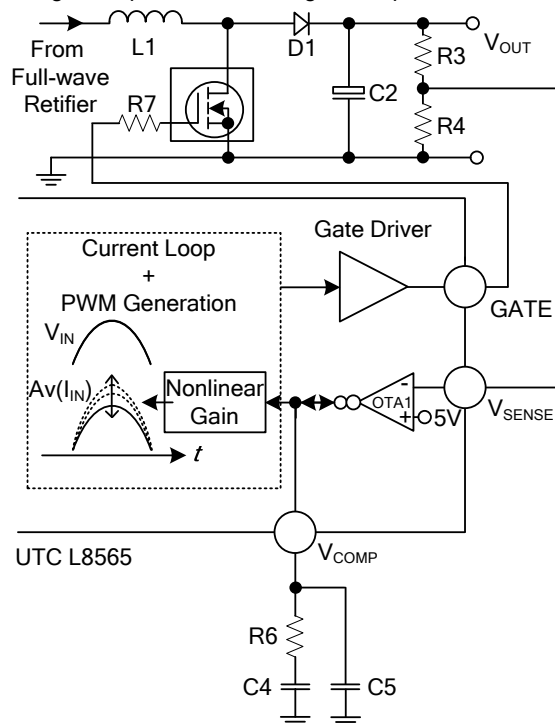

Fig. 14 Voltage Loop

■ FUNCTIONAL DESCRIPTION(Cont.)

8.2 Enhanced Dynamic Response

Due to the low frequency bandwidth of the voltage loop, the dynamic response is slow and in the range of about several 10ms. This may cause additional stress to the bus capacitor and the switching transistor of the PFC in the event of heavy load changes.

The IC provides therefore a “window detector” for the feedback voltage V_{VSENSE} at pin 1 (V_{SENSE}). Whenever V_{VSENSE} exceeds the reference value (5V) by $\pm 5\%$, it will act on the nonlinear gain block which in turn affect the gate drive duty cycle directly. This change in duty cycle is bypassing the slow changing V_{COMP} voltage, thus results in a fast dynamic response of V_{OUT} .

9. Output Gate Driver

The output gate driver is a fast totem pole gate drive. It has an in-built cross conduction currents protection and a Zener diode Z1 (see Fig. 15) to protect the external transistor switch against undesirable over voltages. The maximum voltage at pin 7 (GATE) is typically clamped at 11.5V.

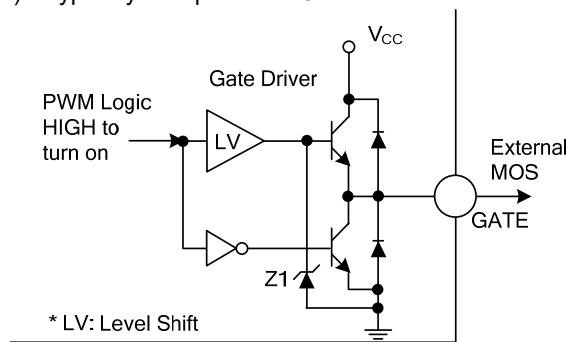

UTC L8565
Fig. 15 Gate Driver

The output is active HIGH and at V_{CC} voltages below the under voltage lockout threshold V_{CCUVLO} , the gate drive is internally pull low to maintain the off state.

■ TYPICAL APPLICATION CIRCUIT

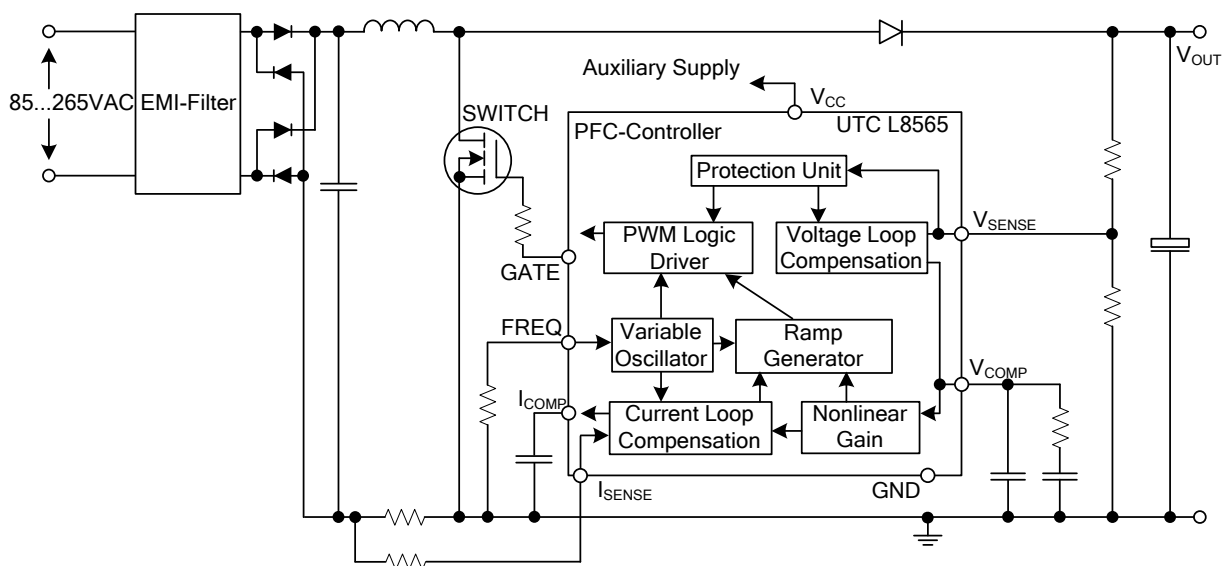

UTC assumes no responsibility for equipment failures that result from using products at values that exceed, even momentarily, rated values (such as maximum ratings, operating condition ranges, or other parameters) listed in products specifications of any and all UTC products described or contained herein. UTC products are not designed for use in life support appliances, devices or systems where malfunction of these products can be reasonably expected to result in personal injury. Reproduction in whole or in part is prohibited without the prior written consent of the copyright owner. UTC reserves the right to make changes to information published in this document, including without limitation specifications and product descriptions, at any time and without notice. This document supersedes and replaces all information supplied prior to the publication hereof.