



M4670

Advance

CMOS IC

FILTERLESS HIGH EFFICIENCY 3W SWITCHING AUDIO AMPLIFIER

DESCRIPTION

The **M4670** is a fully integrated single-supply, high-efficiency Class D switching audio amplifier, and it can provide 3W of output power. Containing adjustable output gain chip with micro-power shutdown mode, the **M4670** has innovative modulation schemes that eliminate the output filter wave devices and thus reduces the requirement of external components helping to streamline the circuit design and reduce board area.

By using delta-sigma modulation technique which handles incoming analog signal, the **M4670** can reduce the output noise and total harmonic distortion.

Operating on a single 5V supply, the **M4670** can be a continuous average output of 2.3W of power to driver the 4Ω speaker, and the total harmonic distortion and noise (THD+N) are less than 1%. High power conversion efficiency of the **M4670** can drive a larger load speaker that is respectively comparable to the typical Class AB amplifier. Its can be used with a 3.6V, 600mW power supply to driver an 8Ω speaker, while the efficiency is as high as 88%.

The **M4670** has a high output power characteristics that makes it ideal for ultra-high-power walkie-talkies, mobile phones, hands-free intercom systems and applications.

FEATURES

- * Externally Configurable Gain
- * No Output Filter Required for Inductive Loads
- * Very Fast Turn on Time: 1.05ms (Typical)
- * 'Click and Pop' Suppression Circuitry
- * Micro-Power Shutdown Mode
- * Short Circuit Protection

ORDERING INFORMATION

Ordering Number		Package	Packing
Lead Free	Halogen Free		
M4670L-K08-3030-R	M4670G-K08-3030-R	DFN3030-8	Tape Reel

<p>M4670G-K08-3030-R</p>	<p>(1) R: Tape Reel (2) K08-3030: DFN3030-8 (3) G: Halogen Free and Lead Free, L: Lead Free</p>
--------------------------	---

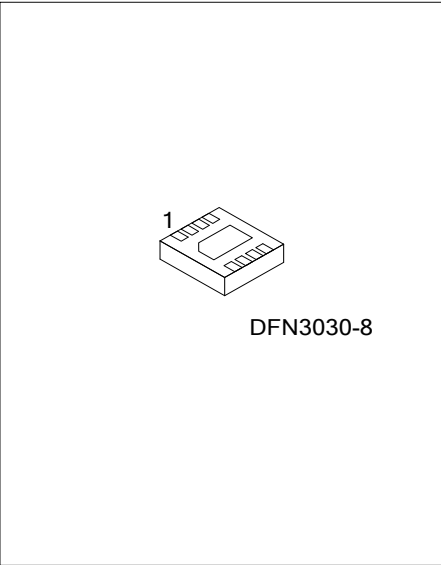

MARKING

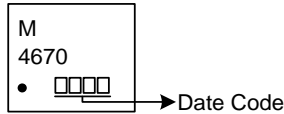

PIN CONFIGURATIONS

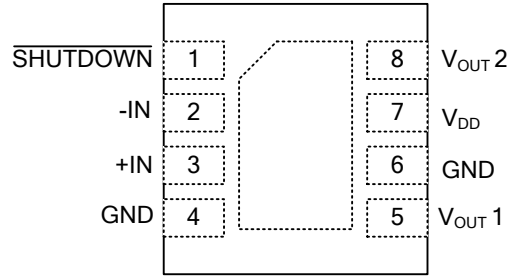

PIN DESCRIPTION

PIN NO	PIN NAME	PIN TYPE	PIN DESCRIPTION
1	SHUTDOWN	I	Enable input
2	-IN	I	Negative signal input
3	+IN	I	Positive signal input
4, 6	GND	I	Ground pin
5	V _{OUT1}	O	Output voltage pin
7	V _{DD}	I	Power supply input for internal circuitry
8	V _{OUT2}	O	Output voltage pin

BLOCK DIAGRAM

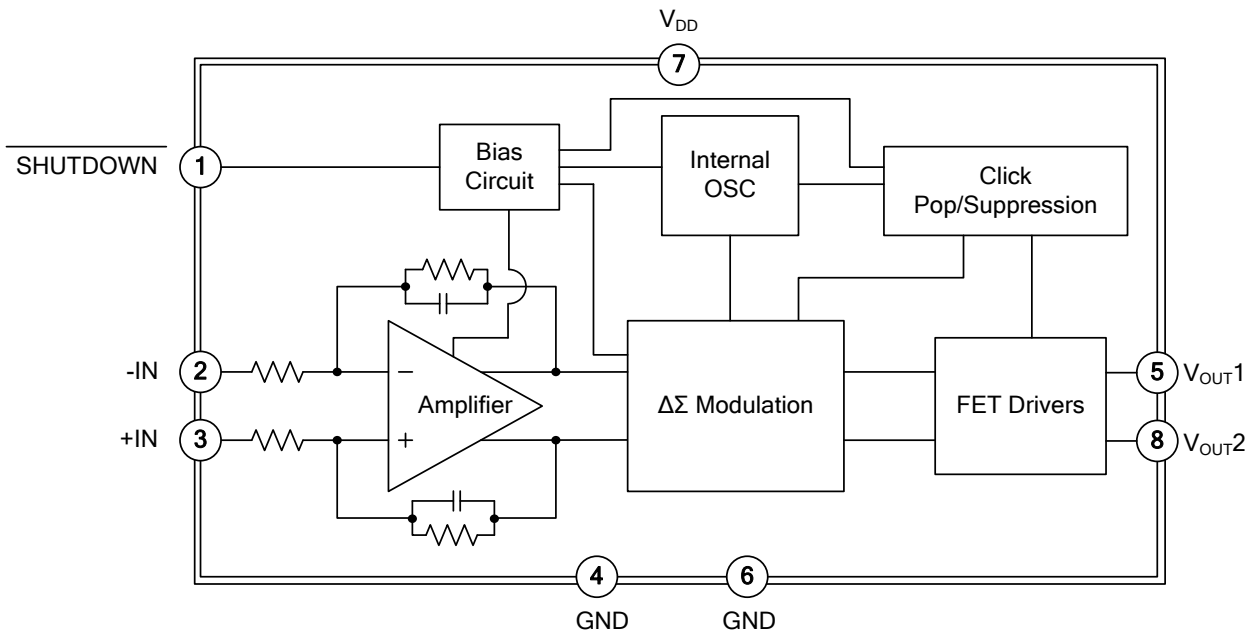

Fig. 1 Interior Configuration Circuit

■ ABSOLUTE MAXIMUM RATING

PARAMETER	SYMBOL	RATINGS	UNIT
Supply Voltage	V_{DD}	6	V
Voltage at any input pin		GND-0.3 ~ $V_{DD}+0.3$	V
Junction Temperature	T_J	+150	°C
Storage Temperature	T_{STG}	-65 ~ +150	°C

Note: Absolute maximum ratings are those values beyond which the device could be permanently damaged. Absolute maximum ratings are stress ratings only and functional device operation is not implied.

■ RECOMMENDED OPERATING CONDITIONS (Note)

PARAMETER	SYMBOL	RATINGS	UNIT
Supply Voltage	V_{DD}	2.4 ~ 5.5	V
Ambient Operating Temperature	T_{OPR}	-40 ~ +85	°C

Note: All voltage values are with respect to the network ground terminal unless otherwise noted.

■ THERMAL DATA

PARAMETER	SYMBOL	RATINGS	UNIT
Junction to Ambient	θ_{JA}	220	°C/W

■ ELECTRICAL CHARACTERISTICS

(The following specifications apply for $A_V=2V/V$ ($R_{IN}=150K\Omega$), $R_L = 15\mu H+8\Omega+15\mu H$, limits apply for $T_A=25^\circ C$, unless otherwise specified.)

PARAMETER	SYMBOL	TEST CONDITIONS	MIN	TYP	MAX	UNIT
Differential Output Offset Voltage	$ V_{OS} $	$V_{IN} = 0, A_V=2V/V, V_{DD}=2.4V$ to 5.0V			25	mV
GMS Power Supply Rejection Ratio	$PSRR_{GSM}$	$V_{DD}=2.4V$ to 5.0V, Input Referred		64		dB
GMS Common Mode Rejection Ratio	$CMRR_{GSM}$	$V_{DD}=2.4V$ to 5.0V $V_{IC}=V_{DD}/2$ to 0.5V $V_{IC}=V_{DD}/2$ to $V_{DD}-0.8V$ Input Referred		80		dB
Logic High Input Current	I_{IH}	$V_{DD} = 5.0V, V_{IN} = 5.8V$		20	100	μA
Logic Low Input Current	I_{IL}	$V_{DD} = 5.0V, V_{IN} = -0.3V$		1	5	μA
Quiescent Power Supply Current	I_{DD}	$V_{DD} = 5.0V, V_{IN} = 0V$, No Load		7.0	10	mA
		$V_{DD} = 3.6V, V_{IN} = 0V$, No Load		4.8		
		$V_{DD} = 2.4V, V_{IN} = 0V$		3.8	5	
Shutdown Current	I_{SD}	$V_{SHUTDOWN} = 0V, V_{DD} = 2.4V \sim 5V$		0.01	1	μA
Shutdown voltage input high	V_{SDIH}		1.4			V
Shutdown voltage input low	V_{SDIL}				0.4	V
Output Impedance	R_{OSD}	$V_{SHUTDOWN} = 0.4V$		>100		K Ω
Gain	A_V		270 K Ω/R_i	300 K Ω/R_i	330 K Ω/R_i	V/V
Resistance from Shutdown pin to GND	R_{SD}			300		K Ω

■ ELECTRICAL CHARACTERISTICS (Cont.)

PARAMETER	SYMBOL	TEST CONDITIONS	MIN	TYP	MAX	UNIT		
Output Power	Po	R _L =15μH+4Ω+15μH THD=10% (max) f=1KHz, 22KHz BW	V _{DD} =5V		3.0		W	
			V _{DD} =3.6V		1.5		W	
			V _{DD} =2.5V		675		mW	
		R _L =15μH+4Ω+15μH THD=1% (max) f=1KHz, 22KHz BW	Po	V _{DD} =5V		2.3		W
				V _{DD} =3.6V		1.2		W
				V _{DD} =2.5V		550		mW
		R _L =15μH+8Ω+15μH THD=10% (max) f=1KHz, 22KHz BW	Po	V _{DD} =5V		1.65		W
				V _{DD} =3.6V		850		mW
				V _{DD} =2.5V		400		mW
		R _L =15μH+8Ω+15μH THD=1% (max) f=1KHz, 22KHz BW	Po	V _{DD} =5V		1.35		W
				V _{DD} =3.6V	600	680		mW
				V _{DD} =2.5V		325		mW
Total Harmonic Distortion + Noise	THD+N	V _{DD} =5V, P _O =1 W _{RMS} , f=1KHz		0.35		%		
		V _{DD} =3.6V, P _O =0.5 W _{RMS} , f=1KHz		0.30				
		V _{DD} =3.6V, P _O =0.5 W _{RMS} , f=5KHz		0.30				
		V _{DD} =3.6V, P _O =0.5 W _{RMS} , f=10KHz		0.30				
Power Supply Rejection Ratio	PSRR	V _{DD} =3.6V, V _{RI} PPLE=200mV _{pp} Sine, f _{RI} PPLE=217Hz, Input to AC GND, C _I =0.1μ, Input Referred		68		dB		
		V _{DD} =3.6V, V _{RI} PPLE=200mV _{pp} Sine, f _{RI} PPLE=1KHz, Input to AC GND, C _{IN} =0.1μF, Input Referred		65				
		V _{DD} =3.6V, V _{RI} PPLE=200mV _{pp} Sine, f _{RI} PPLE=217Hz, f _{IN} =1KHz, P _O =10m W _{RMS} , Input Referred		62				
Signal to Noise Ratio	SNR	V _{DD} =5V, P _O =1 W _{RMS}		93		dB		
Output Noise	ε _{OUT}	V _{DD} =3.6V, f = 20Hz-20KHz Inputs to AC GND, C _{IN} =0.1μF, No Weighting, Input Referred		85		μV _{RMS}		
		V _{DD} =3.6V, Inputs to AC GND, C _{IN} =0.1μF, A Weighted Input Referred		65				
Common Mode Rejection Ratio	CMRR	V _{DD} =3.6V, V _{RI} PPLE=1V _{pp} Sine f _{RI} PPLE=217Hz, Input Referred		80		dB		
Wake-up Time	T _{WU}	V _{DD} =3.6V		1.35		ms		
Shutdown Time	T _{SD}	V _{DD} =3.6V		0.01		ms		

■ APPLICATION INFORMATION

GENERAL AMPLIFIER FUNCTION

The **M4670** output signal consists of two, BTL connected, of course, the output signal can also be a pulse signal, the minimum width of each pulse is approximately 350ns. The two outputs can pulse independently exception that they both may never pulse simultaneously as this would result in zero volts across the BTL load. But in the same row of as the output pulse occurred in this case, they are connected together, as a broader pulse, to achieve an effective 100% duty cycle occurs. For a given supply voltage and load impedance, the maximum audio output power effects. The **M4670** chip can achieve much high efficiencies than the class AB amplifier, while maintaining acceptable THD performance.

The short driver pulse output means, a good efficiency can be issued with the **M4670** inductive load. For the typical sensor load audio amplifier is a very passive. To this end, the load can act as its own filter.

POWER DISSIPATION AND EFFICIENCY

In general, efficiency is considered useful in the work required to produce a different power dissipated in the integrated circuit usually it is divided by the total energy output ratio. For audio systems, the energy delivered in the audible bands is considered useful including the distortion products of the input signal. Sub-sonic (DC) and super-sonic components (>22kHz) are not useful. The difference between the power flowing from the power supply and the audio band power being transduced is dissipated in the **M4670** and in the transducer load. The amount of power dissipation in the **M4670** is very low. This is because the on resistance of the switches used to form the output waveforms is typically less than 0.25Ω. This leaves only the transducer load as a potential "sink" for the small excess of input power over audio band output power. The **M4670** dissipates only a fraction of the excess power requiring no additional PCB area or copper plane to act as a heat sink.

DIFFERENTIAL AMPLIFIER EXPLANATION

The **M4670** is a fully differential amplifier with differential input and output stages. A differential amplifier amplifies the difference between the two input signals. Traditional audio power amplifiers have typically offered only single-ended inputs resulting in a 6dB reduction in signal to noise ratio relative to differential inputs. The **M4670** also provides the possibility of DC input coupling, eliminating the need for two external AC coupling, DC blocking capacitors. The **M4670** also can be used, but as a single-ended input amplifier while still retaining it is an entirely different interests. The main advantage of a differential amplifier is to increase common-mode rejection ratio (CMRR) for a single input amplifier.

SHUTDOWN FUNCTION

In order to reduce power consumption while not in use, the **M4670** contains shutdown circuit current consumption reduced to less than the reduced 0.01μA. For the closure of trigger point is displayed as a table of electrical characteristics and typical shutdown hysteresis voltage diagram found in some of the typical performance characteristics. The best is to switch on the ground and use the smallest current supply, while in the closed state. The **M4670** may be disabled chip off the ground and supply voltage, the idle current is larger than the typical value of reduced 0.01μA. Total harmonic distortion may increase, but also can be observed when the voltage is less than the diameter of the shutdown pin in PLAY mode.

There has a resistor connected between GND and Shutdown pins in the **M4670** internal, and this resistor is designed to eliminate any unnecessary state changes, when the Shutdown pin is floating. To minimize the supply current when the **M4670** working in the Shutdown mode, if the **M4670** don't working in the Shutdown mode, the amount of additional resistor current due to the internal shutdown resistor can be found be Equation (1) below.

$$(V_{SD} - GND) / 300k\Omega \quad (1)$$

The difference is only 0.5V, the current additional 1.7μA, lots will be drawn, while in the closed state.

■ APPLICATION INFORMATION (Cont.)

PROPER SELECTION OF EXTERNAL COMPONENTS

The M4670's gain is set by the external resistors Ri, shown in Fig. 2, the gain of the equation by (2) is given. When the gain of 2V/V (6dB), the THD+N performance of the best.

$$AV = 2 * 150 \text{ k}\Omega / Ri \text{ (V/V) (2)}$$

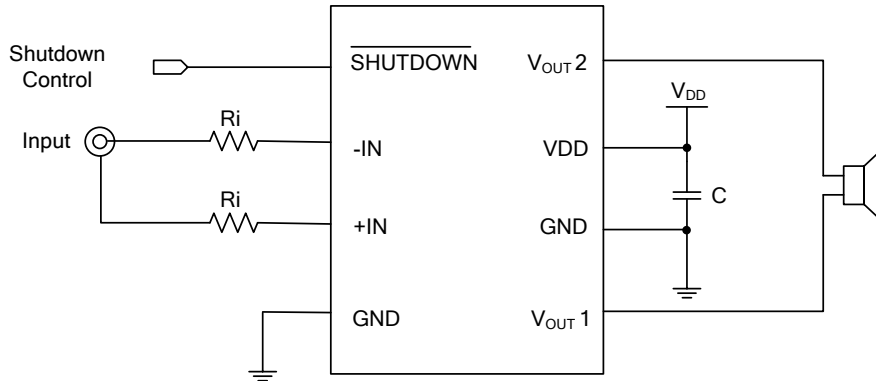

Fig. 2 Typical Audio Amplifier Application Circuit

We recommend an external resistor Ri of the error within 1%, and the resistance should be close to M4670 input pins to keep two symmetrical inputs, which will help improve the M4670 noise suppression due to the good CMRR of the M4670. Noise coupled onto input traces which are physically close to each other will be common mode and easily rejected by the M4670. Input capacitors may be needed for some applications or when the source is single-ended (Fig. 4, 6). Input capacitors are needed to block any DC voltage at the source so that the DC voltage seen between the input terminals of the M4670 is 0V. Input capacitors create a high-pass filter with the input resistors, Ri. The -3dB point of the high-pass filter is found using Equation (3) below.

$$f_c = 1 / (2\pi Ri Ci) \text{ (Hz) (3)}$$

Of course, the input capacitors can also be used to remove the low audio frequencies. When using the M4670 single-ended source, power supply noise on the ground is a +IN input pin capacitance-coupled input signals are on the ground (Fig. 6~8). Setting the high-pass filter point above the power supply noise over the frequency of 217Hz in the GSM mobile phone.

DIFFERENTIAL CIRCUIT CONFIGURATIONS

The M4670 can be used in many different circuit configurations. The most typical is the DC-coupled, differential input configuration shown in Fig. 3. Equation(2) above is used to determine the value of the Ri resistors for a desired gain.

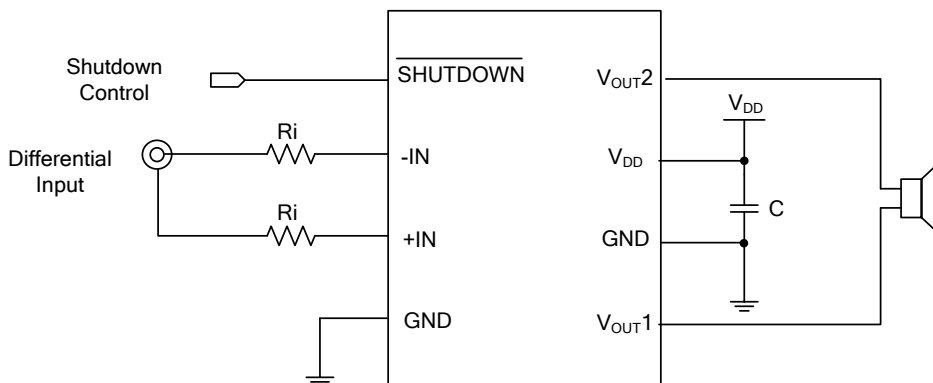

Fig. 3 Differential Input Configuration

■ APPLICATION INFORMATION (Cont.)

Input capacitors can be used in a differential configuration as shown in Fig. 4. Equation (3) above is used to determine the value of the C_i capacitors for a desired frequency, Equation (2) above is used to determine the value of the R_i resistors for a desired gain.

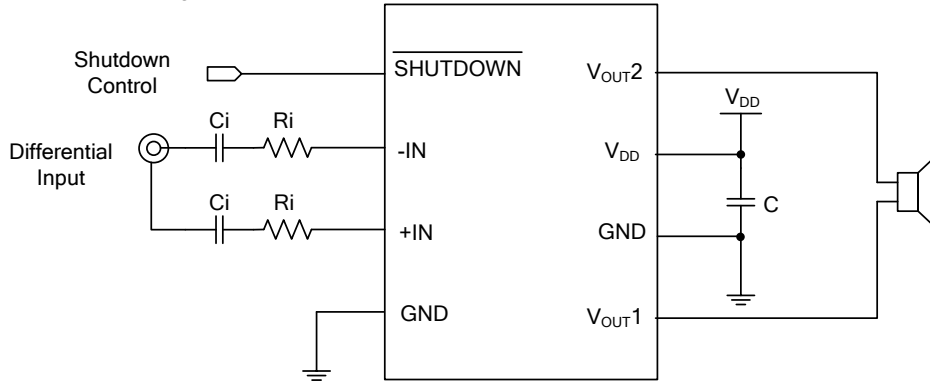

Fig. 4 Differential Input Configuration with capacitors

The M4670 can be used for amplification of multiple audio sources. The application configuration as shown in Fig. 5. Each input gain can be independently set the maximum use of each input and the design equation (2) on the R_i resistors of flexibility. Input capacitance can be used with one or more than one source, as well as the different frequency response according to the source or DC voltage, if necessary from the source block.

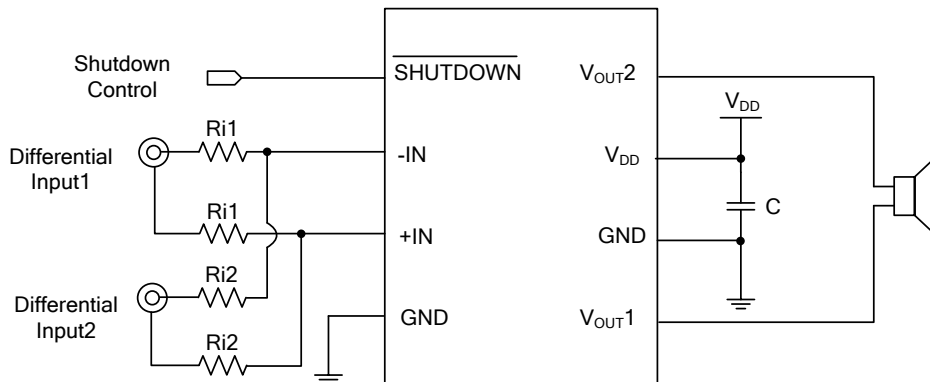

Fig. 5 Dual Differential Input Configuration

SINGLE-ENDED CIRCUIT CONFIGURATIONS

The M4670 can be used for single-ended input capacitance of the source, but will need to enter the terminal to prevent any DC. For the gain equations, Equation (2), frequency response, Equation (3), the typical application configuration as shown in Fig. 6.

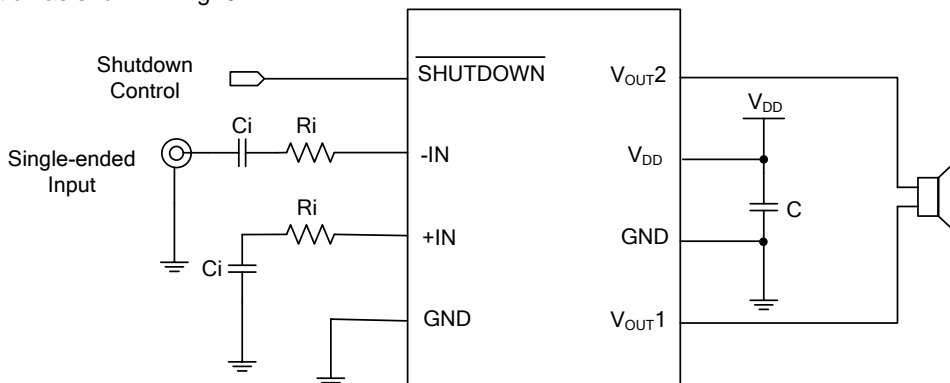

Fig. 6 Single-ended Input Configuration

■ APPLICATION INFORMATION (Cont.)

If the input signal as shown in Fig. 7, the equivalent impedance of each input should be equal. To find the correct values for Ci3 and Ri3, which are found by calculating the parallel combination of all Ci values and all Ri values. Equations (4) and (5) below are for any number of single-ended sources.

$$C_{i3} = C_{i1} + C_{i2} + C_{in} \dots (f) \quad (4)$$

$$R_{i3} = 1 / (1/R_{i1} + 1/R_{i2} + 1/R_{in} \dots)(\Omega) \quad (5)$$

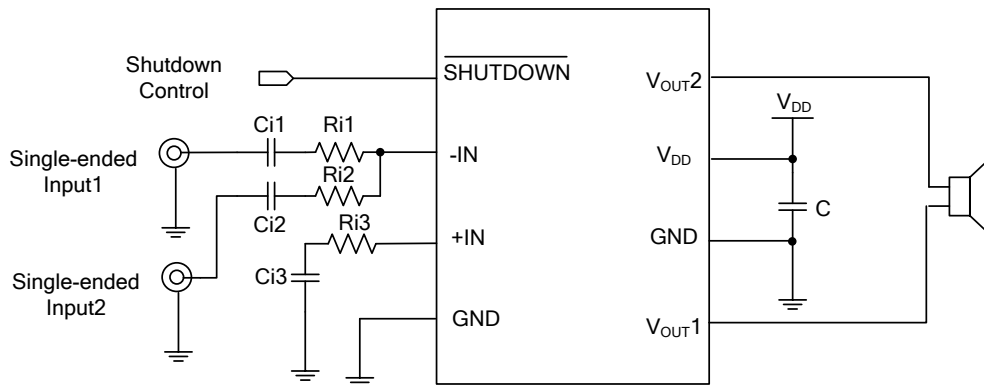

Fig. 7 Dual Single-ended Input Configuration

The M4670 also can use a combination of single-ended and differential sources. A typical application with one single-ended source and one differential source is shown in Fig. 8. The use of superposition principle, the external component values can be determined according to the configuration of the above equations(4)(5).

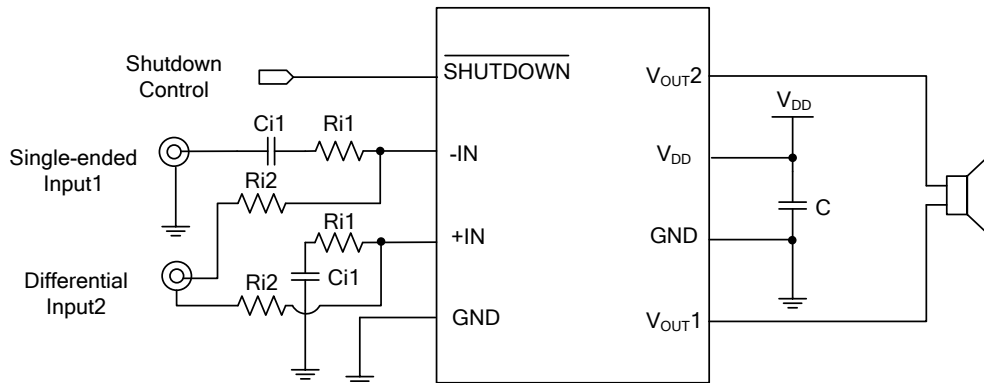

Fig. 8 Dual Input with a Single-ended Input and a Differential Input

UTC assumes no responsibility for equipment failures that result from using products at values that exceed, even momentarily, rated values (such as maximum ratings, operating condition ranges, or other parameters) listed in products specifications of any and all UTC products described or contained herein. UTC products are not designed for use in life support appliances, devices or systems where malfunction of these products can be reasonably expected to result in personal injury. Reproduction in whole or in part is prohibited without the prior written consent of the copyright owner. UTC reserves the right to make changes to information published in this document, including without limitation specifications and product descriptions, at any time and without notice. This document supersedes and replaces all information supplied prior to the publication hereof.