



## U74AHC1G06

CMOS IC

### INVERTER WITH OPEN-DRAIN OUTPUT

#### DESCRIPTION

The UTC **U74AHC1G06** is an inverter with open-drain output and it provides the Function  $Y = \overline{A}$ .

#### FEATURES.

- \* Operation Voltage Range: 2V~5.5V
- \* High noise immunity
- \* Low Power Dissipation

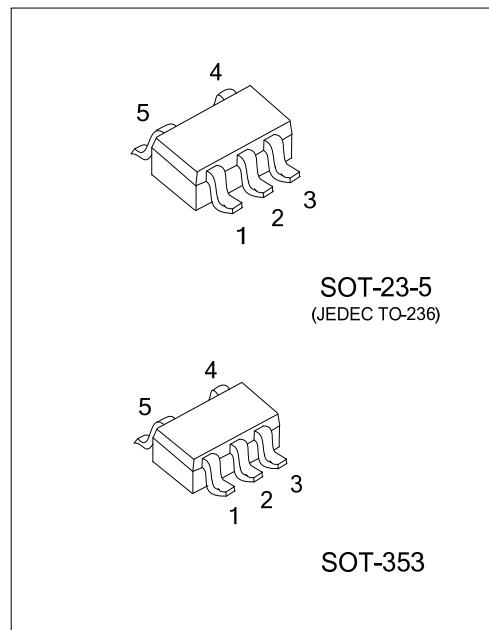

#### ORDERING INFORMATION

Ordering Number		Package	Packing
Lead Free	Halogen Free		
U74AHC1G06L-AE5-R	U74AHC1G06G-AE5-R	SOT-23-5	Tape Reel
U74AHC1G06L-AL5-R	U74AHC1G06G-AL5-R	SOT-353	Tape Reel

<p>U74AHC1G06G-AE5-R</p> <p>(1) Packing Type</p> <p>(2) Package Type</p> <p>(3) Green Package</p>	<p>(1) R: Tape Reel</p> <p>(2) AE5: SOT-23-5, AL5: SOT-353</p> <p>(3) G: Halogen Free and Lead Free, L: Lead Free</p>
---	---

#### MARKING

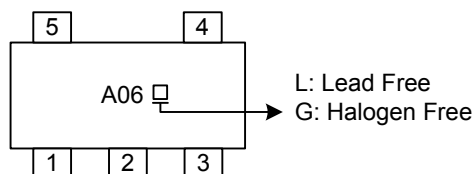

## ■ PIN CONFIGURATION

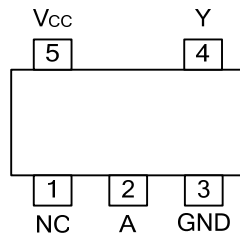

## ■ FUNCTION TABLE

INPUT A	OUTPUT Y
H	L
L	Z

Note: H: High Voltage Level  
L: Low Voltage Level  
Z: High-Impedance OFF-State

## ■ LOGIC DIAGRAM

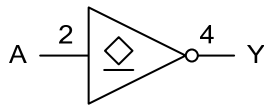

Logic symbol

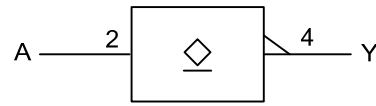

IEC logic symbol

■ ABSOLUTE MAXIMUM RATING (unless otherwise specified)

PARAMETER	SYMBOL	RATINGS	UNIT
Supply Voltage	$V_{CC}$	-0.5 ~ +7.0	V
Input Voltage	$V_{IN}$	-0.5 ~ +7.0	V
Input Clamp Current ( $V_{IN} < -0.5V$ )	$I_{IK}$	-20	mA
Output Clamp Current ( $V_{OUT} < -0.5V$ ) (Note 2)	$I_{OK}$	±20	mA
Output Current ( $V_{OUT} > -0.5V$ )	$I_{OUT}$	±25	mA
$V_{CC}$ or GND Current	$I_{CC}$	±75	mA
Power Dissipation	$P_D$	250	mW
Derate above $T_A > 87.5^\circ C$		4.0	mW/K
Operating Temperature	$T_{OPR}$	-40 ~ +125	°C
Storage Temperature	$T_{STG}$	-65 ~ +150	°C

Notes: 1. Absolute maximum ratings are those values beyond which the device could be permanently damaged.

Absolute maximum ratings are stress ratings only and functional device operation is not implied.

2. The input and output voltage ratings may be exceeded if the input and output current ratings are observed.

■ RECOMMENDED OPERATING CONDITIONS

PARAMETER	SYMBOL	CONDITIONS	MIN	TYP	MAX	UNIT
Supply Voltage	$V_{CC}$		2.0		5.5	V
Input Voltage	$V_{IN}$		0		5.5	V
Output Voltage	$V_{OUT}$		0		$V_{CC}$	V
Input Transition Rise or Fall Rate	$\Delta t/\Delta v$	$V_{CC}=3.3+0.3V$			100	ns/V
		$V_{CC}=5.0+0.5V$			20	ns/V

■ STATIC CHARACTERISTICS ( $T_A=25^\circ C$ )

PARAMETER	SYMBOL	TEST CONDITIONS	MIN	TYP	MAX	UNIT
High-Level Input Voltage	$V_{IH}$	$V_{CC}=2.0V$	1.5			V
		$V_{CC}=3.0V$	2.1			V
		$V_{CC}=5.5V$	3.85			V
Low-Level Input Voltage	$V_{IL}$	$V_{CC}=2.0V$			0.5	V
		$V_{CC}=3.0V$			0.9	V
		$V_{CC}=5.5V$			1.65	V
Low-Level Output Voltage	$V_{OL}$	$V_{CC}=2.0V$			0.1	V
		$V_{CC}=3.0V$			0.1	V
		$V_{CC}=4.5V$			0.1	V
		$V_{CC}=3.0V, I_{OL}=4mA$			0.36	V
		$V_{CC}=4.5V, I_{OL}=8mA$			0.36	V
Input Leakage Current	$I_{I(LEAK)}$	$V_{CC}=0\sim 5.5V, V_{IN}=V_{CC}$ or GND			±0.1	µA
3-state output OFF-state current	$I_{OZ}$	$V_{CC}=5.5V, V_{IN}=V_{IH}$ or $V_{IL}, V_{OUT}=V_{CC}$ or GND			±0.25	µA
Quiescent Supply Current	$I_{CC}$	$V_{CC}=5.5V, V_{IN}=V_{CC}$ or GND, $I_{OUT}=0A$			1.0	µA
Input Capacitance	$C_{IN}$	$V_{IN}=V_{CC}$ or GND		1.5	10	pF

■ DYNAMIC CHARACTERISTICS (Input:  $t_{R}, t_{F} \leq 3ns; PRR \leq 1MHz, T_A=25^\circ C$ )

PARAMETER	SYMBOL	TEST CONDITIONS	MIN	TYP	MAX	UNIT	
Propagation delay from input (A) to output (Y)	$t_{PZL}$	$V_{CC}=3.3\pm 0.3V$	$C_L=15pF$		3.7	7.0	ns
			$C_L=50pF$		5.2	10.0	ns
			$C_L=15pF$		4.8	6.4	ns
			$C_L=50pF$		6.9	10.0	ns
	$t_{PLZ}$	$V_{CC}=5\pm 0.5V$	$C_L=15pF$		2.7	4.9	ns
			$C_L=50pF$		3.8	7.0	ns
			$C_L=15pF$		3.0	4.1	ns
			$C_L=50pF$		4.3	6.5	ns

## ■ TEST CIRCUIT AND WAVEFORMS

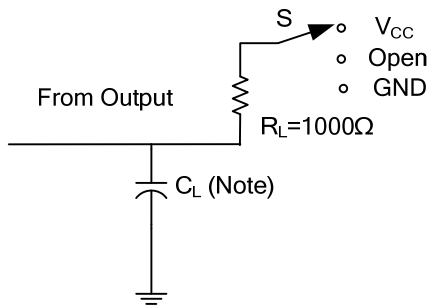

TEST	S
$t_{PLH}/t_{PHL}$	Open
$t_{PHZ}/t_{PZH}$	GND
$t_{PLZ}/t_{PZL}$	$V_{CC}$

TEST CIRCUIT

Note:  $C_L$  includes probe and jig capacitance.

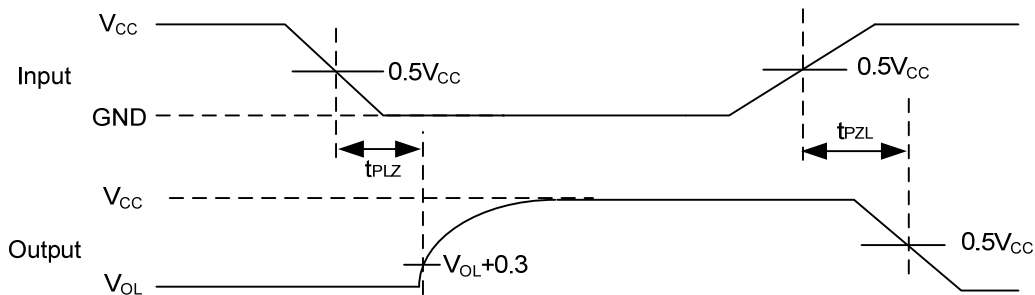

PROPAGATION DELAY TIMES

UTC assumes no responsibility for equipment failures that result from using products at values that exceed, even momentarily, rated values (such as maximum ratings, operating condition ranges, or other parameters) listed in products specifications of any and all UTC products described or contained herein. UTC products are not designed for use in life support appliances, devices or systems where malfunction of these products can be reasonably expected to result in personal injury. Reproduction in whole or in part is prohibited without the prior written consent of the copyright owner. UTC reserves the right to make changes to information published in this document, including without limitation specifications and product descriptions, at any time and without notice. This document supersedes and replaces all information supplied prior to the publication hereof.