



TF212

JFET

CAPACITOR MICROPHONE APPLICATIONS

DESCRIPTION

The UTC **TF212** uses advanced trench technology to provide excellent $R_{DS(ON)}$, low gate charge and operation with low gate voltages. This device is suitable for use in capacitor microphone applications.

FEATURES

- * Suited for use in audio, telephone capacitor microphones.
- * Good voltage characteristic.
- * Good transient characteristic.

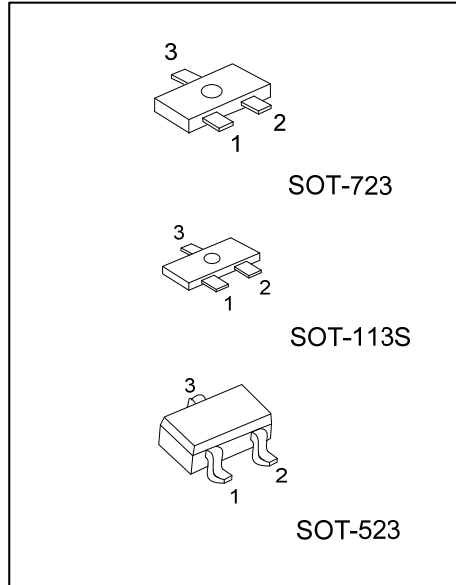

ORDERING INFORMATION

Ordering Number		Package	Pin Assignment			Packing
Lead Free	Halogen Free		1	2	3	
TF212L-xx-A3C-R	TF212G-xx-A3C-R	SOT-113S	D	S	G	Tape Reel
TF212L-xx-AN3-R	TF212G-xx-AN3-R	SOT-523	D	S	G	Tape Reel
TF212L-xx-AQ3-R	TF212G-xx-AQ3-R	SOT-723	D	S	G	Tape Reel

Note: Pin Assignment: D: Drain S: Source G: Gate

<p>TF212G-xx-AC3-R</p>	<p>(1) R: Tape Reel (2) A3C: SOT-113S, AN3: SOT-523, AQ3: SOT-723 (3) x: refer to Classification of I_{DSS} (4) G: Halogen Free and Lead Free, L: Lead Free</p>
------------------------	---

MARKING

TF212-F4	TF212-F5

■ ABSOLUTE MAXIMUM RATINGS ($T_A=25^{\circ}\text{C}$, unless otherwise specified)

PARAMETER	SYMBOL	RATING	UNIT
Gate Drain Voltage	V_{GDO}	-20	V
Gate Current	I_G	10	mA
Drain Current	I_D	1	mA
Power Dissipation	P_D	100	mW
Junction Temperature	T_J	+150	$^{\circ}\text{C}$
Storage Temperature	T_{STG}	-55 ~ +150	$^{\circ}\text{C}$

Note: Absolute maximum ratings are those values beyond which the device could be permanently damaged. Absolute maximum ratings are stress ratings only and functional device operation is not implied.

■ ELECTRICAL CHARACTERISTICS ($T_A=25^{\circ}\text{C}$, unless otherwise specified)

PARAMETER	SYMBOL	TEST CONDITIONS	MIN	TYP	MAX	UNIT
Gate Drain Breakdown Voltage	BV_{GDO}	$I_G=-100\mu\text{A}$	-20			V
Gate Source Cut off Voltage	$V_{GS(OFF)}$	$V_{DS}=5\text{V}, I_D=1\mu\text{A}$	-0.2	-0.6	-1.2	V
Drain Current	I_{DSS}	$V_{DS}=5\text{V}, V_{GS}=0$	140		350	μA
Forward Transfer Admittance	Y_{FSI}	$V_{DS}=2\text{V}, V_{GS}=0, f=1\text{KHz}$	1	1.2		mS
Input Capacitance	C_{ISS}	$V_{DS}=5\text{V}, V_{GS}=0, f=1\text{MHz}$		3.5		pF
Output Capacitance	C_{RSS}	$V_{DS}=5\text{V}, V_{GS}=0, f=1\text{MHz}$		0.65		pF
Voltage Gain	G_V	$V_{IN}=10\text{mV}, f=1\text{KHz}$		-3		dB
Reduced Voltage Characteristic	ΔG_{VV}	$V_{IN}=10\text{mV}, f=1\text{KHz}, V_{CC}=4.5\text{V} \rightarrow 1.5\text{V}$		-1.2	-3.5	dB
Frequency Characteristic	ΔG_{Vf}	$f=1\text{KHz to } 110\text{Hz}$			-1	dB
Input Resistance	Z_{IN}	$f=1\text{KHz}$	25			M Ω
Output Resistance	Z_O	$f=1\text{KHz}$			700	Ω
Total Harmonic distortion	THD	$V_{IN}=30\text{mV}, f=1\text{KHz}$		1		%
Output Noise Voltage	V_{NO}	$V_{IN}=0$			-110	dB

■ CLASSIFICATION OF I_{DSS}

RANK	F4	F5
RANGE	140-240	210-350

■ TEST CIRCUIT ($T_A=25^\circ\text{C}$, unless otherwise specified)

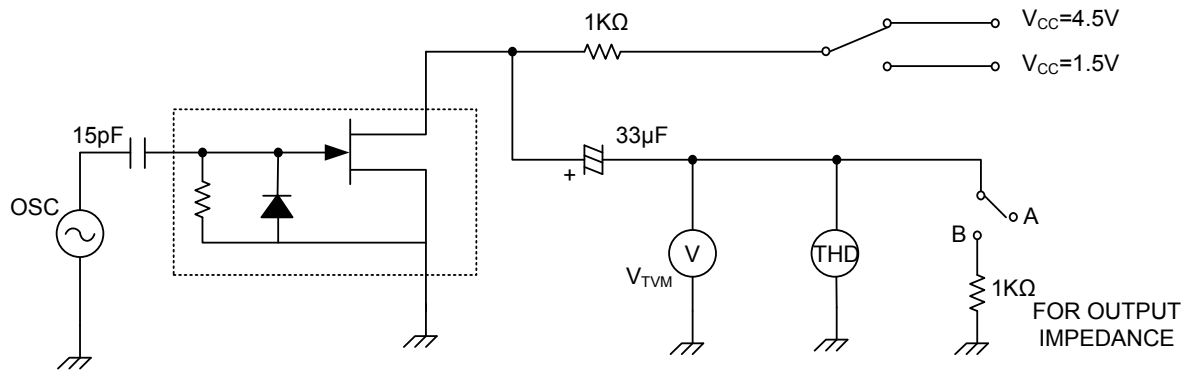

■ TYPICAL CHARACTERISTICS

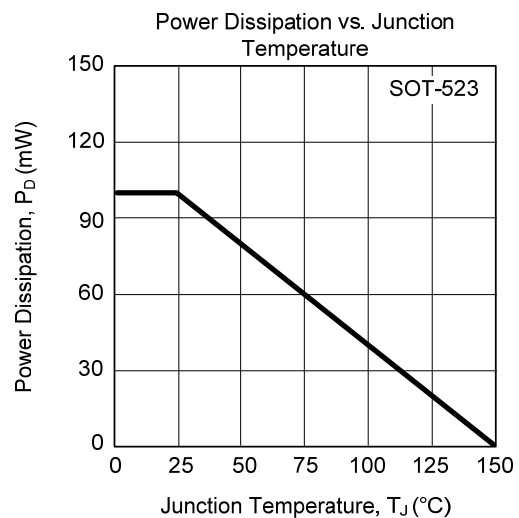
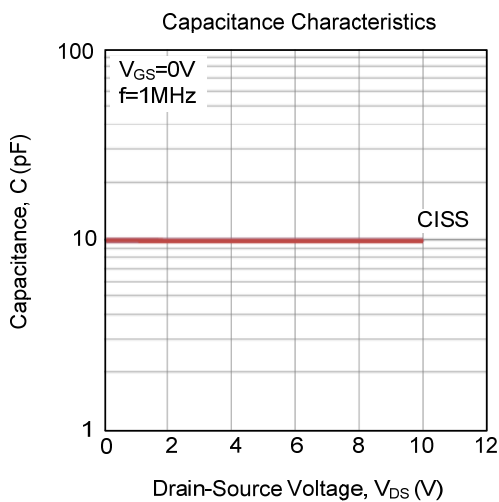
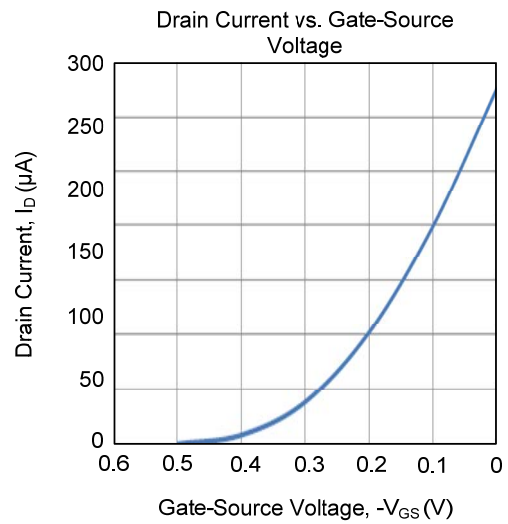
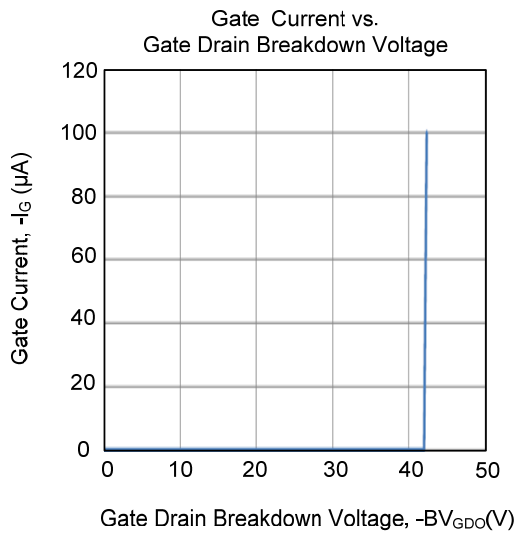
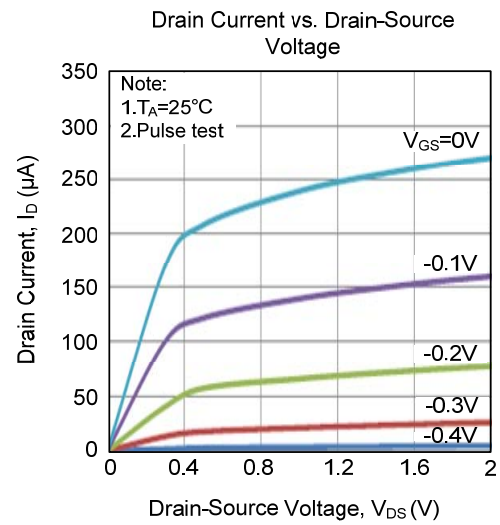
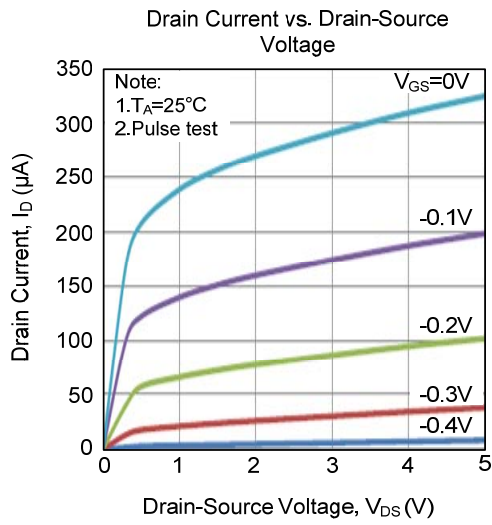

UTC assumes no responsibility for equipment failures that result from using products at values that exceed, even momentarily, rated values (such as maximum ratings, operating condition ranges, or other parameters) listed in products specifications of any and all UTC products described or contained herein. UTC products are not designed for use in life support appliances, devices or systems where malfunction of these products can be reasonably expected to result in personal injury. Reproduction in whole or in part is prohibited without the prior written consent of the copyright owner. UTC reserves the right to make changes to information published in this document, including without limitation specifications and product descriptions, at any time and without notice. This document supersedes and replaces all information supplied prior to the publication hereof.