



SR2803

LINEAR INTEGRATED CIRCUIT

330KHZ, 3A SYNCHRONOUS BUCK CONTROLLER

DESCRIPTION

The UTC **SR2803** is a synchronous buck regulator. The device provides 3A of continuous load current over a wide input voltage of 4V~28V. Current mode control provides fast transient response and cycle by cycle current limit. Integrates soft start, and shutdown mode.

The UTC **SR2803** can provide low-ripple power, high efficiency, and perfect transient characteristics. The duty ratio varies linearly from 0% to 92% in the PWM control. The error amplifier circuit and soft-start circuit included in this device can prevent overshoot at startup. An enable function, an over current protect (OCP) function and short circuit protect (SCP) are also build inside, and when OCP happens, the operation frequency will be reduced.

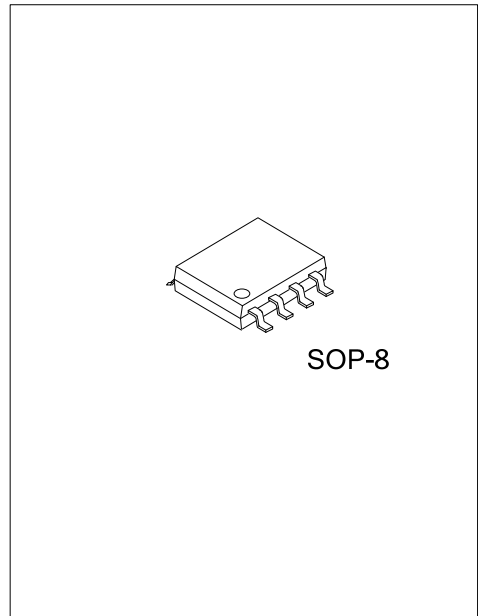

FEATURES

- * Input voltage varies from 4V ~ 28V
- * Output voltage varies from 0.82V to V_{CC}
- * Duty ratio varies from 0% to 92% PWM control
- * With 330kHz typical oscillation frequency
- * Thermal shutdown and SCP function and soft-start, current limit, enable function
- * Low ESR output capacitor(Multi-layer chip capacitor) application

ORDERING INFORMATION

Ordering Number		Package	Packing
Lead Free	Halogen Free		
SR2803L-S08-R	SR2803G-S08-R	SOP-8	Tape Reel

<p>SR2803G-S08-R</p> <ul style="list-style-type: none"> (1) Packing Type (2) Package Type (3) Green Package 	<ul style="list-style-type: none"> (1) R: Tape Reel (2) S08: SOP-8 (3) G: Halogen Free and Lead Free
--	---

MARKING

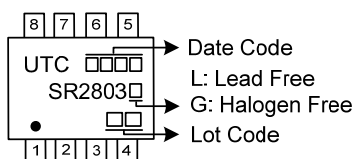

PIN CONFIGURATION

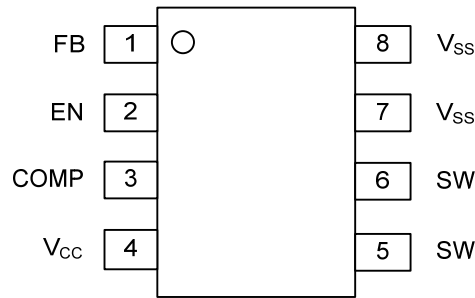

PIN DESCRIPTION

PIN NO.	PIN NAME	DESCRIPTION
1	FB	Feedback pin
2	EN	Power-off pin H: normal operation (Step-down) L: Step-down operation stopped (All circuits deactivated)
3	COMP	Compensation pin
4	V _{CC}	IC power supply pin
5	SW	Switch pin. Connect external inductor here.
6	SW	Switch pin. Connect external inductor here.
7	V _{SS}	GND pin
8	V _{SS}	GND pin

BLOCK DIAGRAM

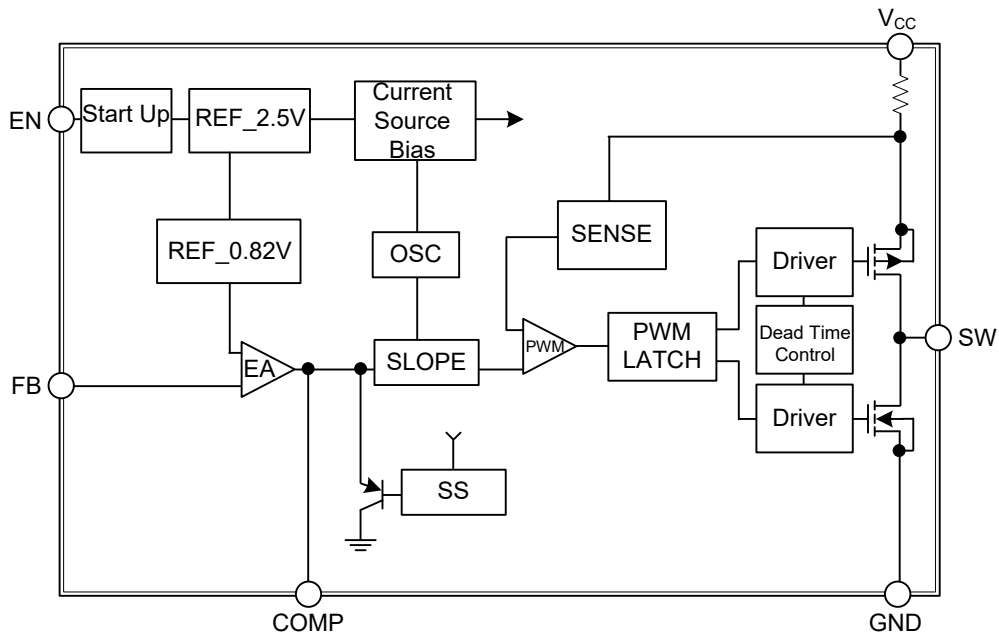

■ ABSOLUTE MAXIMUM RATING (T_A=25°C, unless otherwise specified)

PARAMETER	SYMBOL	RATINGS	UNIT
V _{CC} Pin Voltage	V _{CC}	V _{SS} -0.3 ~ V _{SS} +28	V
Feedback Pin Voltage	V _{FB}	V _{SS} -0.3 ~ V _{CC}	V
ON/OFF Pin Voltage	V _{EN}	V _{SS} -0.3 ~ V _{CC} +0.3	V
Switch Pin Voltage	V _{SW}	V _{SS} -0.3 ~ V _{CC} +0.3	V
Operating Supply Voltage	V _{OP}	+4 ~ 28	V
Power Dissipation	P _D	Internally limited	
Storage Temperature	T _{STG}	-40 ~ +150	°C
Operating Temperature	T _{OPR}	-20 ~ +125	°C

Note: Absolute maximum ratings are those values beyond which the device could be permanently damaged. Absolute maximum ratings are stress ratings only and functional device operation is not implied.

■ THERMAL DATA

PARAMETER	SYMBOL	RATINGS	UNIT
Junction to Ambient	θ _{JA}	70	°C/W
Junction to Case	θ _{JC}	25	°C/W

Note: θ_{JA} is measured with the PCB copper area(need connect to SW pins) of approximately 1 in²(Multi-layer)

■ ELECTRICAL CHARACTERISTICS (V_{IN}=12V, T_A=25°C, unless otherwise specified)

PARAMETER	SYMBOL	TEST CONDITIONS	MIN	TYP	MAX	UNIT
Feedback Voltage	V _{FB}	I _{OUT} =0.2A	0.80	0.82	0.84	V
Feedback Bias Current	I _{FB(BIAS)}	I _{OUT} =0.1A		0.1	0.5	μA
Switch Current	I _{SW}	Peak current, No outside circuit V _{FB} =0V Force driver on	3.5			A
Standby Current	I _{STN-BY}	V _{EN} =0V No outside circuit V _{FB} =0V Force driver on		2	10	μA
Quiescent Current	I _Q	V _{FB} =1.2V Force driver off		3	5	mA
Oscillation Frequency	f _{OSC}	Measure waveform at SW Pin	260	330	400	KHz
Frequency of Current Limit or Short Circuit Protect	f _{OSC1}	Measure waveform at SW Pin	20	40		KHz
Line Regulation	$\frac{\Delta V_{OUT}}{V_{OUT}}$	V _{CC} =5V-28V, I _{OUT} =0.2A		0.4		%
Load Regulation	$\frac{\Delta V_{OUT}}{V_{OUT}}$	I _{OUT} =0.2A-3A		0.3		%
EN Pin Input Current	I _{SH}	V _{EN} =2.5V(ON)		5		μA
	I _{SL}	V _{EN} =0.3V(OFF)		0		μA
Soft-Start Time	T _{SS}		0.3	3.5	8	ms
Internal MOSFET R _{DS(ON)}	R _{DS(ON)}	High-side Switch, I _{SW} =1A		70		mΩ
		low-side Switch, I _{SW} =1A		50		mΩ
EN Pin Logic input threshold voltage	V _{SH}	High(regulator ON)	1.6			V
	V _{SL}	Low(regulator OFF)			0.8	V
Thermal shutdown Temp	TSD			150		°C

■ TYPICAL APPLICATION CIRCUIT

MLCC

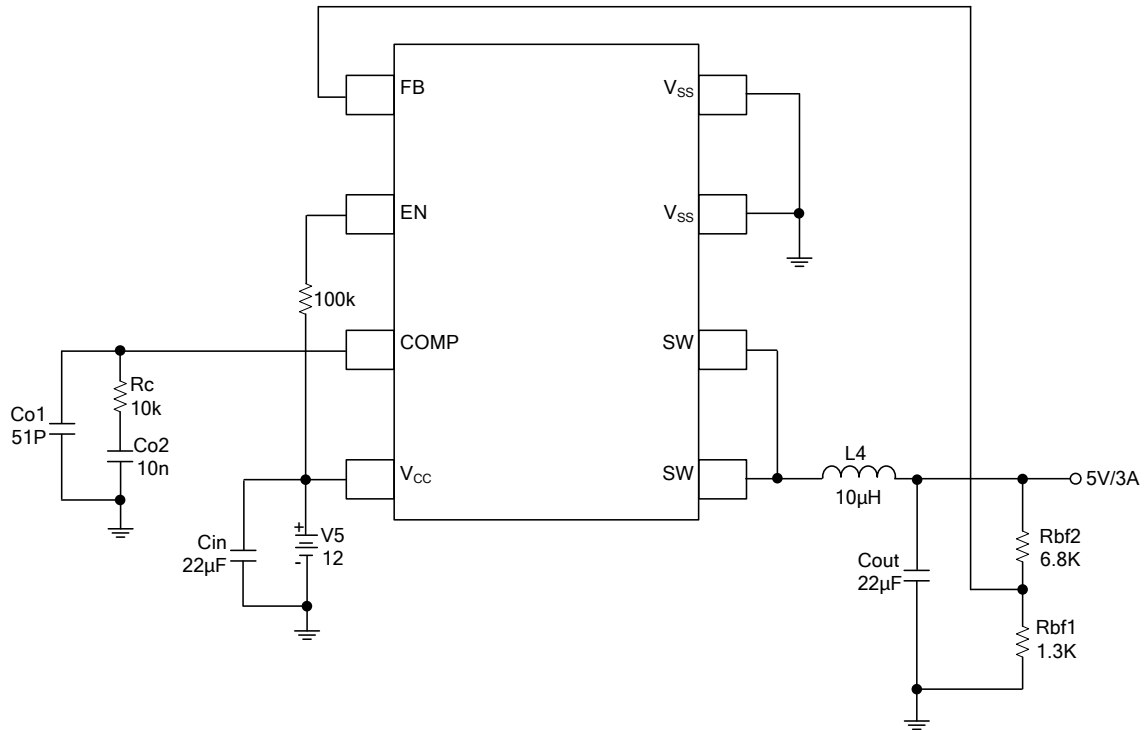

■ TYPICAL CHARACTERISTICS

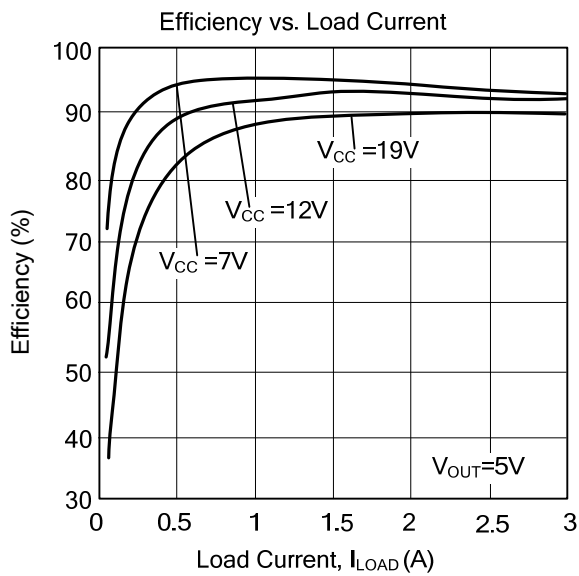
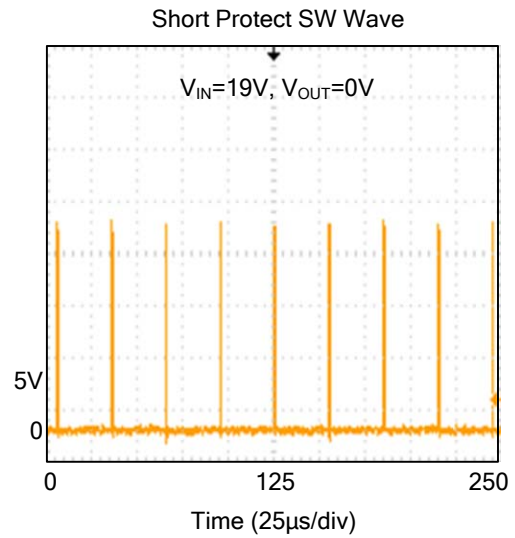
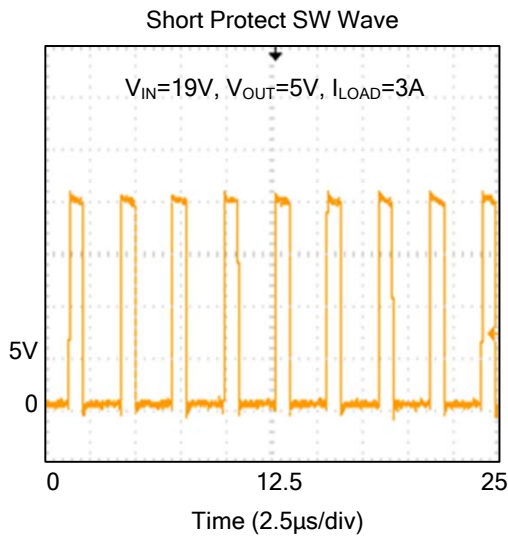

UTC assumes no responsibility for equipment failures that result from using products at values that exceed, even momentarily, rated values (such as maximum ratings, operating condition ranges, or other parameters) listed in products specifications of any and all UTC products described or contained herein. UTC products are not designed for use in life support appliances, devices or systems where malfunction of these products can be reasonably expected to result in personal injury. Reproduction in whole or in part is prohibited without the prior written consent of the copyright owner. UTC reserves the right to make changes to information published in this document, including without limitation specifications and product descriptions, at any time and without notice. This document supersedes and replaces all information supplied prior to the publication hereof.