



U74LVC2G86

CMOS IC

DUAL 2-INPUT EXCLUSIVE-OR GATE

DESCRIPTION

The **U74LVC2G86** is a dual 2-input exclusive-OR gate which provides the function $Y=A \oplus B$ or $Y=\overline{AB}+\overline{A\overline{B}}$.

This device has power-down protective circuit, preventing device destruction when it is powered down.

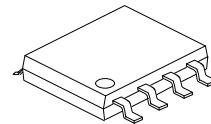

SOP-8

FEATURES

- * Operate from 1.65V to 5.5V
- * Inputs accept voltages to 5.5V
- * I_{off} supports partial-power-down mode
- * Low power dissipation, $I_{CC}=10\mu A$ (Max)
- * Max t_{PD} of 4.7 ns at 3.3V
- * $\pm 24mA$ output drive($V_{CC}=3.3V$)

ORDERING INFORMATION

Ordering Number		Package	Packing
Lead Free	Halogen Free		
U74LVC2G86L-S08-R	U74LVC2G86G-S08-R	SOP-8	Tape Reel

<p>U74LVC2G86G-S08-R</p> <p>(1) Packing Type</p> <p>(2) Package Type</p> <p>(3) Green Package</p>	<p>(1) R: Tape Reel</p> <p>(2) S08: SOP-8</p> <p>(3) G: Halogen Free and Lead Free, L: Lead Free</p>
---	--

MARKING

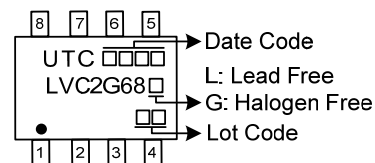

■ PIN CONFIGURATION

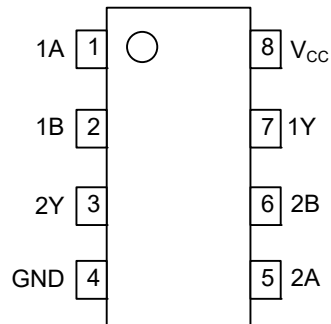

■ FUNCTION TABLE

INPUT		OUTPUT
A	B	Y
L	L	L
L	H	H
H	L	H
H	H	L

Note: H: HIGH voltage level; L: LOW voltage level

■ LOGIC DIAGRAM (positive logic)

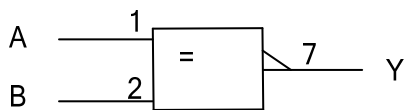
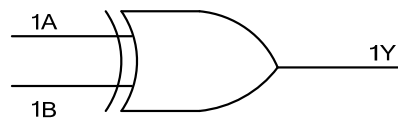
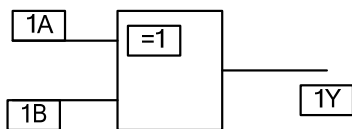

IEC logic symbol

■ ABSOLUTE MAXIMUM RATING (Unless otherwise specified)

PARAMETER	SYMBOL	RATINGS	UNIT
Supply Voltage	V_{CC}	-0.5 ~ +6.5	V
Input Voltage	V_{IN}	-0.5 ~ +6.5	V
Output Voltage	Output in the high or low state	-0.5 ~ $V_{CC}+0.5$	V
	Output in the high-impedance or power-off state	-0.5 ~ +6.5	V
V_{CC} or GND Current	I_{CC}	±100	mA
Continuous Output Current ($V_{OUT}=0$ to V_{CC})	I_{OUT}	±50	mA
Input Clamp Current ($V_{IN}<0$)	I_{IK}	-50	mA
Output Clamp Current ($V_{OUT}<0$)	I_{OK}	-50	mA
Storage Temperature Range	T_{STG}	-65 ~ +150	°C

Note: Absolute maximum ratings are those values beyond which the device could be permanently damaged.
 Absolute maximum ratings are stress ratings only and functional device operation is not implied.

■ RECOMMENDED OPERATING CONDITIONS (Unless otherwise specified)

PARAMETER	SYMBOL	TEST CONDITIONS	MIN	TYP	MAX	UNIT
Supply Voltage	V_{CC}	Operating	1.65		5.5	V
		Data retention only	1.5			V
Input Voltage	V_{IN}		0		5.5	V
Output Voltage	V_{OUT}	High or low state	0		V_{CC}	V
Input Transition Rise or Fall Rate	$\Delta t/\Delta v$	$V_{CC}=1.8V\pm 0.15V, 2.5V\pm 0.2V$			20	ns/V
		$V_{CC}=3.3V\pm 0.3V$			10	ns/V
		$V_{CC}=5V\pm 0.5V$			5	ns/V
Operating Temperature	T_A		-40		+125	°C

■ ELECTRICAL CHARACTERISTICS (Unless otherwise specified)

PARAMETER	SYMBOL	TEST CONDITIONS	MIN	TYP	MAX	UNIT
High-level Input Voltage	V_{IH}	$V_{CC}=1.65V \sim 1.95V$	$0.65 \times V_{CC}$			V
		$V_{CC}=2.3V \sim 2.7V$	1.7			V
		$V_{CC}=3V \sim 3.6V$	2			V
		$V_{CC}=4.5V \sim 5.5V$	$0.7 \times V_{CC}$			V
Low-level Input Voltage	V_{IL}	$V_{CC}=1.65V \sim 1.95V$			$0.35 \times V_{CC}$	V
		$V_{CC}=2.3V \sim 2.7V$			0.7	V
		$V_{CC}=3V \sim 3.6V$			0.8	V
		$V_{CC}=4.5V \sim 5.5V$			$0.3 \times V_{CC}$	V
High-Level Output Voltage	V_{OH}	$V_{CC}=1.65 \sim 5.5V, I_{OH}=-100\mu A$	$V_{CC}-0.1$			V
		$V_{CC}=1.65V, I_{OH}=-4mA$	1.2			V
		$V_{CC}=2.3V, I_{OH}=-8mA$	1.9			V
		$V_{CC}=3.0V, I_{OH}=-16mA$	2.4			V
		$V_{CC}=3.0V, I_{OH}=-24mA$	2.3			V
		$V_{CC}=4.5V, I_{OH}=-32mA$	3.8			V
Low-Level Output Voltage	V_{OL}	$V_{CC}=1.65 \sim 5.5V, I_{OL}=100\mu A$			0.1	V
		$V_{CC}=1.65V, I_{OL}=4mA$			0.45	V
		$V_{CC}=2.3V, I_{OL}=8mA$			0.3	V
		$V_{CC}=3.0V, I_{OL}=16mA$			0.4	V
		$V_{CC}=3.0V, I_{OL}=24mA$			0.55	V
		$V_{CC}=4.5V, I_{OL}=32mA$			0.55	V
Input Leakage Current	$I_{I(LEAK)}$	$V_{IN}=5.5V$ or GND, $V_{CC}=0 \sim 5.5V$			±5	μA
Power OFF Leakage Current	I_{off}	V_{IN} or $V_{OUT}=5.5V, V_{CC}=0V$			±10	μA

■ ELECTRICAL CHARACTERISTICS (Cont.)

PARAMETER	SYMBOL	TEST CONDITIONS	MIN	TYP	MAX	UNIT
Quiescent Supply Current	I_{CC}	$V_{IN}=5.5V$ or GND, $I_{OUT}=0$ $V_{CC}=1.65 \sim 5.5V$			10	μA
Additional Quiescent Supply Current Per Input Pin	ΔI_{CC}	$V_{CC}=3 \sim 5.5V$, One input at $V_{CC}-0.6V$, Other inputs at V_{CC} or GND			500	μA
Input Capacitance	C_I	$V_{CC}=3.3V$, $V_{IN}=V_{CC}$ or GND		5		pF

■ SWITCHING CHARACTERISTICS (Unless otherwise specified)

PARAMETER	SYMBOL	TEST CONDITIONS	MIN	TYP	MAX	UNIT
Propagation delay from input (A or B) to output(Y)	t_{PLH}/t_{PHL}	$V_{CC}=1.8V \pm 0.15V$, $C_L=30pF$	4.1		9.9	ns
		$V_{CC}=2.5V \pm 0.2V$, $C_L=30pF$	2		5.7	ns
		$V_{CC}=3.3V \pm 0.3V$, $C_L=50pF$	1.6		4.7	ns
		$V_{CC}=5V \pm 0.5V$, $C_L=50pF$	1.4		3.6	ns

■ OPERATING CHARACTERISTICS (Unless otherwise specified)

PARAMETER	SYMBOL	TEST CONDITIONS	MIN	TYP	MAX	UNIT
Power Dissipation Capacitance	C_{PD}	$V_{CC}=3.3V$, $f=10MHz$		21		pF

■ TEST CIRCUIT AND WAVEFORMS(Cont.)

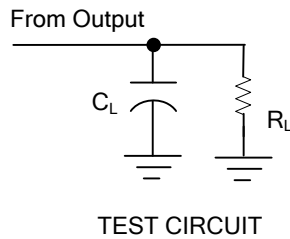

V _{CC}	Inputs		V _M	C _L	R _L
	V _{IN}	t _R , t _F			
1.8V±0.15V	V _{CC}	≤2ns	V _{CC} /2	30pF	1KΩ
2.5V±0.2V	V _{CC}	≤2ns	V _{CC} /2	30pF	500Ω
3.3V±0.3V	3V	≤2.5ns	1.5V	50pF	500Ω
5V±0.5V	V _{CC}	≤2.5ns	V _{CC} /2	50pF	500Ω

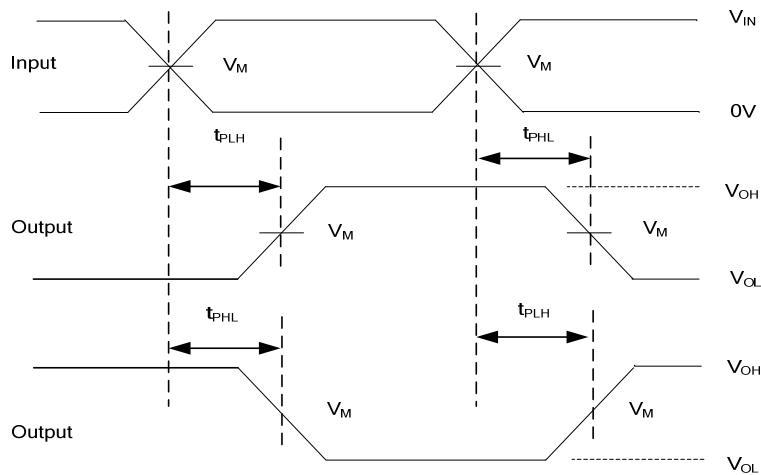

Note: C_L includes probe and jig capacitance.

All input pulses are supplied by generators having the following characteristics: PRR ≤10MHz, Z_o = 50Ω.

UTC assumes no responsibility for equipment failures that result from using products at values that exceed, even momentarily, rated values (such as maximum ratings, operating condition ranges, or other parameters) listed in products specifications of any and all UTC products described or contained herein. UTC products are not designed for use in life support appliances, devices or systems where malfunction of these products can be reasonably expected to result in personal injury. Reproduction in whole or in part is prohibited without the prior written consent of the copyright owner. UTC reserves the right to make changes to information published in this document, including without limitation specifications and product descriptions, at any time and without notice. This document supersedes and replaces all information supplied prior to the publication hereof.