



UCD4060B

CMOS IC

CMOS 14-STAGE RIPPLE-CARRY BINARY COUNTER/DIVIDER AND OSCILLATOR

■ DESCRIPTION

UCD4060B consists of an oscillator section and 14 ripple-carry binary counter stages. The oscillator configuration allows design of either R_C or crystal oscillator circuits. A RESET input is provided which resets the counter to the all-0's state and disables the oscillator. A high level on the RESET line accomplishes the reset function. All counter stages are master-slave flip-flops. The state of the counter is advanced one step in binary order on the negative transition of ΦI and ΦO . All inputs and outputs are fully buffered. Schmitt trigger action on the input-pulse line permits unlimited input-pulse rise and fall times.

■ FEATURES

- * 12MHz clock rate at 15V
- * Common reset
- * Fully static operation
- * Buffered inputs and outputs
- * Schmitt trigger input-pulse line

■ OSCILLATOR FEATURES

- * All active components on chip
- * RC or crystal oscillator configuration
- * RC oscillator frequency of 690 kHz min. at 15V

■ APPLICATIONS

- * Control counters
- * Timers
- * Frequency dividers
- * Time-delay circuits

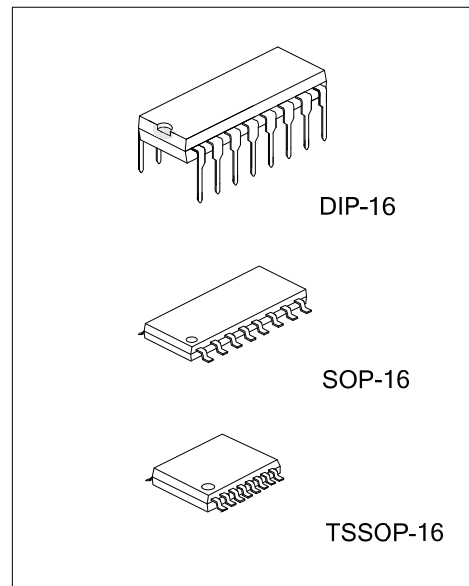

■ ORDERING INFORMATION

Ordering Number		Package	Packing
Lead Free	Halogen Free		
UCD4060BL-D16-T	UCD4060BG-D16-T	DIP-16	Tube
UCD4060BL-S16-R	UCD4060BG-S16-R	SOP-16	Tape Reel
UCD4060BL-P16-R	UCD4060BG-P16-R	TSSOP-16	Tape Reel

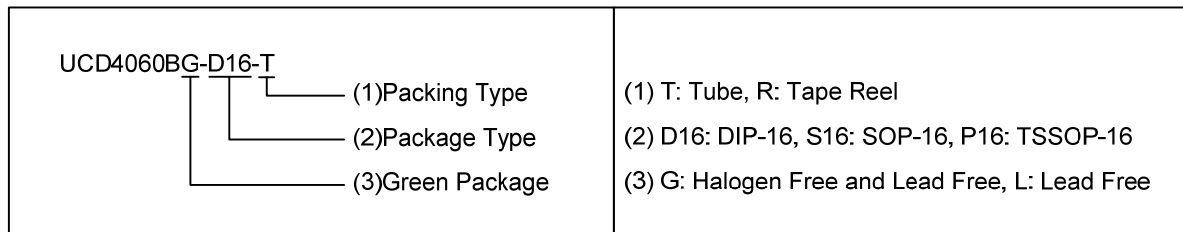

■ MARKING

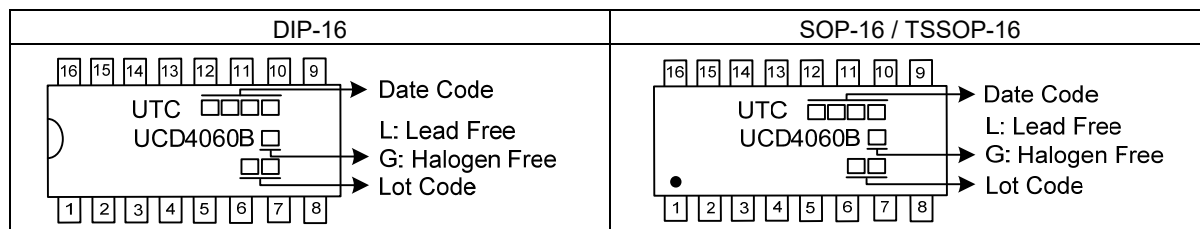

■ PIN CONFIGURATION

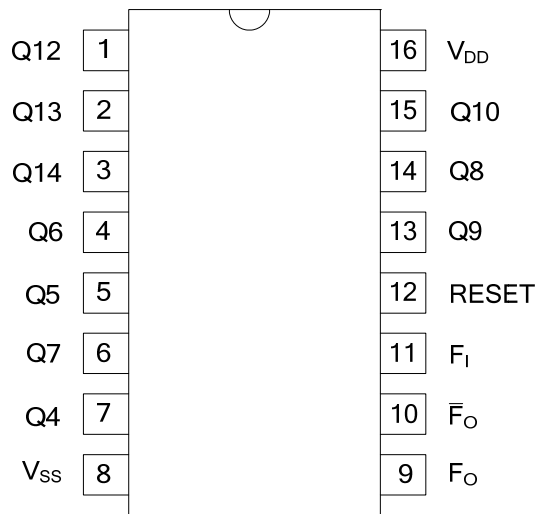

■ LOGIC DIAGRAM

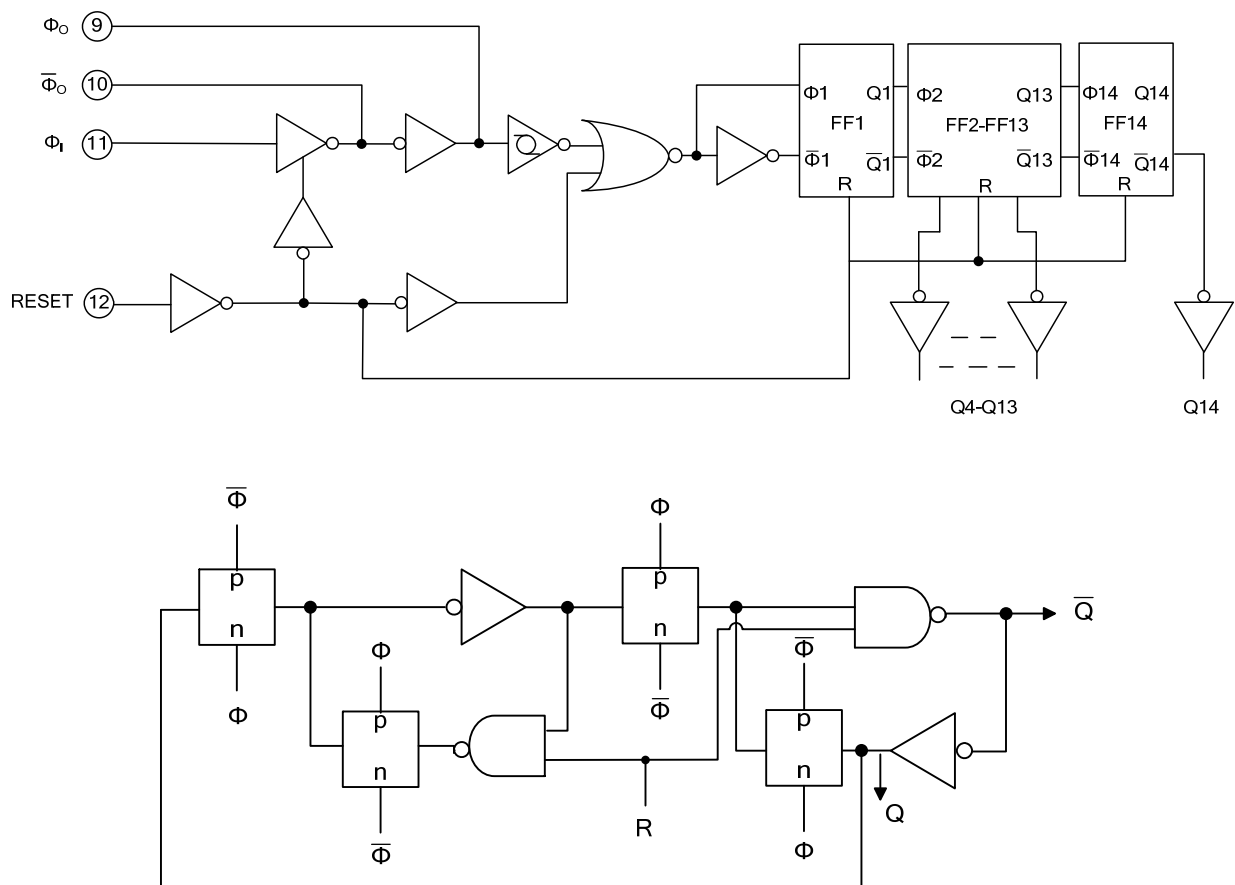

■ ABSOLUTE MAXIMUM RATING (Unless otherwise specified)

PARAMETER	SYMBOL	RATINGS	UNIT
Supply Voltage	V_{DD}	-0.5 ~ 20	V
Input Voltage	V_{IN}	-0.5 ~ $V_{CC}+0.5$	V
Output Voltage	V_{OUT}	-0.5 ~ $V_{CC}+0.5$	V
Input Clamp Current ($V_{IN}<0$, or $V_{IN}>V_{DD}$)	I_{IK}	± 10	mA
Power Dissipation ($T_A=-40^{\circ}\text{C}\sim+125^{\circ}\text{C}$)	P_D	500	mW
Storage Temperature	T_{STG}	-65 ~ +150	$^{\circ}\text{C}$

Notes: 1. Absolute maximum ratings are those values beyond which the device could be permanently damaged. Absolute maximum ratings are stress ratings only and functional device operation is not implied.
2. The input and output voltage ratings may be exceeded if the input and output current ratings are observed.

■ RECOMMENDED OPERATING CONDITIONS

PARAMETER	SYMBOL	CONDITIONS	MIN	TPY	MAX	UNIT
Supply Voltage	V_{DD}		3		18	V
Input-Pulse Width	t_w	$V_{DD}=5\text{V}$	100			ns
		$V_{DD}=10\text{V}$	40			ns
		$V_{DD}=15\text{V}$	30			ns
Input-Pulse Frequency	$f_{\phi I}$	$V_{DD}=5\text{V}$			3.5	MHz
		$V_{DD}=10\text{V}$			8	MHz
		$V_{DD}=15\text{V}$			12	MHz
Input-Pulse Rise and Fall Time	t_r / t_f	$V_{DD}=5\text{V}$	Unlimited			μs
		$V_{DD}=10\text{V}$				μs
		$V_{DD}=15\text{V}$				μs
Reset Pulse Width	t_w	$V_{DD}=5\text{V}$	120			ns
		$V_{DD}=10\text{V}$	60			ns
		$V_{DD}=15\text{V}$	40			ns
Operating Temperature	T_A		-40		+125	$^{\circ}\text{C}$

■ THERMAL DATA

PARAMETER	SYMBOL	RATINGS	UNIT	
Junction to Ambient	DIP-16	θ_{JA}	69	$^{\circ}\text{C}/\text{W}$
	SOP-16		90	$^{\circ}\text{C}/\text{W}$
	TSSOP-16		110	$^{\circ}\text{C}/\text{W}$

■ ELECTRICAL CHARACTERISTICS (Unless otherwise specified)

PARAMETER	SYMBOL	CONDITIONS	MIN	TPY	MAX	UNIT
Quiescent Supply Current	I_{CC}	$V_{IN}=0, 5V, V_{DD}=5V$		0.04	5	μA
		$V_{IN}=0, 10V, V_{DD}=10V$		0.04	10	
		$V_{IN}=0, 15V, V_{DD}=15V$		0.04	20	
		$V_{IN}=0, 20V, V_{DD}=20V$		0.08	100	
Output Low (Sink) Current	I_{OL}	$V_{OUT}=0.4V, V_{IN}=0, 5V, V_{DD}=5V$	0.51	1		mA
		$V_{OUT}=0.5V, V_{IN}=0, 10V, V_{DD}=10V$	1.3	2.6		
		$V_{OUT}=1.5V, V_{IN}=0, 15V, V_{DD}=15V$	3.4	6.8		
Output High (Source) Current	I_{OH}	$V_{OUT}=4.6V, V_{IN}=0, 5V, V_{DD}=5V$	-0.51	-1		mA
		$V_{OUT}=2.5V, V_{IN}=0, 5V, V_{DD}=5V$	-1.6	-3.2		
		$V_{OUT}=9.5V, V_{IN}=0, 10V, V_{DD}=10V$	-1.3	-2.6		
		$V_{OUT}=13.5V, V_{IN}=0, 15V, V_{DD}=15V$	-3.4	-6.8		
Output Voltage: Low-Level	V_{OL}	$V_{IN}=0, 5V, V_{DD}=5V$		0	0.05	V
		$V_{IN}=0, 10V, V_{DD}=10V$		0	0.05	
		$V_{IN}=0, 15V, V_{DD}=15V$		0	0.05	
Output Voltage: High-Level	V_{OH}	$V_{IN}=0, 5V, V_{DD}=5V$	4.95	5		V
		$V_{IN}=0, 10V, V_{DD}=10V$	9.95	10		
		$V_{IN}=0, 15V, V_{DD}=15V$	14.95	15		
Input Low Voltage	V_{IL}	$V_{OUT}=0.5, 4.5V, V_{DD}=5V$			1.5	V
		$V_{OUT}=1, 9V, V_{DD}=10V$			3	
		$V_{OUT}=1.5, 13.5V, V_{DD}=15V$			4	
Input High Voltage	V_{IH}	$V_{OUT}=0.5, 4.5V, V_{DD}=5V$	3.5			V
		$V_{OUT}=1, 9V, V_{DD}=10V$	7			
		$V_{OUT}=1.5, 13.5V, V_{DD}=15V$	11			
Input Leakage Current	$I_{I(LEAK)}$	$V_{IN}=0, 18V, V_{DD}=18V$		$\pm 10^{-5}$	± 0.1	μA

■ SWITCHING CHARACTERISTICS

(UInput $t_r / t_f=20ns, C_L=50pF, R_L=200k\Omega$, Unless otherwise specified)

PARAMETER	SYMBOL	CONDITIONS	MIN	TPY	MAX	UNIT
CLOCKED OPERATION						
Propagation Delay Time, ΦI to Q4	t_{PLH} / t_{PHL}	$V_{DD}=5V$		370	740	ns
		$V_{DD}=10V$		150	300	
		$V_{DD}=15V$		100	200	
Propagation Delay Time, Qn to Qn+1	t_{PLH} / t_{PHL}	$V_{DD}=5V$		100	200	ns
		$V_{DD}=10V$		50	100	
		$V_{DD}=15V$		40	80	
Transition Time	t_{THL} / t_{TLH}	$V_{DD}=5V$		100	200	ns
		$V_{DD}=10V$		50	100	
		$V_{DD}=15V$		40	80	
Maximum Input-Pulse Frequency	$f_{\Phi I}$	$V_{DD}=5V$	3.5	7		MHz
		$V_{DD}=10V$	8	16		
		$V_{DD}=15V$	12	24		
Minimum Input-Pulse Width	t_w	$V_{DD}=5V$		50	100	ns
		$V_{DD}=10V$		20	40	
		$V_{DD}=15V$		15	30	
Input-Pulse Rise and Fall Time	$t_r \Phi / t_f \Phi$	$V_{DD}=5V$	Unlimited			
		$V_{DD}=10V$				
		$V_{DD}=15V$				
Average Input Capacitance	C_I	Any Input		5	7.5	pF

■ SWITCHING CHARACTERISTICS (Cont.)

PARAMETER	SYMBOL	CONDITIONS	MIN	TPY	MAX	UNIT	
RESET OPERATION							
Propagation Delay Time	t_{PLH} / t_{PHL}	$V_{DD}=5V$		180	360	ns	
		$V_{DD}=10V$		80	160	ns	
		$V_{DD}=15V$		50	100	ns	
Minimum Reset Pulse Width	t_{WR}	$V_{DD}=5V$		60	120	ns	
		$V_{DD}=10V$		30	60	ns	
		$V_{DD}=15V$		20	40	ns	
RC OPERATION							
Variation of Frequency		$C_X=200pF,$ $R_S=560k\Omega,$ $R_X=50k\Omega$	$V_{DD}=5V$		23±10%		kHz
			$V_{DD}=10V$		24±10%		kHz
			$V_{DD}=15V$		25±10%		kHz
Variation of Frequency with voltage change		$C_X=200pF,$ $R_S=560k\Omega,$ $R_X=50k\Omega$	$V_{DD}=5V\sim 10V$		1.5		kHz
			$V_{DD}=10V\sim 15V$		0.5		kHz
R_X max			$C_X=10mF, V_{DD}=5V$			20	MΩ
			$C_X=50\mu F, V_{DD}=10V$			20	MΩ
			$C_X=10\mu F, V_{DD}=15V$			10	MΩ
C_X max			$R_X=500k\Omega, V_{DD}=5V$			1000	μF
			$R_X=300k\Omega, V_{DD}=10V$			50	
			$R_X=300k\Omega, V_{DD}=15V$			50	
Maximum Oscillator Frequency		$C_X=15pF,$ $R_S=30k\Omega,$ $R_X=5k\Omega$	$V_{DD}=10V$	530	650	810	kHz
			$V_{DD}=15V$	690	800	940	kHz
Drive Current at Pin 9	I_{OL}		$V_O=0.4V, V_{DD}=5V$	0.16	0.35		mA
			$V_O=0.5V, V_{DD}=10V$	0.42	0.8		mA
			$V_O=1.5V, V_{DD}=15V$	1	2		mA
	I_{OH}		$V_O=4.6V, V_{DD}=5V$	-0.16	-0.35		mA
			$V_O=9.5V, V_{DD}=10V$	-0.42	-0.8		mA
			$V_O=13.5V, V_{DD}=15V$	-1	-2		mA

■ TEST CIRCUIT AND WAVEFORMS

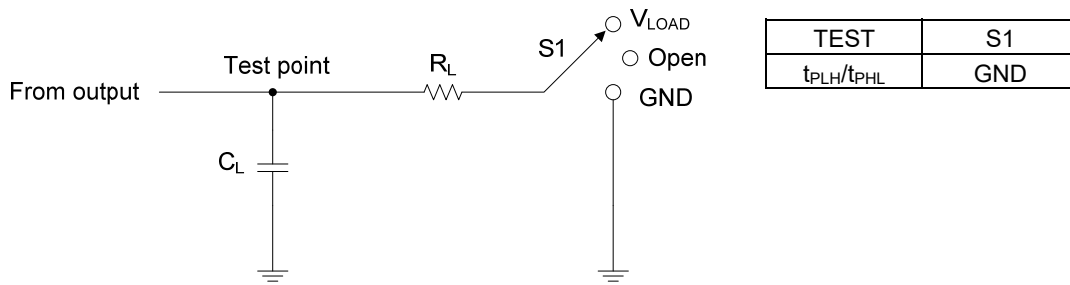

Fig. 1 Test Circuit

Inputs		V_M	V_{LOAD}	C_L	R_L
V_{IN}	t_r, t_f				
V_{CC}	20 ns	$V_{CC}/2$	V_{CC}	50 pF	200 K Ω

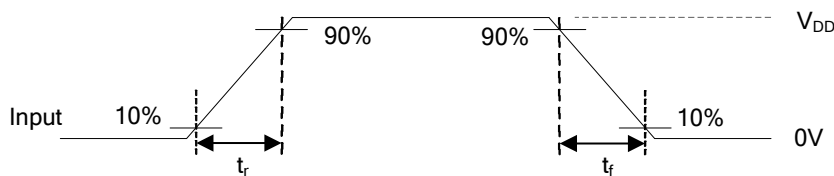

Fig. 2 Voltage Waveforms Input Rise And Fall Times

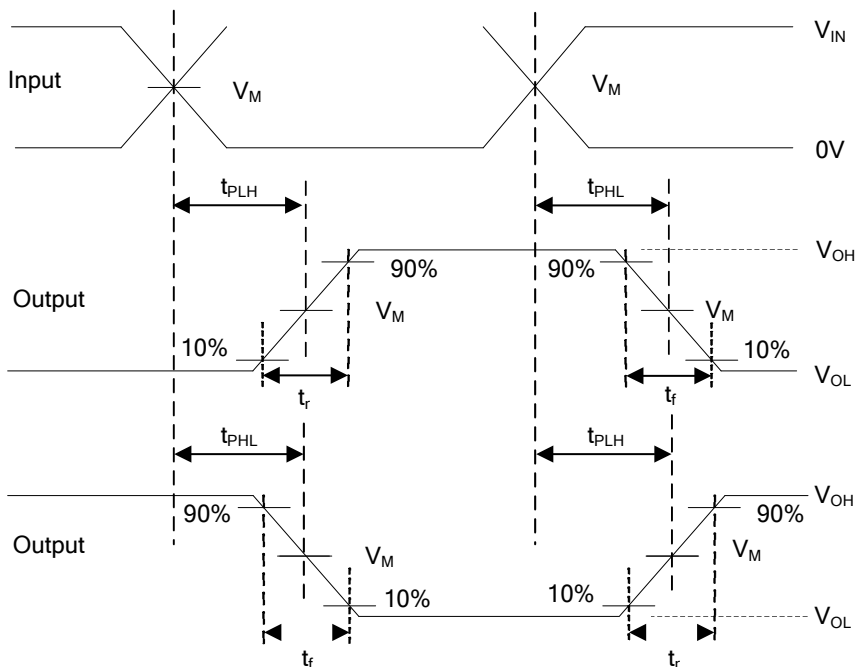

Fig. 3 Voltage Waveforms Propagation Delay And Output Transition Times

- Notes: 1. C_L includes probe and jig capacitance.
- 2. All input pulses are supplied by generators having the following characteristics: PRR \leq 1MHz, $Z_O = 50\Omega$.

■ TEST CIRCUIT AND WAVEFORMS (Cont.)

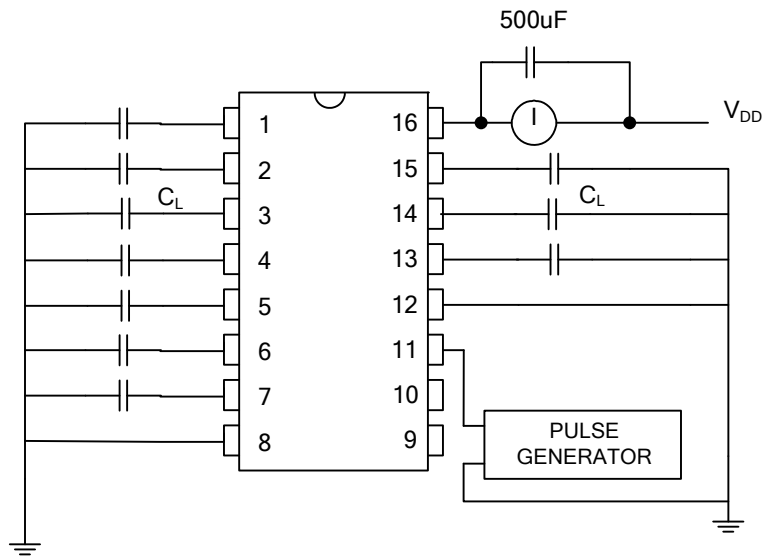

Fig. 4 Dynamic Power Dissipation Test Circuit

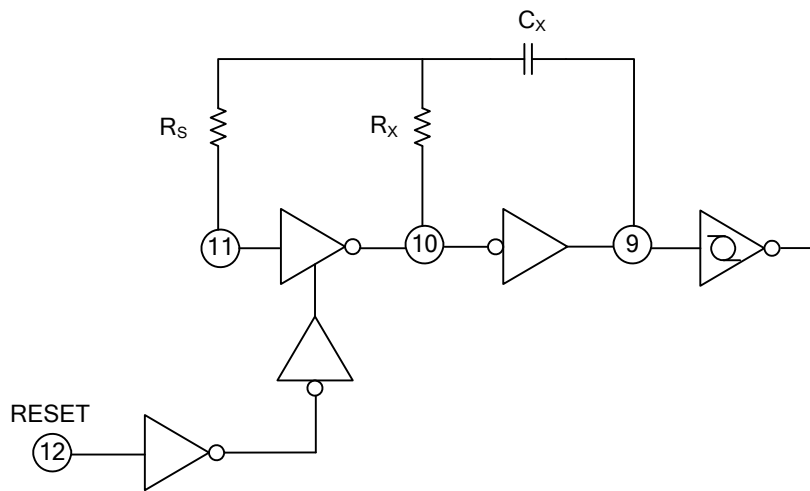

Fig. 5 Typical RC Circuit

■ TEST CIRCUIT AND WAVEFORMS (Cont.)

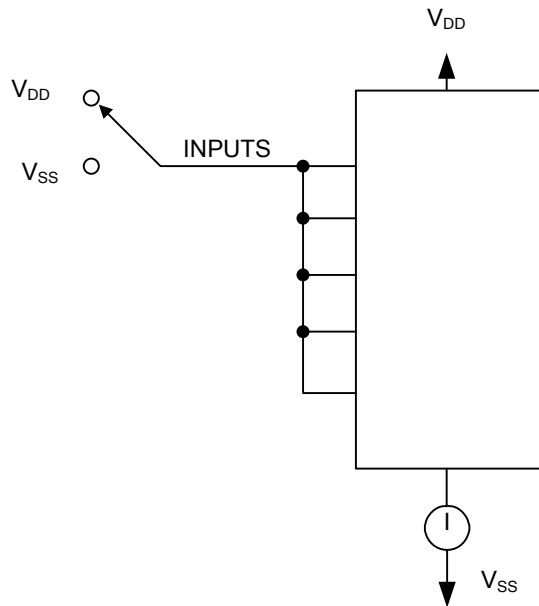

Fig. 6 Quiescent device current test circuit

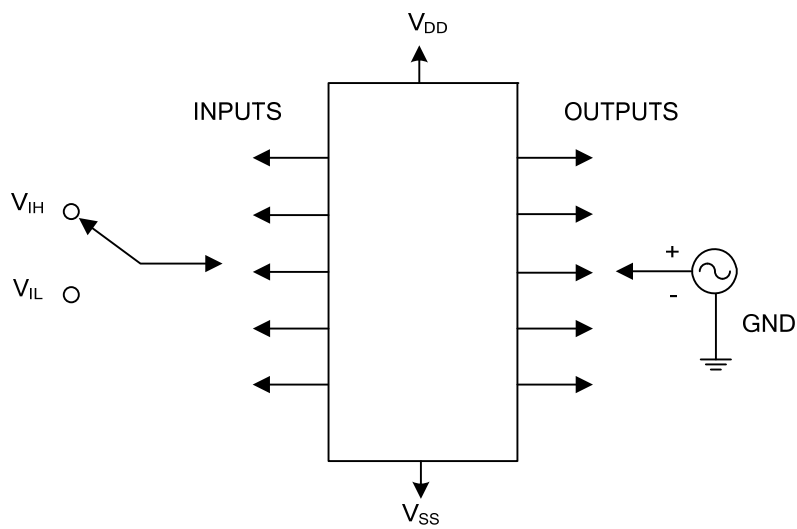
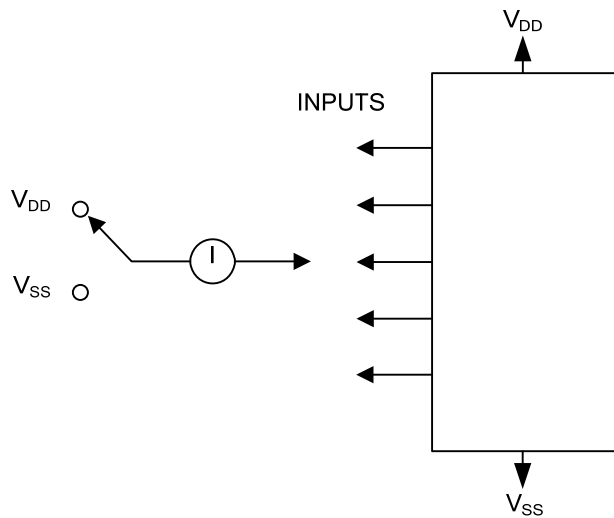

Fig. 7 Input voltage test circuit

■ TEST CIRCUIT AND WAVEFORMS (Cont.)

**Fig. 8 Input current test circuit**

Note: Measure inputs sequentially, to both V_{DD} and V_{SS} ; Connect all unused inputs to either V_{DD} or V_{SS} .

UTC assumes no responsibility for equipment failures that result from using products at values that exceed, even momentarily, rated values (such as maximum ratings, operating condition ranges, or other parameters) listed in products specifications of any and all UTC products described or contained herein. UTC products are not designed for use in life support appliances, devices or systems where malfunction of these products can be reasonably expected to result in personal injury. Reproduction in whole or in part is prohibited without the prior written consent of the copyright owner. UTC reserves the right to make changes to information published in this document, including without limitation specifications and product descriptions, at any time and without notice. This document supersedes and replaces all information supplied prior to the publication hereof.