



# BTB12

**TRIAC**

## 12A TRIACS

### DESCRIPTION

The UTC **BTB12** is a 12A triacs which can be operated in 4 quadrants, it uses UTC's advanced technology to provide customers with high commutation performances.

The UTC **BTB12** is suitable for AC switching application and phase control application such as fan speed and temperature modulation control, lighting control and static switching relay, either in through-hole or surface-mount packages.

### SYMBOL

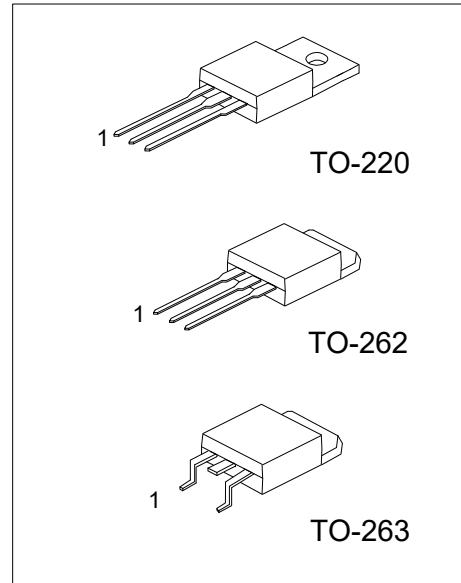
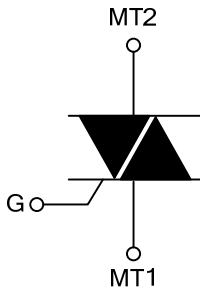

### ORDERING INFORMATION

Ordering Number		Package	Pin Assignment			Packing
Lead Free	Halogen Free		1	2	3	
BTB12L-x-x-TA3-T	BTB12G-x-x-TA3-T	TO-220	MT1	MT2	G	Tube
BTB12L-x-x-T2Q-T	BTB12G-x-x-T2Q-T	TO-262	MT1	MT2	G	Tube
BTB12L-x-x-TQ2-T	BTB12G-x-x-TQ2-T	TO-263	MT1	MT2	G	Tube
BTB12L-x-x-TQ2-R	BTB12G-x-x-TQ2-R	TO-263	MT1	MT2	G	Tape Reel

Note: Pin Assignment: MT1: MT1 MT2: MT2 G: Gate

<p>BTB12G-x-x-TA3-T</p> <p>(1) Packing Type                  (2) Package Type                  (3) Sensitivity and type                  (4) Voltage                  (5) Green Package</p>	<p>(1) T: Tube, R: Tape Reel                  (2) TA3: TO-220, T2Q: TO-262, TQ2: TO-263                  (3) refer to SENSITIVITY AND TYPE                  (4) 6: 600V, 8: 800V                  (5) G: Halogen Free and Lead Free, L: Lead Free</p>
---	---

### SENSITIVITY AND TYPE

PART NUMBER	VOLTAGE		SENSITIVITY	TYPE
	600V	800V		
B	⊙	⊙	50mA	STANDARD
C	⊙	⊙	25mA	STANDARD

⊙: Available

## MARKING

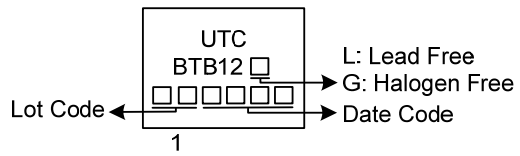

## ■ ABSOLUTE MAXIMUM RATINGS

PARAMETER			SYMBOL	RATINGS	UNIT
RMS On-State Current (Full Sine Wave)		$T_C=90^\circ\text{C}$	$I_{T(RMS)}$	12	A
Non Repetitive Surge Peak On-State Current (Full Cycle, $T_J$ initial= $25^\circ\text{C}$ )	F=50 Hz	t=20ms	$I_{TSM}$	120	A
	F=60 Hz	t=16.7ms		126	A
I <sup>2</sup> t Value for Fusing		$t_p=10\text{ms}$	I <sup>2</sup> t	78	A <sup>2</sup> s
Critical Rate of Rise of On-State Current $I_G=2xI_{GT}$ , $t_r \leq 100\text{ns}$		F=120 Hz $T_J=125^\circ\text{C}$	di/dt	50	A/ $\mu\text{s}$
Non Repetitive Surge Peak Off-State Voltage		$t_p=10\text{ms}$ $T_J=25^\circ\text{C}$	$V_{DSM}/V_{RSM}$	$V_{DRM}/V_{RRM}+100$	V
Peak Gate Current		$t_p=20\mu\text{s}$ $T_J=125^\circ\text{C}$	$I_{GM}$	4	A
Average Gate Power Dissipation		$T_J=125^\circ\text{C}$	$P_{G(AV)}$	1	W
Operating Junction Temperature			$T_J$	-40 ~ +125	$^\circ\text{C}$
Storage Junction Temperature			$T_{STG}$	-40 ~ +150	$^\circ\text{C}$

Note: Absolute maximum ratings are those values beyond which the device could be permanently damaged. Absolute maximum ratings are stress ratings only and functional device operation is not implied.

## ■ THERMAL DATA

PARAMETER	SYMBOL	RATINGS	UNIT
Junction to Ambient	$\theta_{JA}$	60	$^\circ\text{C}/\text{W}$
Junction to Case (AC)	$\theta_{JC}$	1.4	$^\circ\text{C}/\text{W}$

## ■ ELECTRICAL CHARACTERISTICS ( $T_J=25^\circ\text{C}$ unless otherwise specified)

### FOR STANDARD TYPE (4 QUADRANTS)

PARAMETER	SYMBOL	TEST CONDITIONS	C			B			UNIT	
			MIN	TYP	MAX	MIN	TYP	MAX		
Gate Trigger Current (Note 1)	$I_{GT}$	$V_D=12\text{V}$ , $R_L=33\Omega$	I-II-III			25			50	mA
			IV			50			100	mA
Gate Trigger Voltage	$V_{GT}$		ALL			1.3			1.3	V
Gate Non-Trigger Voltage	$V_{GD}$	$V_D=V_{DRM}$ , $R_L=3.3\text{k}\Omega$ , $T_J=125^\circ\text{C}$	ALL	0.2			0.2			V
Holding Current (Note 2)	$I_H$	$I_T=500\text{mA}$				25			50	mA
Latching Current	$I_L$	$I_G=1.2 I_{GT}$	I-III-IV			40			50	mA
			II			80			100	mA
Critical Rate of Rise of Off-State Voltage (Note 2)	dV/dt	$V_D=67\%V_{DRM}$ , Gate Open, $T_J=125^\circ\text{C}$		200			400			V/ $\mu\text{s}$
Critical Rate of Rise of Off-State Voltage at Commutation (Note 2)	(dV/dt) <sub>c</sub>	(di/dt) <sub>c</sub> =5.3A/ms, $T_J=125^\circ\text{C}$		5			10			V/ $\mu\text{s}$

## ■ STATIC CHARACTERISTICS

PARAMETER	SYMBOL	TEST CONDITIONS	MIN	TYP	MAX	UNIT
Peak On-State Voltage (Note)	$V_T$	$I_{TM}=17\text{A}$ , $t_p=380\mu\text{s}$		$T_J=25^\circ\text{C}$		1.55 V
Threshold Voltage (Note)	$V_{TO}$			$T_J=125^\circ\text{C}$		0.85 V
Dynamic Resistance (Note)	$R_D$			$T_J=125^\circ\text{C}$		35 m $\Omega$
Repetitive Peak Off-State Current	$I_{DRM}$	$V_{DRM}$ Rated		$T_J=25^\circ\text{C}$		5 $\mu\text{A}$
	$I_{RRM}$	$V_{RRM}$ Rated		$T_J=125^\circ\text{C}$		1 mA

Notes: 1. Minimum  $I_{GT}$  is guaranteed at 5% of  $I_{GT}$  max.  
2. For both polarities of MT2 referenced to MT1.

UTC assumes no responsibility for equipment failures that result from using products at values that exceed, even momentarily, rated values (such as maximum ratings, operating condition ranges, or other parameters) listed in products specifications of any and all UTC products described or contained herein. UTC products are not designed for use in life support appliances, devices or systems where malfunction of these products can be reasonably expected to result in personal injury. Reproduction in whole or in part is prohibited without the prior written consent of the copyright owner. UTC reserves the right to make changes to information published in this document, including without limitation specifications and product descriptions, at any time and without notice. This document supersedes and replaces all information supplied prior to the publication hereof.